

# RADIO — ELECTRONICS

K

Exclusive  
**TELEVISION  
NEWS**

Section

HUGO GERNSBACH, Editor

formerly

**RADIO  
CRAFT**

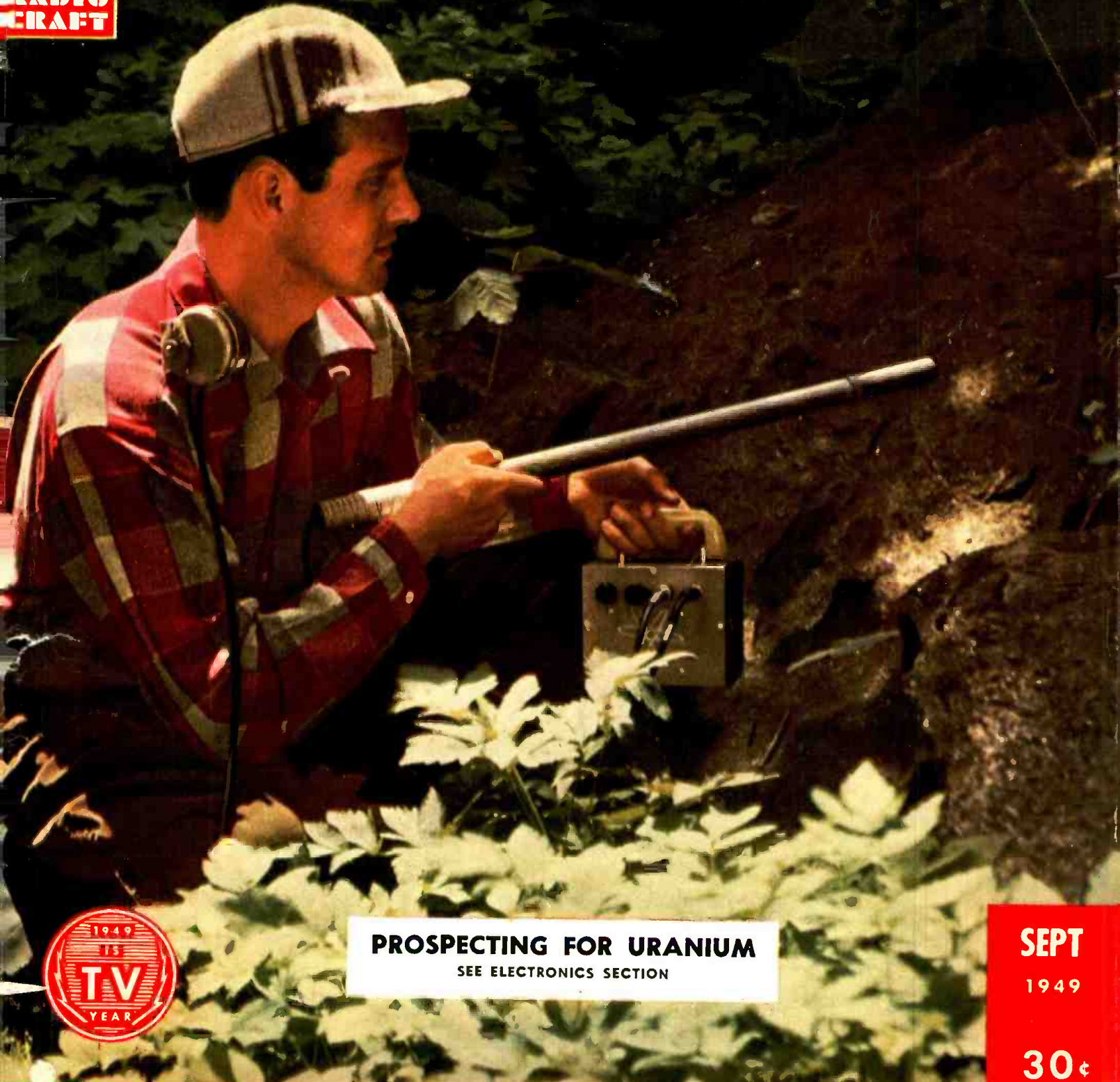

**PROSPECTING FOR URANIUM**  
SEE ELECTRONICS SECTION



**SEPT**  
1949

**30¢**

U. S. and  
CANADA

**LATEST IN RADIO — ELECTRONICS — TELEVISION**

[www.americanradiohistory.com](http://www.americanradiohistory.com)



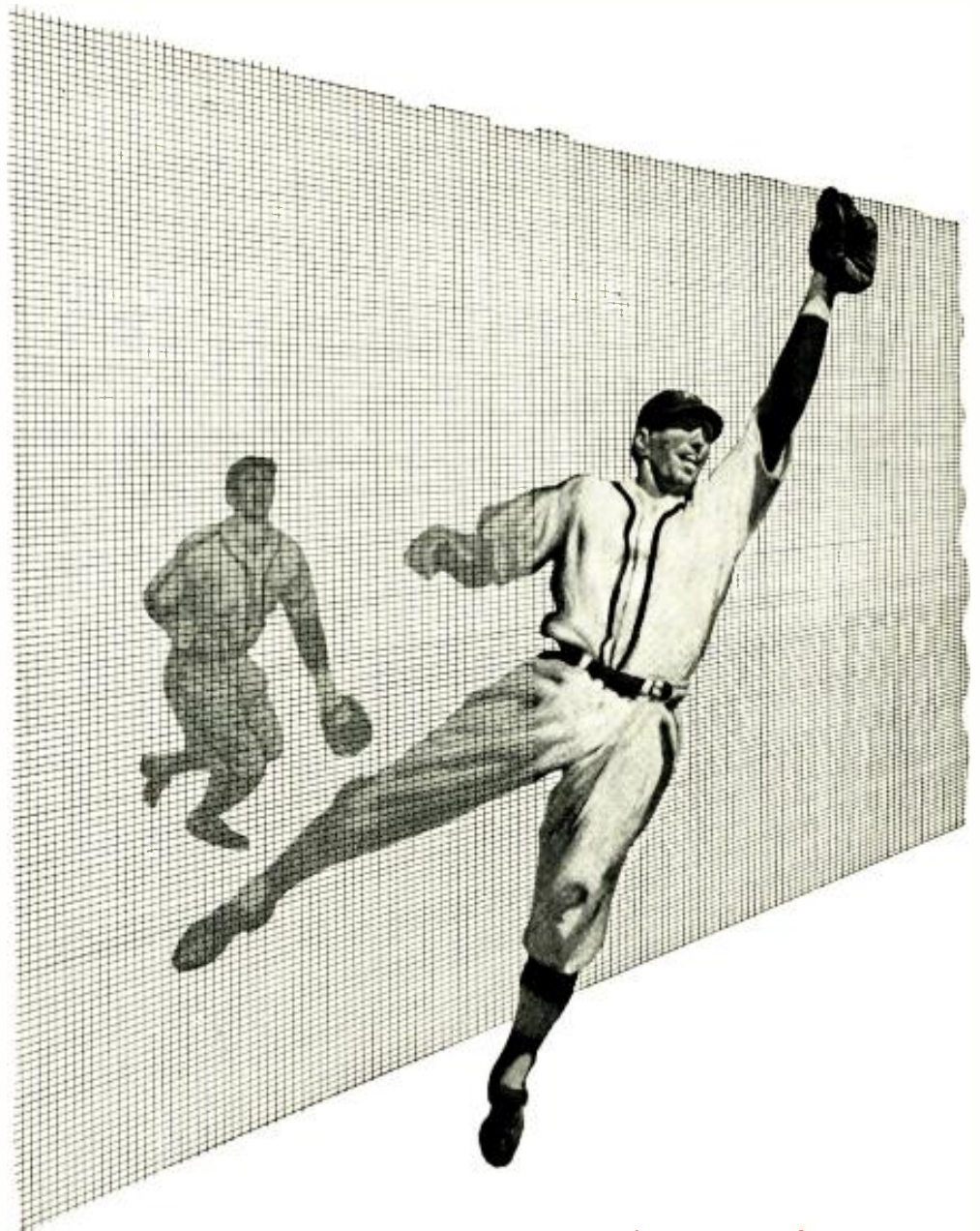

RCA Laboratories developed a copper mesh with 2,250,000 tiny openings to the square inch for the television camera "eye."

*You get **finer television pictures** through this super-fine mesh*

In RCA Image Orthicon television cameras you will find a super-fine copper mesh. Until a new technique for making such screen was discovered at RCA Laboratories, only coarse and irregular mesh—which obstructed 60% of the picture—was available.

Today, through RCA research, such mesh can be made with 1500 gossamer wires to the linear inch.

An ordinary pinhead will cover about 7000 of its tiny openings.

By RCA's technique—now producing commercial quantities of 200- and 500-mesh screens—the mesh is so fine, so regular in structure, that it is invisible on home television receivers . . . and as much as 85% more television picture passes through.

**You benefit—many times**

This new type of super-fine wire mesh, and the technique for making

it, like most major developments in all-electronic television, is another RCA Laboratories *first*. Leadership in science and engineering adds *value beyond price* to any product or service of RCA and RCA Victor.

\* \* \*

*The newest developments in radio, television, and electronics may be seen in action at RCA Exhibition Hall, 36 West 49th Street, N. Y. Admission is free, and you are cordially invited. Radio Corporation of America, Radio City, N. Y. 20.*



**RADIO CORPORATION of AMERICA**

*World Leader in Radio — First in Television*



# LEARN RADIO-TELEVISION

BY PRACTICING AT HOME  
IN SPARE TIME WITH  
THESE AND OTHER KITS  
I SEND YOU

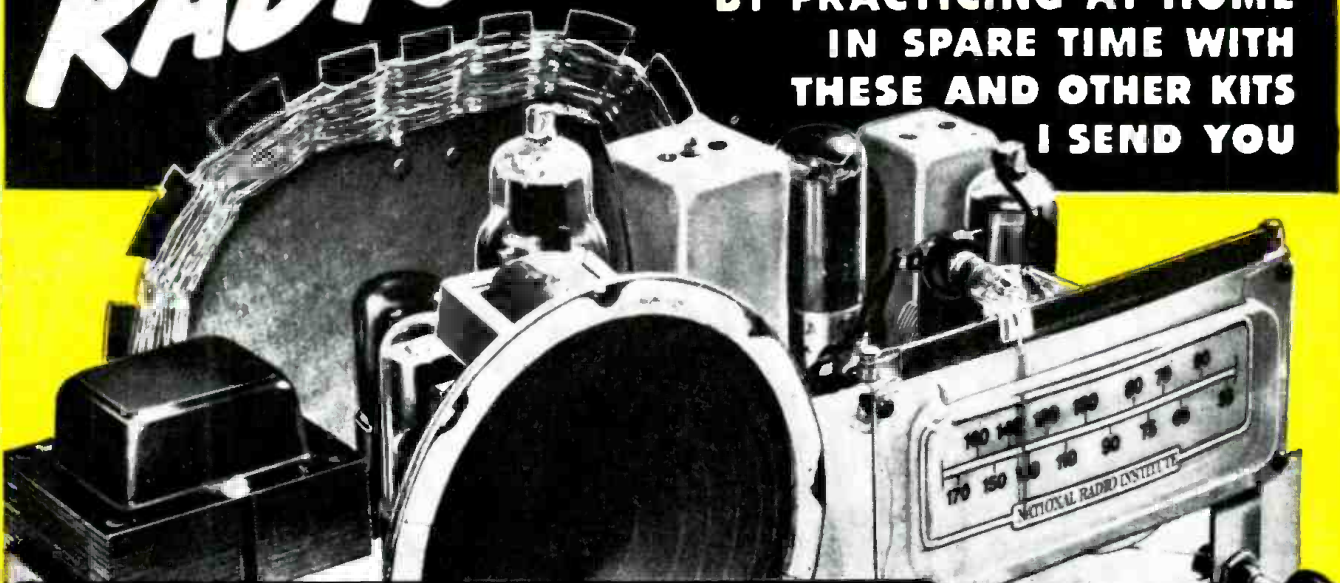

**I WILL TRAIN YOU AT HOME FOR  
GOOD PAY-SUCCESS  
A BRIGHT FUTURE**  
*in America's Fastest-Growing Industry*



J. E. SMITH, President  
National Radio Institute

### I TRAINED THESE MEN

"N. R. I. helped qualify me for position as Radio Mechanic with United Airlines. Have my Radiotelephone 2nd Class License."—L. M. Hauger, San Bruno, Calif.

"Work only spare time at Radio and average about \$40 a month. Knew nothing about Radio before enrolling with N. R. I."—Samuel T. DeWald, St. Clair, Pa.

"I am operating a Radio Sales and Service business. With FM and Television in the offing, we have a very profitable future."—Albert Patrick, Tampa, Florida.

Want a good-pay job in the fast growing RADIO-TELEVISION Industry? Want a money-making Radio-Television shop of your own? Here's your opportunity. I've trained hundreds of men to be successful Technicians. MEN WITH NO PREVIOUS EXPERIENCE. My tested and proved train-at-home method makes learning easy. You learn Radio-Television principles from illustrated lessons. You get practical experience building, experimenting with MANY KITS OF PARTS I send. All equipment yours to keep.

### MAKE EXTRA MONEY IN SPARE TIME

The day you enroll, I start sending SPECIAL BOOKLETS that show you how to make \$5, \$10 a week or more EXTRA MONEY fixing neighbors' Radios in spare time while learning. From here, it's a short step to your own shop or a good-pay Radio-Television servicing job. Or be a licensed Radio-Television Operator or Technician. The number of Radio Stations has nearly tripled in the last few years—and within three years, experts predict there will be 1000 Television stations on the air. Then add developments in FM, Two Way Radio, Police, Marine, Aviation, Microwave Relay Radio! Think what this means! New jobs, more jobs, good pay for qualified

men. The man who prepares now will reap rich rewards;

### MAIL COUPON FOR BOOKS FREE

Act now! Send for my FREE DOUBLE OFFER. Coupon entitles you to actual lesson, "GETTING ACQUAINTED WITH RECEIVER SERVICING." It shows you that learning at home is easy, practical. You also get my 64-page book, "HOW TO BE A SUCCESS IN RADIO-TELEVISION." It tells what my graduates are doing and earning, how quickly you can be on your way to good pay, success, a bright future. Send coupon in envelope or paste on penny postal. J. E. SMITH, President,

Dept. 9JX,  
National Radio  
Institute, Pioneer  
Home Study Radio  
School, Washington 9, D. C.

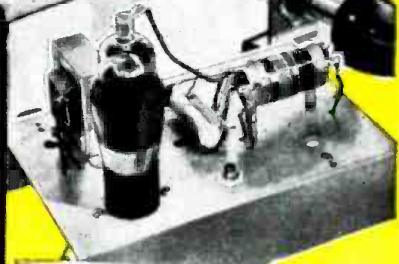

GETTING ACQUAINTED WITH  
RECEIVER SERVICING

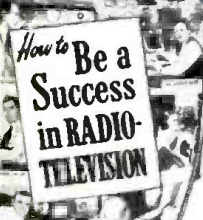

## Good for Both—FREE

MR. J. E. SMITH, President, Dept. 9JX  
National Radio Institute, Washington 9, D. C.

Mail me Sample Lesson and 64-page Book about How to Win Success in Radio-Television—both FREE. (No Salesman will call. Please write plainly.)

Name..... Age.....

Address.....

City..... Zone..... State.....

Check if Veteran Approved under G. I. Bill

**VETERANS** GET THIS TRAINING  
WITHOUT COST  
UNDER G. I. BILL

# RADIO — ELECTRONICS

formerly RADIO-CRAFT

Incorporating  
**SHORT WAVE CRAFT • TELEVISION NEWS •**  
**RADIO & TELEVISION**  
 \*Trademark registered U. S. Patent Office

Sales Managers  
**Jahn J. Lamson, Lee Robinson**  
 Circulation Manager  
**G. Aliquo**

Hugo Gernsback, Editor-in-Chief  
 Fred Shunaman, Managing Editor  
 M. Harvey Gernsback, Consulting Editor  
 Robert F. Scott, W2PWG, Technical Editor  
 R. H. Dorf, W2QMI, Associate Editor  
 I. Queen, W2OUX, Editorial Associate  
 Angie Pascale, Production Manager  
 Wm. Lyon McLaughlin,  
 Tech. Illustration Director

**Contents** ————— **September, 1949**

<b>Editorial (Page 19)</b>	
How to Get Into Radio.....	by Hugo Gernsback 19
<b>Electronics (Pages 20-29)</b>	
Prospecting for Uranium (Cover Feature).....	by Robert F. Scott 20
Information for Prospectors.....	21
The Geiger Counter—How Does it Work?.....	by Eric Leslie 22
Build this Geiger Counter.....	by Fred Shunaman and Carl Kiehl 24
Twelve New Vacuum Tubes Introduced.....	27
Electronics in Medicine, Part XI. Ultrasonic Waves Destroy Bacteria and Help Cancer Sufferers.....	By Eugene J. Thompson 28
<b>Television News (Pages 30-35)</b>	
Intercorrier Televisers Use Common I. F. Channels.....	by Jesse Dilson 30
Television Transcriptions.....	by Ricardo Muniz 32
The Transpole Variotenna, Part II.....	by Hugo Gernsback 34
<b>Broadcasting and Communications (Pages 36-37)</b>	
Citizen's Band Opened to Public for Regular Use.....	by Julian P. Freret 36
<b>Theory and Engineering (Pages 38-39)</b>	
Microwaves, Part V.....	by C. W. Palmer 38
<b>New Design (Pages 40-42)</b>	
Point Your Own Circuits.....	by Robert F. Bradley 40
New Tape Recorder Kit.....	42
<b>Servicing (Pages 43-50)</b>	
Fundamentals of Radio Servicing, Part VII, Resonant Circuits.....	by John T. Frye 43
Industrial Radio Service.....	45
Radio Set and Service Review (Zenith Model 7H918).....	46
<b>Amateur (Pages 50-54)</b>	
Operation on 160 Meters.....	by Rufus P. Turner, K6AI 50
<b>Foreign News (Pages 56-58)</b>	
European Report.....	by Ralph W. Hallows 56
<b>Departments</b>	
The Radio Month.....	8
Radio Business.....	10
Radio Electronic Circuits.....	60
New Devices.....	62
Question Box.....	64
New Patents.....	66
Try This One.....	68
Miscellany.....	70
Association News.....	72
People.....	73
Technotes.....	74
Communications.....	75
Book Reviews.....	77

**ON THE COVER:** Part-time prospector John Flood investigates a rock crevice for possible uranium deposits. Kodachrome by Avery Slack.

**RADIO-ELECTRONICS, September, 1949, Volume XX, No. 12.** Published monthly. Publication Office: Erie Ave., 10 G Street, Philadelphia 32, Pa. Entered as second class matter September 27, 1938, at the post office at Philadelphia, Pa., under the Act of March 3, 1879. **SUBSCRIPTION RATES:** In U. S. and Canada, in U. S. possessions, Mexico, South and Central American countries, \$3.50; \$6.00 for two years; \$8.00 for three years; elsewhere, \$4.50 a year, \$8.00 for two years, \$11.00 for three years. Allow one single copy 30c. All other foreign countries \$4.50 a year, \$8.00 for two years, \$11.00 for three years. Allow one month for change of address. When ordering a change please furnish an address stencil impression from a recent wrapper. **RADIO-CRAFT PUBLICATIONS, INC.** Hugo Gernsback, Pres.; M. Harvey Gernsback, Vice-Pres.; G. Aliquo, Sec'y. Contents Copyright, 1949, by Radio-Craft Publications, Inc. Text and illustrations must not be reproduced without permission of copyright owners.

**EDITORIAL and ADVERTISING OFFICES, 25 West Broadway, New York 7, N. Y. Tel. REctor 5-9690. BRANCH ADVERTISING OFFICES:** Chicago: 308 W. Washington Street, Telephone RAndolph 6-7363. Los Angeles: 1410 W. Harker, 1127 Wilshire Blvd., Tel. MA 6-1271. San Francisco: Ralph W. Harker, 582 Market St. Tel. GARfield 4-2481. **FOREIGN AGENTS:** Great Britain: Atlas Publishing and Distributing Co., Ltd., 18 Bride Lane, Fleet St., London E.C.4, Australia: McMillan's Agency, 179 Elizabeth Street, Melbourne. France: Brentano's, 37 Avenue de l'Opera, Paris 2e, Holland: Trilectron, Heemstedse, Dreef 124 Heemstede, Greece: International Book & News Agency, 17 Amerikis Street, Athens. So. Africa: Central News Agency, Ltd., Cor. Risak & Commissioner Sts., Johannesburg. Middle East: St. Imatzky Middle East Agency, Jaffa Road, Jerusalem. India: Susti Gupta Distributors Co., Armits Bazar, Patna. 14, Ananda Chatterjee Lane, Calcutta. Broadway News Centre, Post Bag #5557, Dadar, Bombay #14. K. L. Kannappa Modalliar, 30 General Patters Road, Mount Road, Madras 2, Pakistan: Paradise Book Stall, Opp. Royal Cinema, Preetzy St., Karachi 3.

Editorial and Executive Offices:  
 25 West Broadway New York 7, N. Y.



MEMBER  
 AUDIT BUREAU OF CIRCULATION



## OHMITE Little Devil

**INSULATED  
 COMPOSITION RESISTORS**

In critical television applications, Little Devil Resistors can be depended on for longer, trouble-free service. These tiny, rugged units give quiet performance and are ideal for sensitive RF circuits. Moreover, they are available in  $\pm 5\%$  as well as  $\pm 10\%$  tolerances—in  $\frac{1}{2}$ , 1, and 2-watt sizes; standard RMA values.



**NOISE-FREE  
 TYPE AB POTENTIOMETER**

Continued use has little effect on the resistance of this unit because the resistance material is solid-molded—not sprayed or painted on. In fact, the noise level often becomes less with use. The unit has a 2-watt rating with a good safety factor.

SEND NOW for Catalog No. 21

**OHMITE MFG. CO.**  
 4895 Flournoy St., Chicago 44



Be Right with...



RADIO-ELECTRONICS for



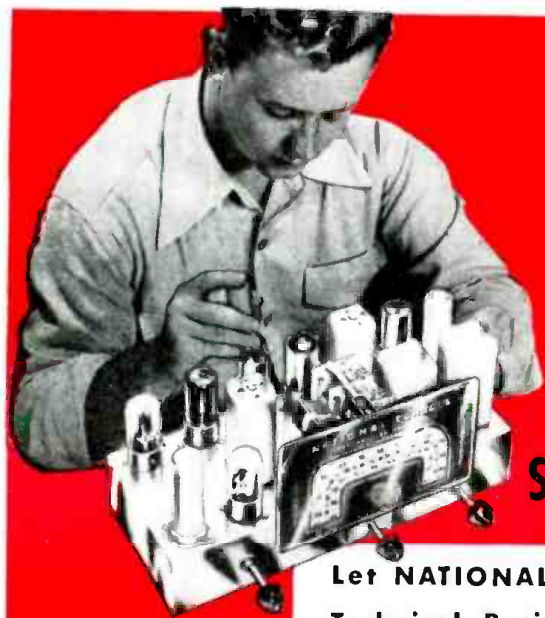

# Learn RADIO TELEVISION, ELECTRONICS *by* SHOP METHOD HOME TRAINING

Let NATIONAL SCHOOLS, of Los Angeles, a practical Technical Resident Trade School for almost 50 years, train you for today's unlimited opportunities in Radio

You receive all parts, including tubes, for building this fine, modern Superheterodyne Receiver. This and other valuable standard equipment becomes your property.

*these two FREE books will tell you how*

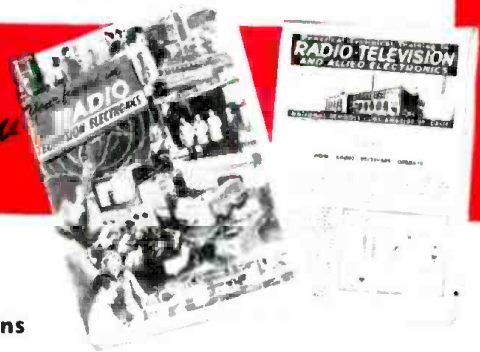

## Good Jobs Await the Trained Radio Technician

You are needed in the great, modern Radio, Television and Electronics industry! Trained Radio technicians are in constant and growing demand at excellent pay—in Broadcasting, Communications, Television, Radar, Research Laboratories, Home Radio Service, etc. National Schools Master Shop Method Home Study course, with newly added lessons and equipment, can train you in your spare time, *right in your own home*, for these exciting opportunities. Our method has been proved by the remarkable success of National Schools-trained men all over the world.

### You Learn by Building Equipment with Standard Radio Parts We Send You

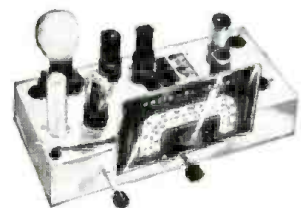

Your National Schools Course includes not only basic theory, but *practical* training as well—you learn *by doing*. We send you complete standard equipment of professional quality for building various experimental and test units. You advance step by step until you are able to build the modern superheterodyne receiver shown above, which is yours to keep and enjoy. You perform more than 100 experiments—build many types of circuits, signal generator, low power radio transmitter, audio oscillator, and other units. The Free Books shown above tell you more about it—send for them today!

Lessons and Instruction Material Are Up-to-date, Practical, Interesting

National Schools Master Shop Method Home Training gives you basic and advanced instruction in all phases of Radio, Television and Electronics. Each lesson is made easy to understand by numerous illustrations and diagrams. All instruction material has been developed and tested in our own shops and laboratories, under the supervision of our own engineers and instructors. A free sample lesson is yours upon request—use the coupon below.

You Get This and Other Valuable Information in the Free Sample Lesson:

Both Home Study and Resident Training Offered

1. Basic Receiver Circuits and How They are Used.
2. Construction of the Antenna Circuit.
3. How Energy is Picked Up by the Aerial.
4. How Signal Currents are Converted into Sound.
5. How the Tuning Condenser Operates.
6. How the R-F Transformer Handles the Signal, and other data, with diagrams and illustrations.

## APPROVED FOR VETERANS

Check Coupon Below

### Now! NEW PROFESSIONAL MULTITESTER INCLUDED:



This versatile testing instrument is portable and complete with test leads. Simple to operate, accurate and dependable. You will be able to quickly locate trouble and adjust the most delicate circuits. You can use the Multitester at home or on service calls. It is designed to measure AC and DC volts, current, resistance and decibels. You will be proud to own and use this valuable professional instrument.

## NATIONAL SCHOOLS LOS ANGELES 37, CALIFORNIA, EST. 1905 MAIL OPPORTUNITY COUPON FOR QUICK ACTION

NATIONAL SCHOOL, Dept. 9-RE  
4400 S. Figueroa, Los Angeles 37, Calif. Paste on a postcard

Mail me FREE the book "Your Future in Radio" including a sample lesson of your choice. I understand no salesman will call on me.

NAME ..... AGE .....

ADDRESS .....

CITY ..... Zone ..... STATE .....

Check here if Veteran of World War II

GET THE DETAILS—SEND THE COUPON →

# OVER \$1,000,000.00 IN SURPLUS!

FOR YOUR EVERY NEED



## NEW BC 223 AX TRANSMITTER

801 Oscillators and 801 power amplifiers. \$39.95  
2-46 modulators and 1-46 speech amplifier  
4 Xtal frequencies and master oscillator on selector switch. 30 Watt output. Tone voice or C.W. Mod. Ideal for 50 meter band. Comes with 3 coils TU 17A 2000-3000 Kc. TU 25 3500-5250 Kc. Black crackle case. Includes two separate cases to store extra coils. Frequencies chart and tubes included. Packed in original cases, less crystals at this low price.

## MODULATION TRANSFORMER AND DRIVER TRANSFORMER

RC 1206 modulation transformer. 815 Class AB2. 56W. audio. RC 1205 driver transformer. 65N7 to 815. Class AB2—Companion to RC 1206.

ONLY \$4.95 FOR BOTH UNITS

## MICA CAPACITATOR

.002 MFD 69c  
3000 W.V.D.C.

## INDUSTRIAL PAPER OIL CAPACITATORS

- 1. MFD 5000 V. \$2.95
- 1. MFD 6000 V. \$4.95
- 2. MFD 6000 V. \$8.95

## SPRAGUE CONDENSERS

.1 MFD 7000 Volts \$1.95

## COAXIAL FITTINGS

- 3c HOOD
  - 25c SOCKET
  - 35c PLUG
  - 20c ANGLE ADAPTER
- HOOD 50-239 83-1R  
SOCKET 50-239 83-1R  
PLUG PL-259 M-359  
ANGLE ADAPTER M-359 83-1AD

## BK 22 K RELAY

\$2.95 Used in conjunction with SCR-269F. changeover contains 28V. step relay 5 deck. 6 position switch. 12V DPST.



ARR7 AIRBORNE VERSION OF

## HALLICRAFTER SX 23A

\$129.00

With 3 RF stages. (One re-radiation suppressor R-F.) 12 tubes. Motor and manual tuning. S-meter. F-selectivity control. Crystal Filter. AVC. phasing control. ANL, etc. Also furnishes video output for scope, and panoramic output for scanning. Complete with tubes and kit, but without power supply. Power requirements, 270V.D.C. at 135 MA. and 6V.A.C. 6 Amperes. New, in sealed cases.

## ULTRA HIGH-FREQUENCY TRANSMITTER T-85/APT-5

BRAND NEW! ONLY \$95.00

1500 Mc. Transmitter, made for U.S. Government, complete with the following tubes: 2-6AC7, 1-6L6, 2-829, 1-931A, 1-6AG7, 1-522 Ultra high freq. tube. Complete with high freq. cavity. 1 Blower to cool the 522, 1 time delay relay, 2 filament trans. cond. and many other component parts for ultra high frequency work. It has a frequency checker, complete Lecher wires, with slider and sensitive bulb for checking the wave length. The Lecher wires are so calibrated that the setting of the slider may be read directly in Centimeters. Operates on 115V. AC for filaments only. Does not include any plate supply. The tubes alone are worth many times more than what we are selling the complete transmitter for. Packed in original case—contains instruction book. Wgt 118 lbs.

## T-17 CARBON MIKE

79c LIKE NEW

## SCOPE TRANSFORMER

\$3.95 Primary 110V. 60 Cy. Sec. 4000V. at 10 MA. Size 6x4x1 1/2".

## SELSYN MOTORS

TWO FOR \$3.95

The ideal way of indicating the position of Rotary beams, wind indicator, etc. Line chord and instructions for 110 AC operation furnished on request.

## IRC TYPE HE

100W. Bleeder consisting of 5 sections; 750 ohms, 23 ohms, 23 ohms, 7500 ohms, 300 ohms, Total—11,296 ohms. 49c

## 304TL 75c

Just the tube for that 1KW final — typical operation 2500 volts at 400 MA. An ideal tube for that induction heater or dielectric heater. Efficient operation at 1500V. to 3000V.

## TUBES

815	\$1.95	VR150	69	9006	.44	RK60	\$ .95
3BP1	1.95	955	.65	50B5	.89	1T4	.44
5FP7	.95	9002	.44	35W4	.69	3Q4	.44
7BP7	1.49	12X3	.44	872A	1.95	354	.44
9LP7	2.95	9004	.44	1H5	\$ .69	1N5	.69
C E PHOTOCELL	.95c	3Q5	.69	VT25			
Type used in movie projectors, burglar alarms, etc.		6L6GA	.95	(2101	.44		
		5U4G	.44	5W4	.44		
		6SA7	.44	2X2	.95		

## Butterfly Condensers

Oscillator assembly 76 to 300 MC with acorn tube socket mounted on condenser \$3.95  
Type B Frequency range 30v-1000 megacycles 2.95  
BC4 Antenna condenser 105-330 MC... 3.95  
Oscillator 105-330 M.C.... 3.95

## Remote Position Indicator

6-12V. 60 Cy. 5" Indicator with 0-360 Degree Dial. \$4.95

## Circuit Breaker, 24V, 20 Amp.

AN 3160 Squire D. Co. \$1.49

## Banana Jack and Plug

75c Dozen Sets

## THERMOSTAT

Normally opens at 95° F85-1 H5 49c

## 30 MC-1F, Silver-Slugged, 35c HEINEMANN CIRCUIT BREAKER

- 115 V. 5 Amp. 95c
- 110 V. 15 Amp. \$1.95
- 110 V. 20 Amp. \$1.49

Klixon 110 V. 5 Amp. Adjustable

95c Air-craft

## A-5 AUTOMATIC PILOT

Serve—100 pounds max. to use as a steering device, or compass control on ships. \$9.95

## CONTROL BC 1103

Made by General Electric. Contains FUSE

F301 20A 250V G.E. CAT. GE 1025 INDICATOR LAMP  
1301 Mounting G.E. DWG. K7887817 P1  
1301A 115V 6W G.E. Mazda Type S6 RECEPTACLES

J301 3 POLE RUSSELL STOLE F6852  
J302 2 POLE HART & HEGEMAN F7723  
J303 2 POLE HART & HEGEMAN -7723  
J304 4 POLE RUSSELL STOLE 8087 RELAY

K301 120V 60n STRUTHERS DUNN AS8X1 SWITCHES  
S301 ALLEN BRADLEY CAT. 2AS  
S302 INTERLOCK 10A 250V

PRICED AT ONLY \$4.95

No. MX16 Cross pointer 3 1/2" Meter. Two 200 microamp movements. Brand new \$2.95  
500 ohm to grid matching transformer \$4.95  
No. 81749 Ceramic mica Padder single 5 to 20 MMFD 69c

Choke—300MA 20HY. Insulated for 5000V. Heavy Porcelain Insulators. Very conservatively rated. Idle for KW rig \$6.95

## PHILCO FURNITURE OR REFRIGERATOR POLISH

Reg. 49c value for 19c each  
8 oz. Can \$1.95  
Mfgd. by Philco Radio & Television Co. \$3.50 for Case of 24

## Don't Miss These Special Savings!

- Powdered iron, 3/4 slug 10c
- Jacks for PL55 10c
- Ass't mica condensers—per 100 \$1.95
- Pin straightener for miniature tubes 25c
- Ear phones, 2000 ohms, used 95c
- SCR625 Mine detector, used \$39.50
- 75,000-ohm 200 watt Bleeder Res. 95c

## Beautiful DETROLA Record Changer



Handles 12-10" records or 10-12" records. Automatic Changer—Only

\$9.95

## Be a "Forty-Niner" in '49

## THE "FORTY-NINER" GEIGER COUNTER

\$89.50



- Light weight uranium detector.
  - Detects beta and gamma rays.
  - Equipped with 36 inch search probe.
  - Contains two 67 1/2 volt Minimax batteries in the well-known type of relaxation oscillator supply.
- Weight 4 1/2 lbs. complete; size 4"x5"x6". Beautifully finished case with handle.  
Complete with four tubes, including Geiger tube, batteries, search probe and ear-Phone.

## FM RADIO AND TRANSMITTER BC-630-A

20 MC TO 27.9 MC \$9.95

This Xtal controlled FM set has 13 tubes and has dual Xtal controlled channels. It also contains built-in Fil. and Plate Meter. Tubes used: (1)1LN5, (1)1LE6, (1)1LH4, (1)1291, (1)1291, (1)1291. Ideal for communication between trucks, boats, etc. Used in good condition. Less power supply. Wt. 38 lbs. Complete with carrying case and diagrams.

Write for Free Catalog

## HERSHEL RADIO CO

DEPT R. E. 9

5249 GRAND RIVER

DETROIT 8, MICHIGAN

All orders F.O.B. Detroit—Minimum order \$2.00—Michigan customers add 3% sales tax—20% payment must accompany all orders.



don't let  
others  
put  
you  
out of  
the  
picture!



## Here's How CREI Home Study Training Prepares You NOW For a Better Job and a Secure Future in **TELEVISION!**

**G**ET IN and *get ahead* in Television! You can make your own opportunity if you start preparing *now*. No need to tell you how fast Television is expanding—or, of the number of jobs being created. One of industry's leaders predicts: *1 Million Persons in TV within 4 years!* He estimates 12 Million TV sets by 1953—40 Million by 1958.

If your future is in radio, you *must* get in Television. CREI offers the very training you need to go after—and get—a good TV job.

CREI can show you the way with convenient spare-time study at home that gives you the up-to-date technical background you *must* have for Television. CREI courses are designed to give you a thorough grounding in basic principles and take you step-by-step through the more advanced subjects of TV and its related fields. It must be remem-

**VETERANS: CREI TRAINING AVAILABLE UNDER G.I. BILL**  
For Most Veterans July 25, 1951 Is Deadline—ACT NOW!

If you have had professional or amateur radio experience and want to make more money, let us prove to you we have the training you need to qualify for a better radio job. To help us answer intelligently your inquiry—*please send briefly your background of experience, education and present position.*



## Capitol Radio Engineering Institute

An Accredited Technical Institute Founded in 1927

Dept. 149-A, 16th and Park Road, N. W., Washington 10, D. C.

Branch Offices: New York (7) 170 Broadway • San Francisco (2) 760 Market St.

bered that all new electronic developments have their roots in past techniques. The basic theory of TV finds application in every field—aeronautical radio, UHF, wide band operation, etc. are based on TV techniques. Your CREI training becomes important no matter in what direction you are heading. You will find CREI training basic and helpful right from the start. You will learn about and understand such subjects as: Optics, Pulse Techniques, Deflection Circuits: RF, IF, AF and Video Amplifiers: FM: Receiving Antennas: Power Supplies: Cathode Ray, Iconoscope, Image Orthicon and Projection Tubes: UHF Techniques, Television Test Equipment, etc.

### FREE SAMPLE LESSON

Now, see for yourself! Mail the coupon for free sample lesson and see how interesting it is to study at home and improve your income through ability the CREI way.

#### "THE ORTHICON AND IMAGE ORTHICON"

This lesson describes the development of the small 3-inch image orthicon tube; theory and operation of the orthicon, image orthicon; specific features.



### MAIL COUPON FOR FREE BOOKLET

CAPITOL RADIO ENGINEERING INSTITUTE  
16th & Park Road N. W., Dept. 149A, Washington 10, D. C.  
Gentlemen: Please send your free sample lesson and booklet, "Your Future in the New World of Electronics," together with full details of your home-study training. I am attaching a brief resume of my experience, education and present position.  
Check field of *are* test interest:

- |   |   |
|---|---|
| <input type="checkbox"/> PRACTICAL RADIO ENGINEERING              | <input type="checkbox"/> PRACTICAL TELEVISION ENGINEERING       |
| <input type="checkbox"/> BROADCAST RADIO ENGINEERING (AM, FM, TV) | <input type="checkbox"/> TELEVISION, FM & ADVANCED AM SERVICING |
| <input type="checkbox"/> AERONAUTICAL RADIO ENGINEERING           | <input type="checkbox"/> ADVANCED ELECTRONICS COMMUNICATIONS    |
|   | <input type="checkbox"/> RADIO-ELECTRONICS IN INDUSTRY          |

NAME .....  
STREET .....  
CITY ..... ZONE ..... STATE .....  
 I AM ENTITLED TO TRAINING UNDER G. I. BILL.

## Announcing the RADIO & TELEVISION LIBRARY



A complete library covering everything in Radio and Television in over 1800 pages, completely illustrated! Two handsomely bound books (contents described below) in attractive slip case . . . compact, concise, complete!

**Over 1800 Pages \$9.00**

### VIDEO HAND BOOK

Now in one great book, all the essential knowledge of television for laboratory technician, experimenter, serviceman . . . everyone interested in or working at television! Complete, up-to-the-minute information arranged for quick reference, easy to read . . . no mathematics. Over 900 pages . . . more than 800 photographs, diagrams and drawings. Here are some of the subjects covered: Fundamentals, the TV station, the receiver, antennas, programming, installation, service, test equipment, data, terms, etc., etc.



**\$5.00**

### RADIO DATA BOOK

The only radio handbook of its kind! Covers everything in Radio for lab technicians, experimenters, servicemen, everyone and anyone! Over 900 pages, 12 big sections with hundreds of drawings and diagrams. Some of the subjects covered are . . . Testing, Measuring and Alignment . . . All about Antennas . . . Sound Systems . . . Recording . . . Complete Test Equipment Data . . . Complete Tube Manual . . . Charts, Graphs and Curves . . . 50 Tested Circuits . . . Codes, Symbols and Standards . . . 150 Basic Circuits . . . Dictionary of Radio Terms . . . etc., etc.



**\$5.00**

## RADIO DISTRIBUTION AND MAINTENANCE

The complete trade tool all devoted to sales and service of Radio, Video, and TV.  
Single copies 25¢ \$3.00 per year, \$5.00 2 years

All products of  
**BOLAND & BOYCE INC., Montclair 3, N.J.**  
are available at your  
local distributor's counters. Order now!

**BOLAND & BOYCE INC., PUBLISHERS**

**ELECTRONIC BRAIN** which stores vast amounts of information, any piece of which is available, was demonstrated last month by the Departments of Commerce and Agriculture in Washington. Known as the Rapid Selector, the machine was developed from principles originated before the war by Dr. Vannevar Bush.

The Rapid Selector makes use of standard 35-mm motion picture films, on each reel of which can be stored the contents of almost 500,000 conventional library cards.

When the information is microfilmed, a predetermined code pattern consisting of black and white squares is simultaneously printed on the film indicating the subject to which the information relates.

The operator of the machine, wishing to obtain everything the selector possesses on a particular subject, places a master key card in the mechanism. The selector's photoelectric eyes then scan the film at a rate of more than 60,000 subjects a minute, automatically select the desired frames, and copy them on a separate film through the use of high-speed photoflash techniques.

This development is of inestimable value in research where all references in a particular field must be thoroughly checked before undertaking new work. Depending on the subject matter and the extensiveness of previous researches, a hunt for references which took days or weeks with old methods can now be completed in less than half an hour.

The selector, which can potentially be coded for 10,000,000 different subjects, uses photoelectric cells. The Rapid Selector scans the patterns of light and dark accompanying each film frame "looking" for a particular pattern to match the master key inserted in the

machine. When the two coincide, a flashlamp is fired photographing the frame passing through the scanning area at that instant.

This flash results in a copy of the item of information desired by the operator. When a complete reel has passed through the machine, the researcher has a complete and accurate bibliography of the subject in a minimum of time.

**THEATRE TV PLANNERS** were asked last month by the FCC for a definition of their plans. Letters were addressed by the Commission to Paramount Television Productions, Inc., Twentieth Century-Fox Film Corp., and the Society of Motion Picture Engineers asking that answers to six questions be submitted by September 2. The inquiries were:

1. Minimum requirements for a competitive nationwide theatre service.
2. Proposed frequency bands.
3. Uses of each frequency.
4. Whether some or all functions could be performed by co-axial cable or by some other means not requiring radio spectrum space.
5. Whether common carriers will be involved.
6. Specific plans for establishing a theatre TV service.

Paramount and Fox were asked for reports on their experimental relay stations in the New York area.

**TELEVISION RECEPTION** was affected in the New York area by last month's heat. Some set owners were getting poor pictures or none at all. Strange patterns of lines and rumbling, gurgling sounds were reported by Eugene Anthony, television service manager for General Electric. Many cases of unusual long-distance reception were reported.

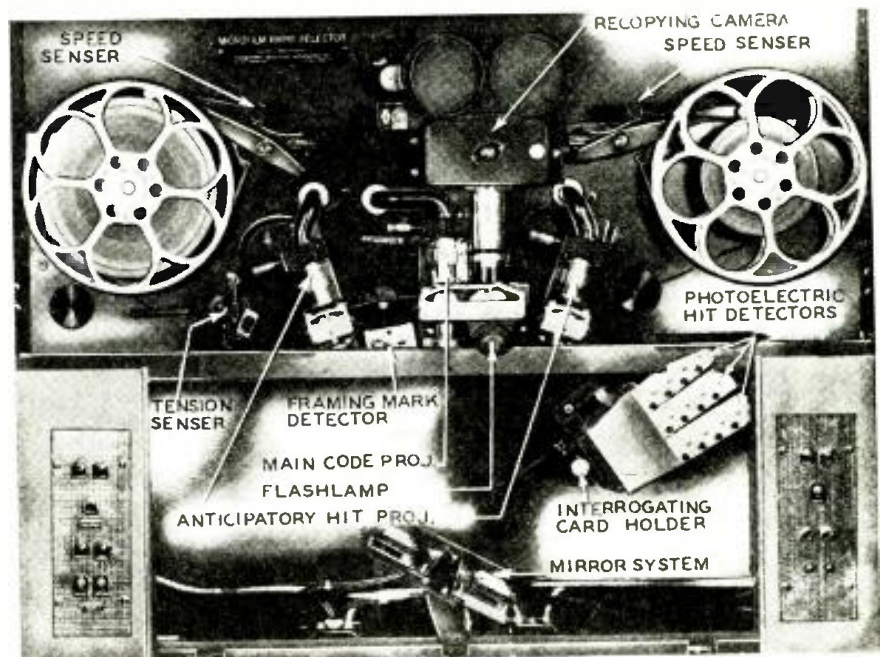

This photograph of the interior of the Rapid Selector reveals the principal working parts.

RADIO-ELECTRONICS for



**RATTLESNAKE** put station WWWR in Russelville, Ala., off the air for over an hour one day last month. A 3-foot rattler crawled into the tuning unit and caused a short-circuit. In Lyon, France, a camel caused another radio station breakdown. After the station went off the air, technicians discovered the camel calmly eating parts of the antenna.

**TV FILMS** showing receiver owners how to care for their sets will be made for the RMA with the cooperation of Television Broadcasters Association, the RMA Town Meetings committee voted last month. A major purpose of the films will be to help reduce the number of nuisance calls on service technicians, especially those caused by lack of knowledge of television receiver capabilities and of tuning and adjustment procedures.

The proposal was sparked by information gained from technicians at the six Town Meetings sponsored last year by RMA. The films will be made available to all TV stations for broadcast at will.

**DR. VLADIMIR K. ZWORYKIN**, vice president and Technical Consultant of the RCA Laboratories Division, received the Lamme Medal, an outstanding award for scientific and technical achievement, from the American Institute of Electrical Engineers at its annual meeting at Swampscott, Mass.

Dr. Zworykin was awarded the medal "for his outstanding contribution to the concept and design of electronic ap-



paratus basic to modern television." The award, established in 1928 through a bequest of Benjamin Garver Lamme, chief engineer of the Westinghouse Electric & Manufacturing Co., was presented by Everett S. Lee, Institute president.

**METERED VIDEO** was tried for the first time last month by a major television manufacturer, Crosley, in New York. The firm is offering to install receivers, together with a "visimeter". The meter provides the purchaser with one hour of TV viewing for each quarter he inserts in the slot. The money is collected periodically and applied toward the purchase price of the set.

**SERVICE CONTRACTS** between television receiver owners and independent contractors are illegal in New York State, ruled New York Attorney-General Nathaniel L. Goldstein last month. Asked for an interpretation of the state statutes by the head of the State Insurance Department, the attorney-general said that independent contractors—organizations other than manufacturers or sellers of the receivers involved—were selling insurance, under the legal definition. Not having complied with the requirements set up by the Insurance Department for insurance companies, these contractors apparently have been violating the law.

Attorney-General Goldstein made it clear, however, that a contract made by the *seller* or *manufacturer* of a receiver for service and parts replacement during the initial period of the set's use constitutes a warranty, even though extra payment may be made for it; it is not, therefore, a violation. Such warranties *cannot* be renewed.

As noted in the August editorial, many independent television service contractors have been going into bankruptcy because of the unexpectedly high costs of fulfilling service contracts. The New York attorney-general's interpretation is likely to alter the entire structure of the television service industry.

The few receiver manufacturers who maintain their own field service organizations will be affected only to the extent that their contracts will not be renewable unless they are licensed by the State Insurance Department.

**CRYSTALS** which hold their frequency indefinitely and are more accurate than any previous types are being made for the armed forces, the U. S. Army Signal Corps announced last month. A revolutionary new manufacturing process is expected to save large amounts of money because of the long life of the new crystals and to allow closer radio station frequency assignments because of their accuracy.

The new process, developed by three Signal Corps physicists, Arthur C. Prichard, Maurice A. A. Druesne, and Dr. David G. McCaa, involves heating the crystals to approximately 900 degrees F. and then cooling them slowly under precisely controlled conditions. The blank crystals are placed on a conveyor belt and passed through an electric oven for two to three hours. Cooling takes a full 24 hours.

The high Q of the crystals will make smaller equipment possible by doing away with the need for some of the present amplifier stages. Used for controlling standard clocks, the crystals may also make possible a new, more accurate definition of the second.

**RADIOLYMPIA**, Britain's sixteenth national radio exhibition, will be held at Olympia Exhibition Hall in London from Wednesday, September 28 to Saturday, October 8, 1949. The last Radiolympia was held in the autumn of 1947. The exhibition will include all types of radio and electronic equipment.

You can do every kind of soldering with this new 250 watt Weller Gun. Power-packed, it handles heavy work with ease—yet the compact, lightweight design makes it equally suited for delicate soldering and getting into tight spots.

Pull the trigger switch and you solder. Release the trigger, and off goes the heat—automatically. No wasted time. No wasted current. No need to unplug the gun between jobs. "Over and under" position of terminals provides greater visibility with built-in spotlight. Extra 5 1/4" length and new RIGID-TIP mean real soldering efficiency.

Chisel-shape RIGID-TIP offers more soldering area for faster heat transfer, and new design gives bracing action for heavy jobs. Here you get features not found in any other soldering tool... advantages that save hours and dollars. Your Weller Gun pays for itself in a few months. Order from your distributor or write for bulletin direct.

**SOLDERING TIPS**—get your copy of the new Weller guide to easier, faster soldering—20 pages fully illustrated. Price 10c at your distributor, or order direct.

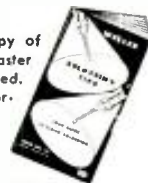

**WELLER**  
MANUFACTURING COMPANY  
828 PACKER STREET • EASTON, PA.

# use *Telrex* "V" BEAM CONICAL ANTENNAS

...for better reception on all TV and FM channels

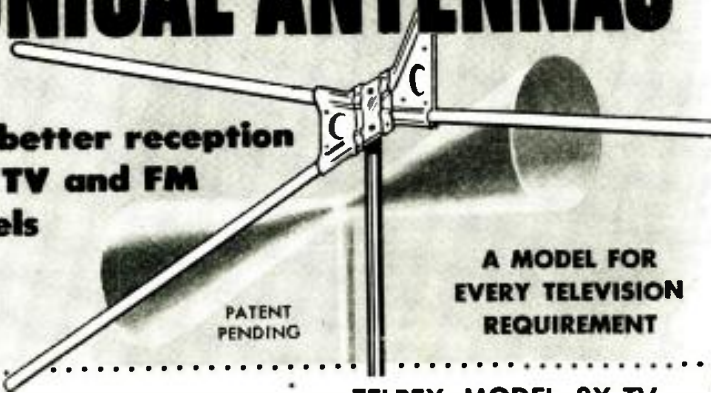

A MODEL FOR EVERY TELEVISION REQUIREMENT

## TELREX MODEL 1X-BD



Bi-Directional Hi-Gain Conical "V" Beam  
Broad Band Full Audio and Video Band Pass  
Low Vertical Angle  
Non-Varying Center Impedance 2 to 1 Front to Back Ratio  
Uses 72, 150 or 300 Ohm Transmission Lines  
Universal Mounting Clamp

## TELREX MODEL 8X-TV



4 Bay Conical "V" Beam  
Broad Band Full Audio and Video Band Pass  
Low Vertical Angle, Minimum Reflections  
Maximum Signal to Noise Ratio 12 DB Front to Back Ratio, all Frequencies  
150 Ohm Constant Center Impedance  
Uses 72, 150 or 300 Ohm Transmission Lines  
Universal Mounting Clamp

**OVER 12 DB FRONT TO BACK RATIO — ALL FREQUENCIES  
— NO HIGH FREQUENCY HEAD NEEDED WITH TELREX**

## TELREX MODEL 2X-BD



Bi-Directional Stacked Conical "V" Beam  
Low Vertical Angle  
Extremely High Signal to Noise Ratio  
Constant Center Impedance  
Uses 72, 150 or 300 Ohm Transmission Lines  
Universal Mounting Clamp

FOR THE ULTIMATE IN BI-DIRECTIONAL GAIN. USE TELREX MODEL 4X BD.

## TELREX MODEL 2X-TV



Uni-Directional Conical "V" Beam  
Broad Band — Full Audio and Video Band Pass  
Low Vertical Angle, Minimum Reflections  
Maximum Signal to Noise Ratio 4 to 1 Front to Back Ratio all Frequencies  
Universal Mounting Clamps

**BEFORE YOU LABEL ANY AREA IN YOUR LOCALITY REMOTE FOR TV — CHECK WITH TELREX!**



### ALL TELREX ELEMENTS ARE MADE OF LASTING DURAL

For best results in any TV area, use Telrex — the highest gain antenna with constant center impedance on all channels. Signals received at the antenna are carried to the set with negligible loss and no reflections or ghosts. Actual case records show Telrex antennas receiving satisfactorily 200 miles over land, 300 miles over all-water TV paths. Before you say "too remote", check with Telrex.

We'll give you an impartial, based-on-experience opinion — without obligation.

COPYRIGHTED 1949

**Telrex INC**

ASBURY PARK 10, NEW JERSEY

AMERICA'S OUTSTANDING TELEVISION BEAM

Radio Manufacturers Association president R. C. COSGROVE appointed an RMA Town Meeting Committee to consider future activities in behalf of radio and television service technicians. ROBERT C. SPRAGUE, president of the Sprague Electric Co., North Adams, Mass., was named chairman of the committee. Other members are: BENJAMIN ABRAMS, Emerson Radio & Phonograph Corp., New York; A. T. ALEXANDER, Motorola, Inc., Chicago; W. R. G. BAKER, General Electric Co., Syracuse, N. Y.; H. C. BONFIG, Zenith Radio Corp., Chicago; LEONARD F. CRAMER, Allen B. Dumont Laboratories, Inc., Passaic, N. J.; HARRY A. EHLE, International Resistance Co., Philadelphia, Pa.; J. B. ETIOT, RCA-Victor Division of RCA, Camden, N. J.; G. M. GARDNER, Wells-Gardner & Co., Chicago; LARRY F. HARDY, Philco Corp., Philadelphia, Pa.; H. L. HOFFMAN, Hoffman Radio Corp., Los Angeles; J. J. KAHN, Standard Transformer Corp., Chicago; STANLEY H. MANSON, Stromberg-Carlson Co., Rochester, N. Y.; LESLIE F. MUTER, The Muter Co., Chicago; and A. D. PLAMONDON, Jr., The Indiana Steel Products Co., Chicago.

Six Town Meetings for radio and television service technicians were held under RMA sponsorship in 1948 and the early part of 1949.

Annual Pacific Electronic Exhibit will be held in the Exposition Auditorium at the Civic Center, San Francisco, California, August 30 and 31 and September 1, 1949. The annual Western Regional convention of the Institute of Radio Engineers will meet concurrently in the same building.

Association of Electronic Parts And Equipment Manufacturers went on record at its June meeting in Chicago as endorsing a plan to open the annual Radio Parts Show to all manufacturers who sell through distributors, regardless of association membership, and recommended that no attendance restrictions be imposed during Show hours. Present Show rules require membership in one of the five co-sponsoring groups to exhibit.

Radio Manufacturers Association reported that May sales of radio receiving tubes decreased slightly under sales in April. Tube sales in May totalled 13,488,121, compared with 13,593,164 in April, and brought the number of tubes sold by RMA member-companies in the first five months of this year to 67,739,328.

A breakdown of the receiving tube figures shows 9,284,019 tubes sold for new sets; 3,465,017 for replacements; 698,510 for export; and 40,575 tubes sold to government agencies.

National Electronics Conference will be held from September 26 to 28 at the Edgewater Beach Hotel in Chicago.

Radio Corporation of America has contracted for permanent installation of instantaneous TV projection equipment soon to be installed in Fabian's Brooklyn Fox Theater.





**SENSATIONAL**

**New Training Offer!**

**NOW you build and keep a top quality**

**TELEVISION**

**RECEIVER**

to help you prepare for a real job in

**TELEVISION RADIO-ELECTRONICS**

**Choice of 10, 12 or 16 INCH TELEVISION PICTURE TUBE**

Now you can get this amazingly practical aid for learning Television at home, to help you get started toward **FASCINATING WORK... GOOD MONEY... a THRILLING FUTURE** — in a real job, or your own sales and service business. • When you complete our regular home training—described below—you can build and keep a top quality commercial-type Television Receiver. Standardized chassis is adaptable for a 10, 12 or 16 inch direct view tube that gives big, bright, sharp, steady pictures. This is an optional training advantage — designed to provide the utmost in practical "learn-by-doing" home training in Television. Mail coupon for complete details. See why you owe it to your "Television Future" to enroll for DeForest's Training, Inc.

**Mail Coupon NOW for FREE Information!**

See how D. T. I.'s amazingly effective methods help start you toward a **GOOD JOB** or your **OWN BUSINESS** in one of America's most promising fields — including Television, F. M. Radio, Aviation, Train, and Taxi Radio, Broadcast Radio, Industrial Electronics. Get modern lessons... **plus 16 shipments** of Radio-Electronic parts. Work over 300 experiments and projects — including building of (1) commercial-type **OSCILLOSCOPE** for practical T-V circuit training, (2) double-range **R-F SIGNAL GENERATOR**, (3) jewel-bearing **MULTIMETER**, (4) quality 6-tube **SUPERHET RADIO**. Then build and keep that big new Television Receiver. Here's **EVERYTHING YOU NEED** for real laboratory-type training... **AT HOME!**

**Modern Chicago Laboratories**

★ If you prefer, you can get **ALL** your preparation in our new, Chicago training laboratories... one of the finest of its kind. Ample instructors... modern equipment. Write for details!

**Employment Service**

★ When you complete your training, our effective Employment Service helps you get started toward a real future in Television — Radio — Electronics.



**You also use HOME MOVIES!**  
a D. T. I. Exclusive!

D. T. I. alone includes the modern, visual training aid... **MOVIES**... to help you learn faster, easier at home. See electrons on the march and other fascinating "hidden action" — a remarkable home training advantage that speeds your progress.

**YOU ALSO BUILD AND KEEP THIS PROFESSIONAL TYPE EQUIPMENT!**



**MAIL THIS COUPON TODAY!**

**DeFOREST'S TRAINING, INC.**  
2533 North Ashland Avenue, Dept. RC-F9  
Chicago 14, Illinois

Without obligation, give me complete facts showing how I may make my start in Television-Radio-Electronics.

Name \_\_\_\_\_ Age \_\_\_\_\_  
Street \_\_\_\_\_ Apt \_\_\_\_\_  
City \_\_\_\_\_ Zone \_\_\_\_\_ State \_\_\_\_\_

**De FOREST'S TRAINING, INC.**  
CHICAGO 14, ILLINOIS  
A DE VRY Institution

**IT'S  
SYLVANIA  
AGAIN!**

**ION TRAP IN SYLVANIA  
TELEVISION TUBES  
ASSURES HUNDREDS  
OF HOURS FREE FROM  
SCREEN BURNS**

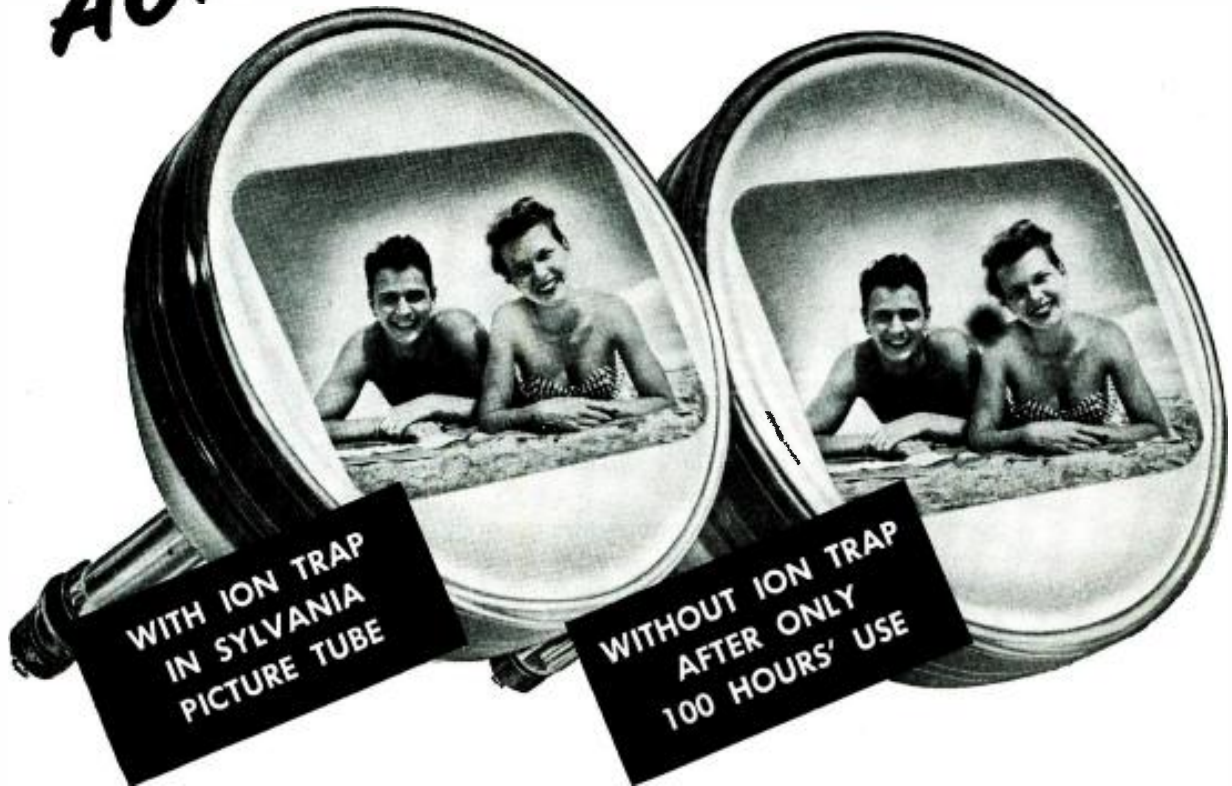

**HERE'S HOW IT WORKS . . .**

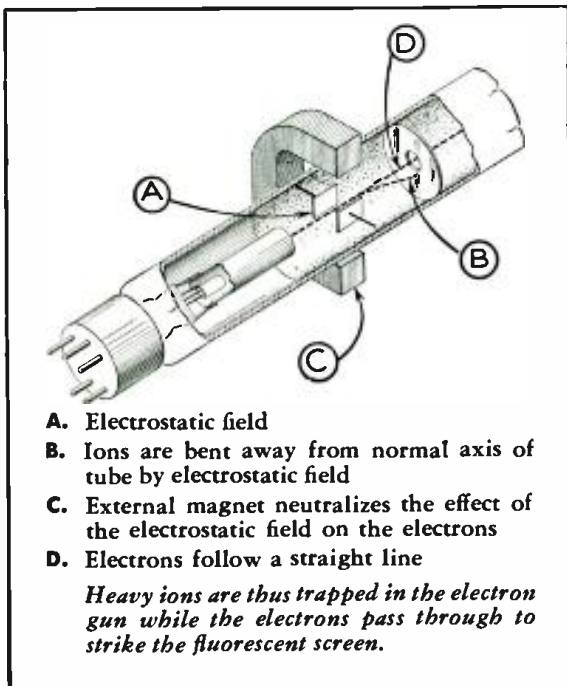

Owners of television sets equipped with Sylvania Television Picture Tubes report their screens still bright and unblemished after more than 1000 hours' use. Much credit for this top quality performance belongs to Sylvania scientists who hold the basic patents on the magic "ion trap." With this device these scientists prevented destruction of the fluorescent screen by heavy ion bombardment. So successful is this ion trap that now many other major TV tube makers are using it under agreements with Sylvania.

These same Sylvania Television Tube scientists are now developing shorter large-screen picture tubes and special tubes for uhf television. Their continued research makes the Sylvania label your guarantee of the newest and finest in television picture tubes. Sylvania has a complete line of all-glass and glass-metal types for television and general purpose cathode ray applications. They are available now from your Sylvania Distributor.

Write for free characteristics and TV set complement chart. Advertising Department, Box R-1709, Emporium, Pa.

**SYLVANIA  
ELECTRIC**

RADIO TUBES; CATHODE RAY TUBES; ELECTRONIC DEVICES; FLUORESCENT LAMPS,  
FIXTURES, WIRING DEVICES, SIGN TUBING; LIGHT BULBS; PHOTOLAMPS

RADIO-ELECTRONICS for



NEW 1950

# Heathkits

have all the Features

New 1950 Heathkit

## PUSH-PULL EXTENDED RANGE 5" OSCILLOSCOPE KIT

### Features

- The first truly television oscilloscope.
- Tremendous sensitivity .06 Volt RMS per inch deflection.
- Push-pull vertical and horizontal amplifiers.
- Useful frequency range to 2½ Megacycles.
- Extended sweep range 15 cycles to 70,000 cycles.
- New television type multivibrator sweep generator.
- New magnetic alloy shield included.
- Still the amazing price of \$39.50.

The new 1950 Push-Pull 5" Oscilloscope has features that seem impossible in a \$39.50 oscilloscope. Think of it—push-pull vertical and horizontal amplifiers with tremendous sensitivity only six one hundredths of a volt required for full inch of deflection. The weak impulses of television can be boosted to full size on the five inch screen. Traces you couldn't see before. Amazing frequency range clear useful response at 2½ Megacycles made possible by improved push-pull amplifiers. Only Heathkit Oscilloscopes have the frequency range required for television. New type multi-vibrator sweep generator with more than twice the frequency range. 15 cycles to 70,000 cycles will actually synchronize with 250,000 cycle signal. Dual positioning controls will move trace over any section of the screen for observation of any part. New magnetic alloy CR tube shield protects the instrument from outside fields. All the same high quality parts, cased electrostatically shielded power transformer, aluminum cabinet, all tubes and parts. New instruction manual now has complete step by step pictorials for easiest assembly. Shipping Weight 30 lbs. Order now for this winter's use.

#### CONVERSION FOR OTHER MODEL HEATHKIT OSCILLOSCOPES

A conversion for all 03 and 04 scopes is available changing them to the new push-pull amplifiers (does not change the sweep generator). Complete kit includes new chassis, tubes and all parts. For a small investment, add the latest improvements to your present oscilloscope (Except C.R. Tube Shield). Shipping weight 10 lbs. Order 05 Conversion Kit No. 315..... \$12.50



**\$39.50**

## THE NEW Heathkit HANDITESTER KIT

MORE Features THAN EVER BEFORE

- Beautiful streamline Bakelite case.
- AC and DC ranges to 5,000 Volts.
- 1% Precision ceramic resistors.
- Convenient thumb type adjust control.
- 400 Microampere meter movement.
- Quality Bradley AC rectifier.
- Multiplying type ohms ranges.
- All the convenient ranges 10-30-300-1,000-5,000 Volts.
- Large quality 3" built-in meter.

The instrument for all—the ranges you need—beauty you'll enjoy for years and you can assemble it in a matter of minutes—an instrument for everyone. The handiest quality voltohmmeter of all. Small enough to put in your pocket yet a full 3" meter. Easy pictorial wiring diagrams eliminate all assembly problems. Uses only 1% precision ceramic divider resistors and wire wound shunts. Twelve different ranges. AC and DC ranges of 10-30-300-1,000-5,000 Volts. Ohms ranges of 0-3,000 ohms and 0-300,000 ohms. Milliampere ranges of 10MA and 100MA. Hearing aid type ohms adjust control fits conveniently under thumb for one hand adjustment. Banana type jacks for positive low resistance connections. Quality test leads included. The high quality Bradley instrument rectifier was especially chosen for linear scales on AC. The modern case was styled by Harrah Engineering for this instrument. The 400 microampere meter movement comes already mounted in the case protected from dust during assembly. An ideal classroom assembly instrument useful for a lifetime. Perfect for radio service calls, electricians, garage mechanics, students, amateurs and beginners in radio. The only quality voltohmmeter under \$20.00. An hour of assembly saves you one-half the cost and quality parts give you a better instrument. Order today. Shipping weight 2 lbs.

**\$13.50**



Note  
HANDY  
OHMS  
ADJUST.

EXPORT DEPT.  
13 East 40th St.  
NEW YORK CITY (16)  
CABLE: ARLAB-N.Y.

The **HEATH COMPANY**

... BENTON HARBOR 20, MICHIGAN

# Beauty · Quality · Economy



Only  
**\$69.50**

Nothing  
ELSE TO BUY

## New Heathkit IMPEDANCE BRIDGE KIT

A LABORATORY INSTRUMENT NOW WITHIN  
THE PRICE RANGE OF ALL

Measures Inductance from 10 microhenries to 100 henries capacitance from .00001 MFD to 1000 MFD. Resistance from .01 ohms to 10 megohms. Dissipation factor from .001 to 1. "Q" from 1 to 1000.

Ideal for schools, laboratories, service shops, serious experimentors.

An impedance bridge for everyone — the most useful instrument of all, which heretofore has been out of the price range of serious experimentors and service shops. Now at the lowest price possible. All highest quality parts. General Radio main calibrated control. General Radio 1000 cycle hummer. Mallory ceramic switches with 60 degree indexing — 200 micro-amp zero center galvanometer — 1/2 of 1% ceramic non-inductive decade resistors. Professional type binding posts with standard 3/4" centers. Beautiful birch cabinet. Directly calibrated "Q" and dissipation factor scales. Ready calibrated capacity and inductance standards of Silver Mica, accurate to 1/2 of 1% and with dissipation factors of less than 30 parts in one million. Provisions on panel for external generator and detector. Measure all your unknowns the way laboratories do — with a bridge for accuracy and speed.

Internal 6 volt battery for resistance and hummer operation. Circuit utilizes Wheatstone, Hay and Maxwell circuits for different measurements. Supplied complete with every quality part — all calibrations completed and instruction manual for assembly and use. Deliveries are limited. Shipping weight, approximately 15 lbs.



### 10,000V. H. V. TEST PROBE KIT

No. 310. Extends range of any 11 megohm VTVM to 3,000 and 10,000 Volt ranges. A necessity for television. Shipping Wt., 1 pound. **\$4.50**

### R. F. CRYSTAL TEST PROBE KIT

No. 309 Kit to assemble. R.F. probe extends VTVM range to 100 Mc. Complete with 1N34 crystal. Ship. Wt., 1 lb. ... **\$6.50**



### New Heathkit TOOL KIT

Now a complete tool kit to assemble your Heathkit. Consists of Krauter diagonal cutters and pointed nose assembly pliers, Xcelite screwdriver, 60 Watt 110V. soldering iron and supply of solder. Shipping Wt. 2 lbs. Complete kit **\$5.95**

## New Heathkit TELEVISION ALIGNMENT GENERATOR KIT

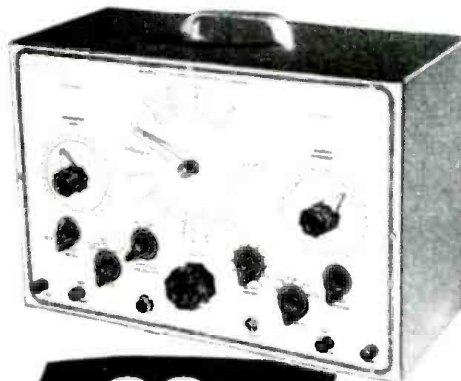

**\$39.50**

Nothing ELSE TO BUY

Everything you want in a television alignment generator. A wide band sweep generator covering all FM and TV frequencies 0-110 and 165 to 220 Megacycles, a marker indicator covering 19 to 43 Megacycles, AM modulation for RF alignment — variable calibrated sweep width 0-30 Mc. — mechanical driven inductive sweep. Husky 110V. 60 cycle power transformer operated — step type output attenuator with 10,000 to 1 range — high output on all ranges — band switching for each range — vernier driven main calibrated dial with over 45 inches of calibration — vernier driven calibrated indicator marker tuning. Large grey crackle cabinet 16 1/2" x 10 3/8" x 7-3/16". Phase control for single trace adjustment. Uses four high frequency triodes plus 5Y3 rectifier — split stator tuning condensers for greater efficiency and accuracy at high frequencies — this Heathkit is complete and adequate for every alignment need and is supplied with every part — cabinet — calibrated panel — all coils and condensers wound, calibrated and adjusted. Tubes, transformer, test leads — every part with instruction manual for assembly and use. Actually three instruments in one — TV sweep generator — TV AM generator and TV marker indicator. Also covers FM band.

EXPORT DEPT.  
13 East 40th St.  
NEW YORK CITY (16)  
CABLE: ARLAB-N.Y.

# The HEATH COMPANY

... BENTON HARBOR 20, MICHIGAN

RADIO-ELECTRONICS for



# all in HEATHKITS...

## Heathkit TUBE CHECKER KIT

### Features

1. Measures each element individually
2. Has gear driven roller chart
3. Has lever switching for speed
4. Complete range of filament voltages
5. Checks every tube element
6. Uses latest type lever switches
7. Uses beautiful shatterproof full view meter
8. Large size 11" x 14" x 4" complete
9. Checks new 9 pin pinatures

Check the features and you will realize that this Heathkit has all the features you want. Speed — simplicity — beauty — protection against abuse. The most modern type of tester — measures each element — beautiful Bad-Good scale, high quality meter — the best of parts — rugged oversize 110V. 60 cycle power transformer — finest of Mallory switches — Centralab controls — quality wood cabinet — complete set of sockets for all type tubes including blank spare for future types — fast action gear driven roller chart uses brass gears to quickly locate and set up any type tube. Simplified switching cuts necessary time to minimum and saves valuable service time. Short and open element check. No matter what arrangement of tube elements, the Heathkit flexible switching arrangement easily handles it. Order your Heathkit Tube Checker today. See for yourself that Heath again saves you 3/5 and yet retains all the quality — this tube checker will pay for itself in a few weeks — better build it now.

Complete with detail instructions — all parts — cabinet — roller chart — ready to wire up and operate. Shipping Wt., 15 lbs.



Only  
**\$29<sup>50</sup>**

Nothing  
ELSE TO BUY

## Heathkit SINE AND SQUARE WAVE AUDIO GENERATOR KIT



Nothing  
ELSE TO  
BUY

**\$34<sup>50</sup>**

Experimenters and servicemen working with a square wave for the first time invariably wonder why it was not introduced before. The characteristics of an amplifier can be determined in seconds compared to several hours of tedious plotting using older methods. Stage by stage, amplifier testing is as easy as signal tracing. The low distortion (less than 1%) and linear output (± 0.1 db) make this Heathkit equal or superior to factory built equipment selling for three or four times its price. The circuit is the popular RC tuning circuit using a four gang variable condenser. Three ranges 20-200, 200-2,000, 2,000-20,000 cycles are provided by selector switch. Either sine or square waves instantly available at slide switch. All components are of highest quality, cased 110V. 60 cycle power transformer, Mallory F.P. filter condensers, 5 tubes, calibrated 2 color panel, grey crackle aluminum cabinet. The detailed instructions make assembly an interesting and instructive few hours. Shipping Wt., 15 lbs.

## New Heathkit BATTERY ELIMINATOR KIT

Nothing  
ELSE  
TO BUY

**\$22<sup>50</sup>**



Now a bench 6 Volt power supply kit for all auto radio testing. Supplies 5-7 1/2 Volts at 10 Amperes continuous or 15 Amperes intermittent. A well filtered rugged power supply uses heavy duty selenium rectifier, choke input filter with 4,000 MFD of electrolytic filter. 0-15 Volt meter indicates output. Output variable in eight steps. Excellent for demonstrating auto radios. Ideal for servicing — can be lowered to find sticky vibrators or stepped up to equivalent of generator overload — easily constructed in less than two hours. Complete in every respect. Shipping Wt., 18 lbs.

## NEW Heathkit SIGNAL TRACER AND UNIVERSAL TEST SPEAKER KIT

Nothing  
ELSE  
TO BUY

**\$19<sup>50</sup>**

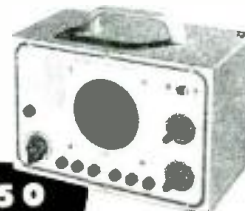

The popular Heathkit signal tracer has now been combined with a universal test speaker at no increase in price. The same high quality tracer follows signal from antenna to speaker — locates intermittents — defective parts quicker — saves valuable service time — gives greater income per service hour. Works equally well on broadcast — FM or TV receivers. The test speaker has assortment of switching ranges to match push pull or single output impedance. Also test microphones, pickups — PA systems — comes complete — cabinet — 110V. 60 cycle power transformer — tubes, test probe, all parts and detailed instructions for assembly and use. Shipping Wt., 8 lbs.

EXPORT DEPT.  
13 East 40th St.  
NEW YORK CITY (16)  
CABLE: ARLAB-NY

The **HEATH COMPANY**

... BENTON HARBOR 20, MICHIGAN

# MORE QUALITY in

## 1950 Heathkits

### The NEW 1950 Heathkit VACUUM TUBE VOLTMETER KIT

#### Features

- New 200 microampere meter.
- Uses 1% precision ceramic divider resistors.
- Burn-out proof meter circuit.
- 24 complete ranges.
- Isolated probe for dynamic testing.
- Most beautiful VTVM in America.
- Accessory probes (extra) extend ranges to 10,000 Volts and 100 Megacycles.
- Modern push-pull electronic voltmeter circuit.
- Electronic AC circuit. No current drawing rectifiers.
- Shatterproof plastic meter face.



**\$24.50**

A new Model V-2 Heathkit VTVM with new 200 microampere meter four additional ranges—full scale linear ranges on both AC and DC of 0.3 V., 10 V., 30 V., 100 V., 300 V., and 1,000 V. Accessory probe listed elsewhere in ad extends voltage range to 3,000 and 10,000 volts D.C. New model has greater sensitivity, stability and accuracy—still the highest quality features—shatterproof plastic full view meter face—automatic meter protection, push-pull electronic voltmeter circuit, linear scales—db scale—ohmmeter measures 1/10 ohm to 1 billion ohms with internal battery—isolated DC test prod for dynamic measurements—11 megohm input resistance on DC—AC uses electronic rectification with 6H6 tube. All these features and still the amazing price of only \$24.50. Comes complete with cabinet—panel—three tubes—new Mallory switches—test prods and leads, 1% ceramic divider resistors and all other parts. Complete instruction manual for assembly and use. Better start your laboratory with this precision instrument. Shipping weight 8 lbs. Model V-2 .....

### New 1950 VERNIER TUNING R.F. Heathkit SIGNAL GENERATOR KIT

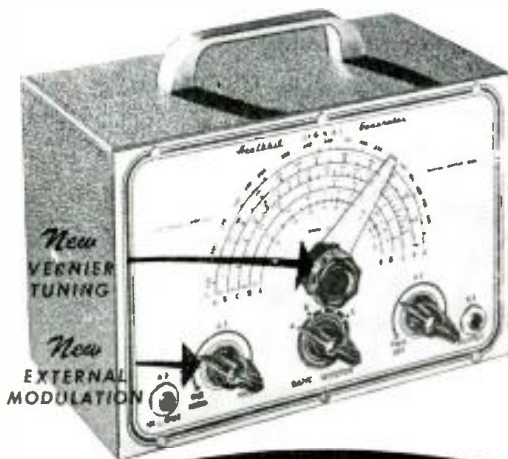

**\$19.50**

#### Features

- New 5 to 1 ratio vernier tuning for ease and accuracy.
- New external modulation switch—use it for fidelity testing.
- New precision coils for greater output.
- Cathode follower output for greatest stability.
- 400 cycle audio available for audio testing.
- Most modern type R.F. oscillator.
- Covers 150Kc. to 34Mc. on fundamentals and calibrated strong harmonics to 102 Mc.

The most popular signal generator kit has been vastly improved—the experience of thousands combined to give you the best. Check the features in this fine generator and consider the low price \$19.50. A best buy for any shop, yet inexpensive enough for hobbyists. Everyone can have an accurate controlled source of R.F. signal voltage.

The new features double the value—think of being able to make fidelity checks on receivers by inserting a variable audio signal. Internal 400 cycle saw-tooth audio oscillator modulates R.F. signal and is available externally for audio testing. The new 5 to 1 ratio vernier drive gives hairline tuning for maximum accuracy in scale settings. The coils are already precision wound and calibrated. Uses turret type coil and switch assembly for ease of construction. The generator is 110 V., 60 cycle transformer operated and comes complete in every detail—cabinet—tubes—coils—beautiful two color calibrated panel and all small parts—new step-by-step pictorial diagrams and complete instruction manual make assembly a cinch even for novices. Why try to get along without a signal generator when you can have the best for less than a twenty dollar bill. Better order it now. Shipping weight 7 lbs. .... \$19.50

#### CONVERSION KIT FOR G-1 GENERATORS

Conversion kit for G-1 generators for vernier tuning and external modulation includes new high band coil for greater output. Gives all the features of new G-5 listed above. Order G-5 Conversion Kit No. 316 ..... \$4.50

EXPORT DEPT.  
13 East 40th St.  
NEW YORK CITY (16)  
CABLE: ARLAB—N.Y.

## The HEATH COMPANY

... BENTON HARBOR 20, MICHIGAN

RADIO-ELECTRONICS for



Order **YOUR HEATHKITS** Now

Enjoy them for years...

*Heathkit*  
**ELECTRONIC SWITCH KIT**

DOUBLES THE UTILITY OF ANY SCOPE

**\$34<sup>50</sup>**

*Nothing ELSE TO BUY*



An electronic switch used with any oscilloscope provides two separately controllable traces on the screen. Each trace is controlled independently and the position of the traces may be varied. The input and output traces of an amplifier may be observed one beside the other or one directly over the other illustrating perfectly any change occurring in the amplifier. Distortion — phase shift and other defects show up instantly. 110V. 60 cycle transformer operated. Uses 5 tubes (1 6X5, 2 6SN7's, 2 6SJ7's). Has individual gain controls, positioning control and coarse and fine sweeping rate controls. The cabinet and panel match all other Heathkits. Every part supplied including detailed instructions for assembly and use. Shipping Wt., 11 lbs.

*New Heathkit*  
**FM TUNER KIT**



CABINET EXTRA **\$14<sup>75</sup>**

A truly fine FM Tuner with the coils ready wound, all alignment completed — all that is necessary is wiring and it's ready to play — uses super regenerative circuit — 110V. 60 cycle transformer operated — two gang tuning condenser — slide rule calibrated dial — two tubes — complete instructions including pictorial enable even beginners to build successfully. Shipping Wt., 4 lbs.

Beautiful mahogany cabinet for FM Tuner (shown above) extra ..... **\$3.75**

*Heathkit*  
**CONDENSER CHECKER KIT**

**\$19<sup>50</sup>**

*Features*

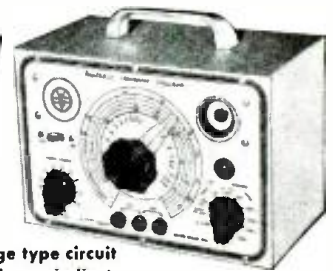

- Power factor scale
- Measures resistance
- Measures leakage
- Checks paper-mica-electrolytics
- Bridge type circuit
- Magic eye indicator
- 110 V. transformer operated
- All scales on panel

Checks all types of condensers, paper-mica-electrolytic-ceramic over a range of .00001 MFD to 1000 MFD. All on readable scales that are read direct from the panel. **NO CHARTS OR MULTIPLIERS NECESSARY.** A condenser checker anyone can read without a college education. A leakage test and polarizing voltage for 20 to 500 volts provided. Measures power factor of electrolytics between 0% and 50%. 110V. 60 cycle transformer operated complete with rectifier and magic eye tubes, cabinet, calibrated panel, test leads and all other parts. Clear detailed instructions for assembly and use. Why guess at the quality and capacity of a condenser when you can know for less than a twenty dollar bill. Shipping Wt., 7 lbs.

*Heathkit*  
**3-TUBE ALL WAVE RADIO KIT**



**\$8<sup>75</sup>**

CABINET EXTRA

An ideal way to learn radio. This kit is complete ready to assemble, with tubes and all other parts. Operates from 110V AC. Simple, clear detailed instructions make this a good radio training course. Covers regular broadcasts and short wave bands. Plug-in coils. Regenerative circuit. Operates loud speaker. Shipping Wt., 3 lbs.

HS30 Headphones per set..... **\$1.00**  
2 1/2" Permanent Magnet Loudspeaker..... **1.95**  
Mahogany Cabinet..... **2.95**

*Heathkit*  
**HIGH FIDELITY AMPLIFIER KIT**

*Nothing ELSE TO BUY*

**\$14<sup>95</sup>**

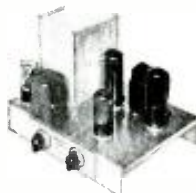

Build this high fidelity amplifier and save two-thirds of the cost. 110V. 60 cy. transformer operated. Push pull output using 1619 tubes (military type 6L6's), two amplifier stages using a dual triode (6SL7), as a phase inverter give this amplifier a linear reproduction equal to amplifiers selling for ten times this price. Every part supplied; punched and formed chassis, transformers (including quality output to 3-8 ohm voice coil), tubes, controls, and complete instructions. Add postage for 20 lbs.

12" PM Speakers for above.... **\$6.95**  
Mahogany Speaker Cabinet, 14 1/2" x 14 1/2" x 8"..... **\$8.75**

**ORDER BLANK**

<b>HEATH CO.</b> BENTON HARBOR MICHIGAN		FROM _____ _____ _____	SHIP VIA ____ Parcel Post ____ Express ____ Freight ____ Best Way	
Quan.	DESCRIPTION	Price	Total	

ENCLOSED FIND  CHECK . . .  MONEY ORDER FOR \_\_\_\_\_  
PLEASE SHIP C.O.D. . . . POSTAGE ENCLOSED FOR \_\_\_\_\_ POUNDS

EXPORT DEPT.  
13 East 40th St.  
NEW YORK CITY (16)  
CABLE: ARLAB-N.Y.

**The HEATH COMPANY**  
... BENTON HARBOR 20, MICHIGAN

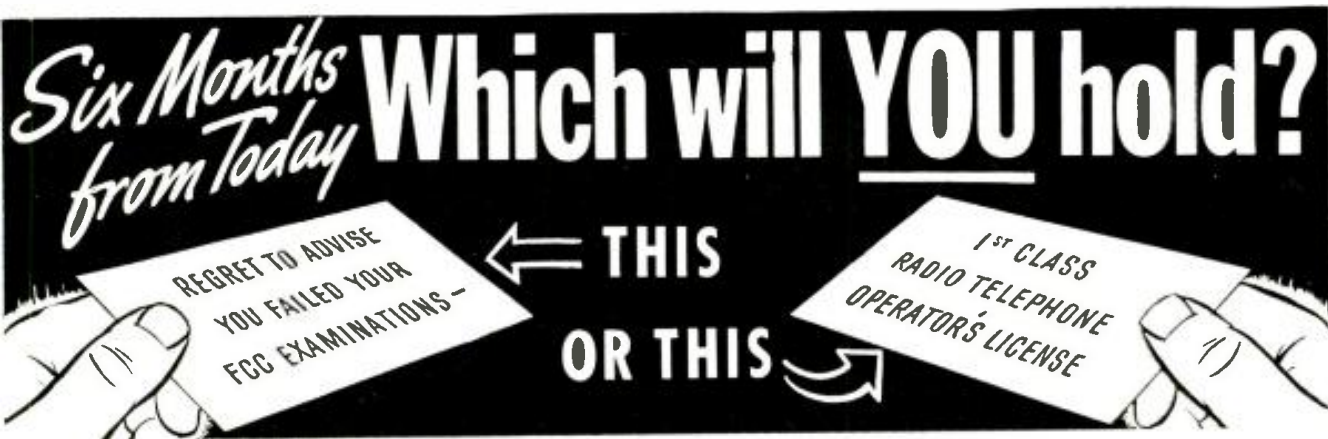

## WANT YOUR FCC COMMERCIAL LICENSE IN A HURRY?

Add Technical Training to Your Practical Experience and Get Your "Ticket" in a FEW SHORT WEEKS  
It's EASY When You Use CIRE Simplified Training and Coaching AT HOME in SPARE TIME

Thousands of new jobs are opening up—FM, Television, Mobile Communication Systems. These are only a few of the radio fields which require licensed radio technicians and operators. Get your license without delay. Let Cleveland Institute prepare you to pass

FCC license examinations, and hold the jobs which a license entitles you to, with CIRE streamlined, post-war methods of coaching and training.

### Your FCC Ticket is Always Recognized in ALL Radio Fields as Proof of Your Technical Ability

More than ever before an FCC Commercial Operator License is a sure passport to many of the better paying jobs in this New World of Electronics. Employers always give preference to the license

holder, even though a license is not required for the job. Hold an FCC "ticket" and the job is yours!

#### CIRE Job-Finding Service Brings Amazing Offers of Jobs!

"Have found and accepted a position at KWAD in Wadena, Minn. I am indebted to CIRE for I secured this position through the help of the CIRE Job Finding Service. I had six other offers from stations receiving my employment application and CIRE reference. I am sincerely under obligation to you."  
Student No. 2760 AT

"I am working at WRJM as transmitter engineer, and I received this position in response to one of the employment applications sent me upon completion of my course and the receiving of my Diploma. I received my 1st class Radiotelephone License on March 2, 1949. I want to express my sincere appreciation to the staff of CIRE."  
Student No. 2608 AT

"Thanks for the Application for Employment you recently prepared for me. I found satisfactory employment. I submitted 57 letters, enclosing the resume you supplied. I received 17 letters indicating my application was filed for future reference; 3 telephone calls, and one letter requesting personal interviews. As a result, I am employed in a development engineering capacity."  
Student No. 4235 NB

"I now hold ticket Number P-10-3787, and holding the license has helped me to obtain the type of job I've always dreamed of having. Yes, thanks to CIRE, I am now working for CAA as Radio Maintenance Technician, at a far better salary than I've ever had before. I am deeply grateful."  
Student No. 3319N12

### Look At The Job Opportunities You Will Have When You Get Your FCC Ticket!

- Forestry and conservation
- Ambulances and hospitals
- Gas and electric utilities
- Gas and oil pipe lines
- Private automobiles
- Street railways
- Taxicab fleets
- Bus and truck fleets
- Police and fire depts.
- Telephone companies
- Merchant marine
- Highway Patrol
- Railroads
- Airlines

### LOOK AT THESE AVERAGE PAY SCHEDULES FOR BROADCAST JOBS (Reported by FCC Nationwide Survey)

Position	Big Stations	Little Stations
Transmitter Engineer	\$4800	\$3000
Studio Engineer	5000	3650
Chief Engineer	7700	4300

Other jobs requiring FCC commercial licenses pay similar salaries.

## Get this AMAZING NEW BOOKLET

1. Tells of Thousands of Brand-New Better Paying Radio Jobs Now Open to FCC License Holders.

2. Tells How We Guarantee to Train and Coach You Until You Get Your FCC license.

3. Tells How Our Amazing Job-FINDING Service Helps You Get The Better Paying Radio Job Our Training Prepares You To Hold.

Mail Coupon At Once  
**GET ALL 3 FREE**

Approved for Veteran Training under "G. I. Bill of Rights"

CLEVELAND INSTITUTE OF RADIO ELECTRONICS (Address to Desk No. to avoid delay)  
Desk RE-9 4900 Euclid Bldg., Cleveland 3, Ohio

I want to know how I can get my FCC ticket in a few short weeks by training at home in spare time. Send me your amazing new FREE booklet "Money Making FCC License Information", as well as a FREE sample FCC-type exam and FREE booklet "How to Pass FCC License Examinations (does not cover exams for amateur license).

Name \_\_\_\_\_  
Address \_\_\_\_\_  
City \_\_\_\_\_ Zone \_\_\_\_\_ State \_\_\_\_\_  
 Veterans check for enrollment information under G. I. Bill  NO OBLIGATION—NO SALESMEN

RADIO-ELECTRONICS for



# How to Get Into Radio

*. . . The radio-electronic field needs more good men than ever before . . .*

By HUGO GERNSBACH

**T**HIS is the time of the year when young graduates write to editors for advice on getting a position.

These career-minded young people, as a rule, have had good grades and are anxious to enter their chosen field.

Hardly ever do they have any practical experience, hence their inquiring letters, of which we receive many during the early part of every summer. Here is a sample:

*Dear Editor:*

About a year ago I became very interested in audio equipment and its design. However, because of my very limited experience I have been unable to obtain a position in this field. I attended a Midwest technical institute for one and one-half years and was graduated recently. I believe that I made a good record there as far as scholastic achievement is concerned. What I would like to know is how to go about approaching a manufacturer and getting him interested in my abilities. That is the big problem; most companies are afraid to try anyone who does not have a maximum of experience.

FRANK B. BURNS

*Forest Park, Illinois*

We have, in past editorials, broached this subject, which keeps recurring from time to time.\*

The answer is not too difficult, though it is not simple. We have a favorite recommendation to make, and it has in the past brought good results for many.

Employers are always busy and often hardboiled, particularly when it comes to inexperienced graduates. An applicant should know first of all that his remuneration cannot be very high so long as he is a beginner. He should realize that if he is fortunate enough to get into a firm, he will probably represent a loss for several months, during which time he has to learn. If the applicant has real aptitude that loss may be slight—one of a few days' orientation. But that loss may be a total one—of both time and wages—if the firm decides that the new employe cannot make the grade.

In other words, as an apprentice, the recent graduate should be willing to take anything that he can get during that period, keeping the long view in mind. This is one of the important considerations that must always be remembered.

Now, in trying to get a hearing either in person or

by mail, submitting an ordinary application is usually valueless. Most employers routinely get hundreds of these. They are rarely considered seriously unless the employment manager has a lot of time on his hands, which few have.

The inexperienced applicant, therefore, must take other means to get attention. One of the best ways to get it is to learn all about the products of the manufacturer he wants to go with.

Suppose you want to get a position with the XYZ Radio Corporation. First send for their literature, particularly on the subject that you know most about. If you are interested in audio as is our correspondent, one lead might be a speaker manufacturer. After reading all the manufacturer's literature, it would be an excellent idea to write a special thesis composed, not in form of an ordinary letter, but as a well typed manuscript, neatly stapled together like a legal document. Put all the thoughts you have on the manufacturer's product into this manuscript—and do not be afraid—if the case warrants it—to criticize if you feel that it could be improved.

Put all your best thoughts and ideas into this presentation. After you have finished, rewrite it one or more times to be sure that it is letter-perfect. Then sign it with your name and address and send it by first-class mail to one of the officials of the corporation.

You should, at the end of the manuscript, state in a few words that you are available for employment and would like an interview.

A presentation of this type is almost certain to get an answer. *It may however not get you a job immediately.* You may have to try this routine on half a dozen or more manufacturers before you succeed. But in the end you are certain to get somewhere because every wide-awake manufacturer is always looking for men of ability and ingenuity.

Furthermore even if there is no opening at the time, the manufacturer—if impressed with your presentation—will probably keep it on file and communicate with you later, if a vacancy occurs.

Remember: the more validly interesting, the more striking you can make your original application, the more certain you are to get a favorable hearing.

The interesting feature of this method is that it costs nothing except your time. Even this will not be wasted for the simple reason that the more of these applications you make, the more knowledge you acquire about the field in which you are interested.

Many who have tried the system have found that it pays excellent dividends.

\* See editorial "Radio As a Vocation", April, 1948.

# Prospecting for URANIUM



Description of a G-M counter suitable for detecting ores containing radioactive metal

By ROBERT F. SCOTT

**U**RANIUM, discovered in 1789 by the German scientist Martin H. Klaproth and named for the planet Uranus, was hardly more than a scientific curiosity until 1902 when the Curies extracted radium from pitchblende, which also contains uranium. Since this time, deposits of uranium-bearing ores have been found in almost every country in the world and in most of the United States. Unfortunately, most of the deposits are very small or contain such low-grade ores as to make mining unprofitable. Prior to the war, some of them were worked as sources of radium and of uranium for use primarily in such industrial applications as hardening steel.

In the postwar atomic age, uranium and other radioactive minerals have attained a new high in value. So much so, in fact, that the Atomic Energy Commission has offered a \$10,000 bonus for the discovery of a new deposit and production therefrom of at least 20 tons of ore assaying 20% or more of uranium oxide. Furthermore, they guarantee \$3.50 per pound for delivery of high-grade uranium ores.

Unlike many minerals, uranium-bearing ores are not easily recognizable by sight. Radioactive minerals may be detected in a number of ways, the most

effective of which is through the use of a Geiger-Muller counter.

Prior to the war, G-M counters were large, expensive instruments seldom seen outside of a few laboratories. During the war, lightweight portable counters were developed for atomic research and uranium prospecting. Typical of these is the Forty-Niner, a development of the Forty-Niner Corporation, of Detroit, Mich.

This counter uses a standard circuit consisting of a G-M counter tube, amplifier, and high-voltage supply. The counter tube is housed in the end of a 3-foot probe equipped with a 4-foot extension cord. This construction enables the operator to explore crevices or the surface of the earth from a comfortable position. The power supply and amplifier are in a 4 x 5 x 6-inch metal box weighing 4½ pounds complete with three standard 1½-volt flashlight cells and two small 67½-volt batteries.

Radioactive materials are detected by listening for an increase in the number of clicks heard in headphones or the speaker supplied with the counter. This speaker consists of a single 1,000-ohm headphone mounted in a small metal case that clamps over a shoulder strap. Standard headphones provide a louder

signal and may prove more convenient to use under some conditions.

The circuit of the Forty-Niner is shown in the diagram. The counter tube, a Victoreen type 1B85, is capacitively coupled to a 1T4 pulse amplifier that drives the headphones or speaker. The operation of this section of the circuit was covered in the article "Prospecting for Uranium Ores Using G-M Counters," in the July, 1949, issue of RADIO-ELECTRONICS.

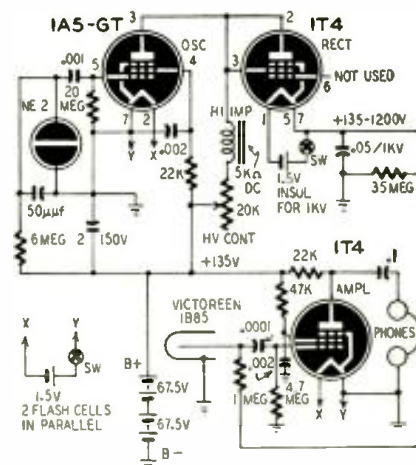

Forty-Niner, the complete schematic diagram  
RADIO-ELECTRONICS for



The high-voltage supply for the counter tube consists of a 5,000-cycle relaxation oscillator using a neon lamp, a 1A5 pulse amplifier, and a 1T4 high-voltage rectifier. The output of this oscillator is differentiated and amplified by the 1A5. The amplified pulses are taken from the plate of this tube and rectified by the 1T4 rectifier. The voltage is taken from the filament of the 1T4 and filtered by the .05- $\mu$ f capacitor and the 35-megohm resistor.

The output voltage may be varied between 150 and 1,200 volts by adjusting the high-voltage control. The voltage should be adjusted to approximately 800 volts for proper operation of the 1B85. This condition is met by adjusting the control for a background count of about 45 clicks per minute. The voltage control permits the operator to adjust the instrument for proper operation even after the B-batteries have aged considerably.

The Forty-Niner uses two small 67.5-volt B-batteries and three standard 1.5-volt flashlight cells. Both kinds of batteries are commonly used in personal-type radios and are readily available in most small communities and trading posts. All other components, except the

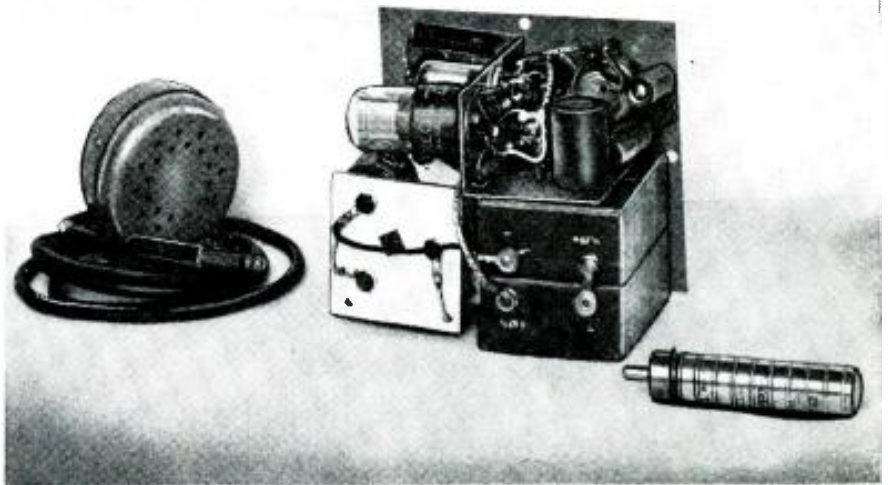

The Forty-Niner disassembled, showing power supply-amplifier, shoulder speaker, G-M tube.

1B85 and high-voltage coil can be replaced at most radio service shops.

A high-pitched whistle can be heard in the phones when the counter is in use. This whistle, probably caused by

feedback in the 1A5 amplifier and having no particular function in the counter, can be removed by shunting a .01- $\mu$ f capacitor across the phone jack if it proves annoying to the operator.

# Information For Prospectors

## List of assay stations to which you may send ore samples and a bibliography of prospecting data

### Uranium Assay Stations

Prospectors for uranium seldom have the facilities or knowledge for evaluating the qualities of supposed ore deposit: themselves, so must send samples of the mineral to assay stations for tests. Listed below are 12 places designated by the Atomic Energy Commission which will assay your samples free of charge.

A sample of rock securely wrapped, clearly labeled, and fairly representing the entire deposit, should be shipped to the nearest of these stations. Samples should weigh at least 1, and not more than 10, pounds.

It is not advisable to send large numbers of specimens on mere speculation; unnecessarily overburdening the testing stations, will delay reports on everybody's samples. Reliable radiation-counter test or equally satisfactory evidence should determine the prospector's decision to send his sample. Results are sent only to the person submitting the sample.

Questions are frequently asked, incidentally, about a possible danger to health in uranium deposit areas. The AEC states explicitly that uranium mining is no more dangerous than mining other minerals unless a rock bearing a high concentration of uranium is held against the body for a

very long time. In deposits discovered thus far, the concentration of radioactive substance is never high enough to create danger of radiation sickness.

U. S. Geological Survey  
Geochemistry & Petrology Branch  
Building 213, Naval Gun Factory  
Washington, D. C.

Chief, College Park Branch  
Metallurgical Division  
U. S. Bureau of Mines  
College Park, Maryland

Chief, Rolla Branch  
Metallurgical Division  
U. S. Bureau of Mines  
Rolla, Missouri

Chief, Salt Lake City Branch  
Metallurgical Division  
U. S. Bureau of Mines  
Salt Lake City, Utah

Division of Natural Resources,  
Department of Agriculture,  
County of San Diego  
4005 Rosecrans Street  
San Diego 10, California

Idaho Bureau of Mines & Geology  
Moscow, Idaho

Chief, Albany Branch  
Metallurgical Division  
U. S. Bureau of Mines  
Albany, Oregon

Chief, Tuscaloosa Branch  
Metallurgical Division  
U. S. Bureau of Mines  
Tuscaloosa, Alabama

Chief, Tucson Branch  
Metallurgical Division  
U. S. Bureau of Mines  
Tucson, Arizona

Nevada State Analytical Laboratory  
University of Nevada  
Reno, Nevada

Note: This agency will test samples from the State of Nevada only.

Supervising Engineer  
Metallurgical Division  
U. S. Bureau of Mines  
Reno, Nevada

Montana Bureau of Mines and  
Geology  
Butte, Montana

### Books For Uranium Prospectors

HANDBOOK OF URANIUM MINERALS, by Jack Dement and H. C. Drake. (Mineralogist Publishing Co., Portland 15, Oregon).....\$2.00

YOU CAN FIND URANIUM, by Joseph L. Weiss and W. R. Orlandi. (J. B. Weiland & Co., San Francisco 26, Calif.) .....\$2.00

PROSPECTING FOR URANIUM (U. S. Atomic Energy Commission and U. S. Geological Survey). For sale by Supt. of Documents, U. S. Government Printing Office, Washington 25, D. C. ....30c

RADIOACTIVE URANIUM AND THORIUM, compiled by John W. Anthony. (Arizona Bureau of Mines, University of Arizona, Tucson, Arizona.) .....25c

PROSPECTORS' GUIDE FOR URANIUM AND THORIUM MINERALS IN CANADA. (Mines, Forests and Scientific Services Branch, Bureau of Mines, Department of Mines and Resources, Ottawa, Canada) .....gratis

TABLES OF FLUORESCENT AND RADIOACTIVE MINERALS, compiled by Robert L. Hershey. (New Mexico Bureau of Mines and Mineral Resources, Socorro, N. M.) .....gratis

A GUIDE TO URANIUM PROSPECTORS IN MICHIGAN, by B. E. Kennedy. (Michigan Department of Conservation, Geological Survey Division, Lansing 13, Mich.) .....gratis to residents of State, 50c to nonresidents.

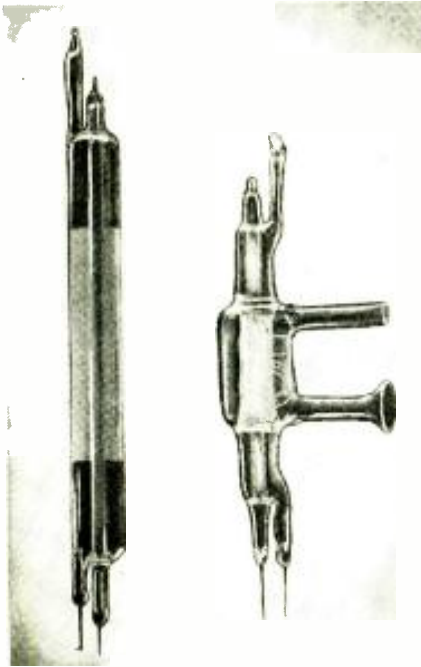

Courtesy N. Wood Counter Laboratory

A pair of laboratory-type Geiger-Muller tubes.

**A** GAIN a new tube has appeared on the radioman's horizon. Called the Geiger counter or Geiger-Mueller tube, it is not strictly new, any more than the cathode-ray tube which was popularized by television. The cathode-ray tube was old when the triode was invented; and the Geiger counter was originated about the same time as the cathode-ray tube—in 1908. But it took the atomic age and the demand for uranium to bring it into mass production and onto the service technician's bench. Radiation detection today is an important subject not only for scientists, but for students and prospectors as well.

But what is radiation detection? And what does a radiation detector do? We all know vaguely and confusedly what radiation is. We use indiscriminate terms when talking about it. For instance, we speak of cathode rays and light rays as if they were the same thing. But cathode rays are streams of electrons—fine particles of electricity, or matter if you like. Light rays, on the contrary, are electromagnetic waves, and as far as we know contain no particles of anything.

The rays we are talking about in this article are those emitted by the top-heavy and unstable atoms of such heavy mineral elements as uranium, thorium, and radium. These elements are continually breaking down and changing into other kinds of matter. In the process, certain parts of the original atom are not only not used; are in fact expelled with almost unbelievable force. These "rays" are of three kinds: alpha, beta, and gamma (A, B, and C to a Greek).

The alpha ray is exactly the same thing as the nucleus of a helium atom. The beta ray is simply our old friend the electron, disguised under a Greek

# The Geiger Counter

## How Does it Work?

Anyone with an understanding of radio circuits can grasp the fundamentals of counters

By ERIC LESLIE

name. And the gamma ray is an X-ray (a very shortwave, powerful one).

The three rays come out of their atoms with a few million volts of energy behind them and speed through the air or other material ahead until they are stopped by collisions with atoms in their paths. The heavy alpha rays have the shortest range—3 or 4



Fig. 1—G-M tube output is a series of pulses.

inches in ordinary air. The lighter beta rays get a little farther, but it is the gamma ray which is the dx addict of the nucleonic world. Gamma rays from uranium have been detected through 50 feet of rock, though equally strong rays have been cut off by 3 feet of a particular kind of earth.

It is their slowing down and being stopped by collisions with bits of matter (atoms of the air's gases, for example) that give us a chance to detect them. That's where the Geiger counter comes in.

### What is a Geiger counter?

When a ray hits an atom of gas head on, it is likely to *ionize* it (knock an electron loose, and thus break it up). Normally the negative electron and positive ion would drift back together again, and the atom would reform. But if the atom is in a space between two highly charged electrodes, the electron is attracted toward the positive electrode and the positive ion toward the negative one. A Geiger counter is just such a pair of charged electrodes.

In its simplest form, the negative electrode is a cylinder and the positive

electrode is a wire running down its center. The whole is sealed in a glass cylinder, evacuated, and a certain amount of gas inserted. This is the form in which it was invented by Geiger and Rutherford in 1908, and the original arrangement is recognizable in the accompanying photographs of modern counters. When a ray breaks up some of the atoms of gas in the tube, the negative electrons move to the positively charged central wire and the positive ions drift more slowly to the negative outside cylinder, where they find free electrons and become atoms again.

This process is equivalent to a minute flow through the tube, and, by using a resistor in series, we can use this flow to produce a voltage drop at the grid of a tube (Fig. 1). Any radioman can go on from here. Some of the tubes have a large "window" at the end, which gives them a different appearance, but the principle is the same.

So that's all there is to a Geiger counter. In fact, it's more. The counter doesn't need to be a cylinder and wire—M.I.T. shows visitors a fork and spoon hung in a partially exhausted chamber. The combination counts beautifully. Even the partial vacuum and gas content is not always necessary. Some counters work in air, and others in gases at pressures greater than atmospheric. All are for specialized applications, of course.

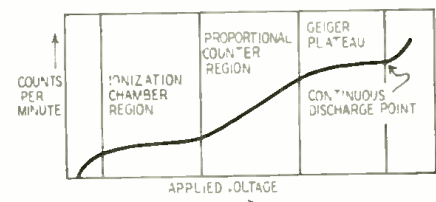

Fig. 2—Anode voltage sets mode of operation.

RADIO-ELECTRONICS for



Some radiomen have wondered if they mightn't even find an old receiving tube or two in the junkbox that would function as a Geiger counter. We wouldn't like to bet—either way! Quite possibly a gassy 80 might act—given the right voltages—as a pretty fair counter. And how about the old 45's? Some people used to insist that they make usable phototubes.

The easy way to get a Geiger counter that you *know* will work is to buy one. It will contain the right amount of the right kind of gas, and you will know beforehand how much voltage to put on it.

For—like a lot of other apparently simple things—the Geiger counter isn't actually simple! For example, we can, by changing the voltage on it, make the same tube act as three different instruments: an *ionization chamber*, a *proportional counter*, and a true Geiger-Mueller tube.



The Nuclear Instrument & Chemical Corp. D11.

**The Geiger plateau**

Suppose, starting with a counter, some radioactive material (a luminous watch dial), and a variable voltage supply, we note the number of counts per minute as the voltage is increased.

Nothing happens till we reach a certain voltage (determined by the size of the tube, the gas it contains and other factors, but usually around 300 in commercial models). The tube starts counting. (See Fig. 2.) Below this voltage the electric field was not strong enough to attract to the center wire the electrons freed by ray collision. Now they are going to the center wire, where enough of them will produce a negative pulse that can be detected. What we have at this point is an ionization chamber. It is used mostly to detect alpha particles, which produce large numbers of ions during their short run. Beta or gamma rays would seldom release enough electrons to register a pulse.

As the voltage is raised further, we get an increasing number of counts. Electrons released by ray collisions are moving toward the center wire with enough speed to knock off *other* electrons and increase the ionization. The number of electrons is no longer the number knocked loose by the ray, but a multiple of it. Because the size of the negative pulses on the center wire is thus proportional to the number of collisions, this range of voltages is

called the *proportional region* and a tube working in it a proportional counter.

As we continue to raise the voltage we reach a point at which an increase does not cause an advance in the number of counts. This is the *Geiger region*. It is believed that within this range of voltages the atoms are in such a critical state of strain that knocking a single electron off one of them will start a whole chain reaction of collisions, so that the number of electrons which reach the central wire is about the same if the ray releases one electron or ten thousand. This *Townsend avalanche*, named after the man who first explained it, is the reason for the great sensitivity of the Geiger counter. A single collision may produce a count.

The range of voltages over which true Geiger action takes place is the *Geiger plateau*, or simply the plateau. If we raise the voltage further, the tube just conducts continuously. It has passed its *striking voltage*.

**Quenching action**

Geiger counters are described as self-quenching or nonself-quenching, depending on whether or not they de-ionize and become ready for the next count without outside help. The nonself-quenching tube is filled with a simple gas made of one kind of atoms, such as argon or neon. On each count, as the electrons rush toward the center wire, the heavier positive ions move more slowly toward the negative cylinder. Their collisions with the cylinder (and a series of other complicated actions) may dislodge secondary

A quicker method is to use a circuit which puts a sharp negative pulse on the positive center wire immediately after each count. Such a circuit is shown in Fig. 3, part of a portable counter schematic printed in this magazine August, 1948, page 64. The pulse from the counter goes to the grid of triode V1-b, is amplified and passed to another stage for further amplification. But the output of V1-b is also coupled back to the grid of V1-a in a multivibrator circuit, so as to produce a strong negative pulse in the plate circuit of V1-a, which is also coupled to the center wire of the counter. The negative pulse drives the center wire negative enough to quench the discharge, and the tube is ready for action again.

A tube can be made *self-quenching* by putting in it a small amount of some more complex gas, such as acetylene, chloroform, or ammonia. This slows the ions to such an extent that secondary electrons are not produced. (It's really not as simple as that, but that is the end result.) About 10% (by volume) of alcohol vapor added to the gas makes a tube quench automatically, although other mixtures can be and are used.

Both types of counters have their advantages and disadvantages. A self-quenching tube needs no special circuits, and is better adapted to light portable equipment. On the other hand, the very action of quenching "wears out" the heavy gases, breaking them down into simpler ones that will not quench. Thus a self-quenching tube has a definite life span, usually measured in millions of counts, while the nonself-quenching type lasts indefinitely.

**Other distinctions**

Tubes are also known as alpha-, beta-, or gamma-ray detectors. Since alpha rays are so commonly detected with ionization chambers, we hear more about beta and gamma rays in connection with Geiger counters. The difference is in the "window" through which the rays get into the tube. The gamma ray is more penetrating than any other type, and is not particularly interested in the material from which the tube is made. The beta ray being more easily discouraged, counters for beta rays

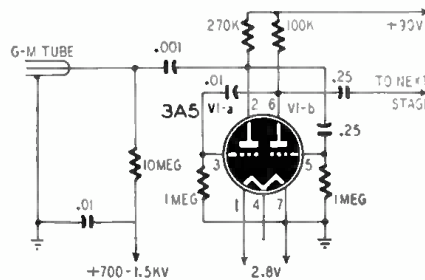

Fig. 3—Tube is quenched by a negative pulse.

electrons from it, which starts the discharge up again, so the tube continues to pass current.

A nonself-quenching tube can be quenched by putting a very high resistance in series with the supply lead. As soon as a discharge starts current flow, the drop across the resistor lowers the voltage between wire and cylinder to a point where ions cease to travel, or drift so slowly as not to kick loose any other electrons.

The disadvantage of this method is that the very high resistance needed (100 megohms has been used) makes the counter's time constant very long. If another ray arrives during the long recovery time, the tube will not be able to count it. This period of insensitivity is called *dead time*.



Tracerlab tubes with removable beta shields.

# Build This Geiger Counter

**No 300-volt batteries are used in this instrument. Cost of constructing it is small**

**By FRED SHUNAMAN  
AND CARL KIEHL**

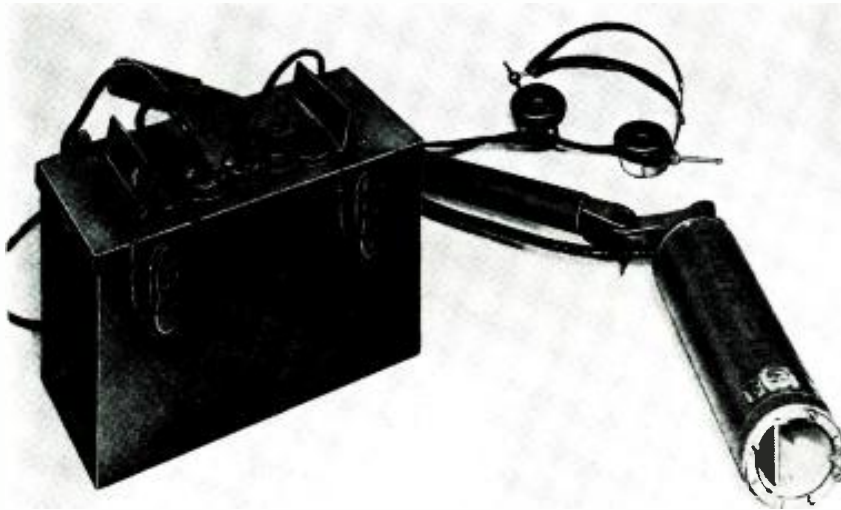

This radiation detector is built in a war surplus case and powered by low-voltage batteries.

**W**E—and several of our friends—had long desired to build an electronic uranium prospecting device, and that ambition was fired by the article "Prospecting for Uranium Ore" in the July issue. The desire was heavily damped by the cost of the trio of 300-volt batteries which seem to be required in all published descriptions of Geiger counters. The rest of the

equipment—including the Geiger tube itself—can be bought for considerably less than the high-voltage batteries alone. We decided that our prospector must have a cheaper voltage supply.

Several types suggest themselves. The batteries would have had the great advantage of simplicity. Just put 'em in and start up. That is, if you feel like putting up \$33 every time you need a new set, which under prospect-

## THE GEIGER COUNTER—HOW DOES IT WORK?

(Continued from previous page)

have very thin windows of glass or mica, usually at the end of the tube. These count gamma rays as well, of course; if it is necessary to find the number of beta rays, the tube can be operated for a definite time with a beta-ray shutter (thin piece of aluminum) over the window, then for the same length of time without it. Any increase in number of counts will be due to beta rays. (Subtract the first count from the second for total beta-ray count.)

### Other differences

Geiger counters vary in a number of other ways. Tubes with special gas mixtures are made to detect special types of particles. Other than those mentioned, protons, photoelectrons, photons, and neutrons are possibly the most important particles detected by the counter.

Sensitivity increases with the diameter of the tube, but so does the voltage required to make it operate. The pressure (vacuum) and the gas used may

also have some effect on the operating voltage.

The Geiger counter is not the only type of ray detector; scientists would probably not even consider it the most important one. But it is the only one that interprets the individual ray track into language that can be understood by an electronic amplifier. As such it is the one most interesting to the electronic technician.



Nucleonic Corp. of America type GM-1W tube.

ing conditions would likely be more often than theory would indicate. And they make a heavy pack.

A vibrator pack is cheap, rugged and long-lived. But it is heavy, like the batteries, and as yet no parts designed for Geiger counter use are generally available. An r.f. pack would probably work, but again, no coils nor exact data are available. Other types of supplies have been suggested, including multivibrators, relaxation circuits (*Electronics*, December, 1943) and Ford coils (*The Review of Scientific Instruments*, December, 1937). Some of them show great promise, but considerable experimental work would be needed to make them usable in a practical portable circuit. We decided on a vibrator unit, especially as we found that a readily available photoflash transformer could be used with it.

The Geiger tube was another item hard to get on short notice. Apparently they are being sold faster than they are being made! The one obtained was an Amperex 151-N. It is a small tube, not as sensitive as some of the big jobs, but has the advantage of requiring a lower voltage. The one we have has a plateau from 500 to 800 volts, though it seems to work better toward the 800-volt end. The whole equipment was designed, however, with the idea of making it usable with any standard Geiger tube.

An old AN/PRS-1 mine detector supplied an excellent case for the power supply and one for the detector head, as well as a handle. The connector cable was discarded in favor of a new one (Geiger counters use anywhere up to 1100 volts) but the old connectors were used. The split rings that hold the plug and receptacle in place were carefully pried out and new wires soldered into place.

The little transmitter was removed from the head, and a piece of Lucite fastened over it, as shown in the photograph. Through the Lucite is seen the chassis, a flat piece of aluminum with turned-up edges, and just the tip of the Geiger tube. The watertight fittings on the battery box were considered valuable, and though a new switch, potentiometer, and cable were installed, the fittings were preserved carefully.

RADIO-ELECTRONICS for



**The vibrator pack**

The power supply (Fig. 1) is of the vibrator type, using a 2-volt portable-radio storage cell, now available at 95¢ and up from surplus houses. Due to difficulty in getting a vibrator quickly, one from an old G-E LB-530-X portable radio was used. It is synchronous and has seven prongs, thus accounting for the peculiar socket numbering. Several 2-volt vibrators are manufactured; it will be easier and cheaper to buy a non-synchronous type.

The U.T.C. photoflash transformer was built to deliver 2,200 volts from 4 or 6 volts, and has 4- and 6-volt taps. With the 2-volt vibrator across the entire 6-volt winding, something over 700 volts d.c. (depending on the bleeder) is obtained. Putting the vibrator across the 4-volt taps raises the d.c. voltage to near 1,000. Thus this power pack can be used for most types of Geiger tubes.

Rectification was a serious problem. An 0Z4 was tried first, but voltage drop across it was too great. Apparently it requires a certain current density to become effective. An ordinary 3Q5—with its filament well insulated from ground—was then tried and gave excellent results. It was operated with the screen tied to the plate and the control grid floating. Later we found that a tube with one side of the filament cut out worked equally well, at a saving of half the filament current, which is well worth while.

Filtering was not difficult. A .02- $\mu$ f, 1,600-volt capacitor was placed across the whole bleeder, acting as the input filter capacitor. Another was connected between output and ground. Since the bleeder consists of a potentiometer and resistor in series, with the output taken from the arm, that part of the potentiometer which is between the moving arm and high voltage becomes the series resistance element in the filter. The system was effective, reducing ripple to a low level. Later addition of a 1- $\mu$ f, 1,000-volt, oil-filled capacitor (fastened to the back of the chassis) brought the ripple down almost to inaudibility. This refinement, while pleasant, was not necessary, for the low original ripple interfered very little with the sharp clicks which indicate radiation.

Strong r.f. hash persisted till the battery input filter was added. This is the coil and pair of capacitors shown at the right of the chassis in the rear-chassis view. The coil was wound of 18 turns of ordinary hookup wire on a lead pencil, then slipped off the pencil and soldered to a convenient pair of lugs on a terminal strip. Neither wire size nor number of turns is in any way critical. The 0.5- $\mu$ f capacitors are of the type used in car radios. It was necessary to shield the choke from other wiring by mounting it outside the chassis, with a *very short lead* running through to the vibrator terminal. This lead can be seen between the farther capacitor and the vibrator. Note that the hole through which it runs was

drilled as close as possible to the terminal to which it runs.

Some of the ripple returned when the set was put into its box, indicating that the choke was radiating to the battery leads. The ideal arrangement would be to enclose both filter and vibrator in a shielded can.

Exact voltages will always depend to some extent on the individual transformer (and vibrator), and bleeder constants will have to be set by experiment. We set the potentiometer near its middle position and juggled fixed resistors till the Geiger tube was receiving 650 volts, putting it at the center of its plateau. Other voltages are needed, of course, for other tubes.

The power supply was mounted on an L-shaped chassis of aluminum, cut to fit on the two uprights that held the AN/PRS-1 amplifier. Other pieces of

piece of Lucite, below the first, insulates live connections from ground. There is high voltage across the blocking capacitor between the G-M tube's anode and the grid of the amplifier tube, so it was made of two small ceramic 100- $\mu$ f units in series.

The two leads to the tube are sleeved in spaghetti and brought through the small sub-chassis on which the 1U5 is mounted.

The amplifier hookup requires no comment, except for the part played by the diode.

It produces regeneration and increases sensitivity. When a negative pulse from the counter reaches the tube grid, the amplified pulse in the plate circuit is immediately impressed on the diode through the coupling capacitor. Electrons drawn by the diode have to get to ground through the grid resistor,

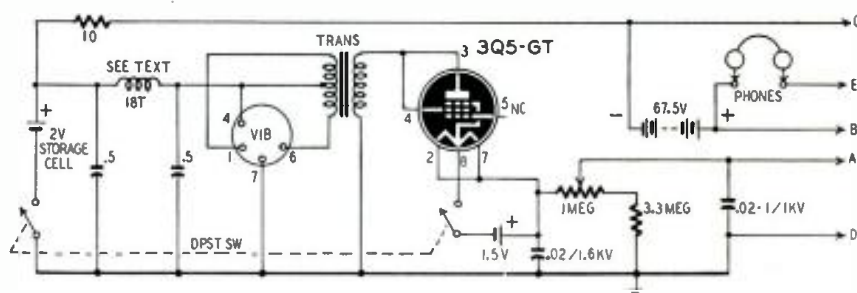

Fig. 1—This is the schematic diagram of the power-supply components inside the main case.

metal were broken off. A new double-pole, single-throw switch was mounted in place of the old one, and the potentiometer was likewise replaced with a 1-megohm unit. The old phone lead was used, and a new cable put in, using the watertight feedthroughs and switch cover of the old instrument.

**The search head**

The head consists of the Geiger tube and a 1-stage amplifier (Fig. 2). The tube is electrically and mechanically connected with a pair of fuse clips mounted on a piece of Lucite. A second

causing a voltage drop across it that drives the grid still more negative. All this happens while the plate current is still going down, and causes a greater dip in it and a sharper click in the headphones.

The plate-diode coupling capacitor is a trimmer from an old i.f. transformer; exact capacitance is unimportant.

The 1U5 filament is operated through a 10-ohm resistor from the 2-volt storage cell. The resistor is installed in the power-supply compartment. B-supply to the plate and screen comes from the 67.5-volt Minimax, also in the power-

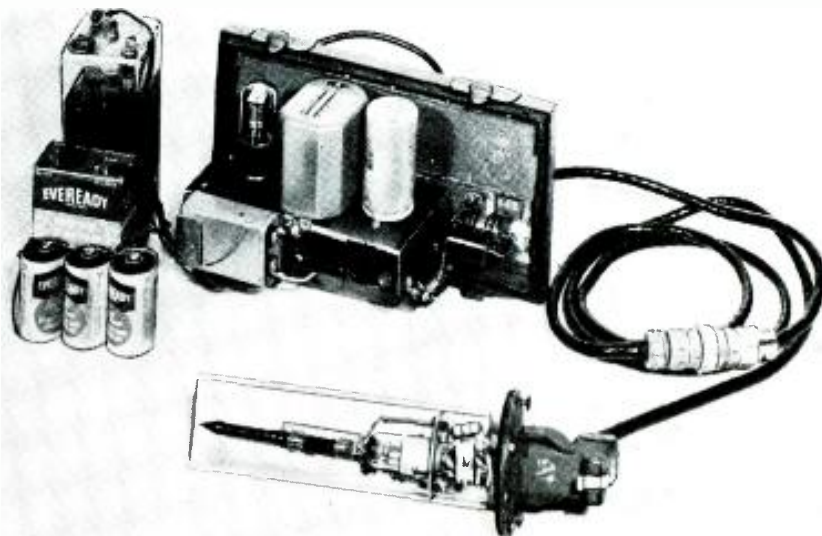

Photograph of complete instrument disassembled shows inside of probe and top of chassis.

supply compartment. Screen voltage is dropped through a 470,000-ohm resistor, which like the two 5.1-megohm resistors used as grid leak and diode resistor and that of 4.7 megohms in the counter's positive lead, are all 1/2-watt units.

The parts for the head were mounted on a piece of aluminum just wide enough to extend across the lower third of the cylinder, thus being supported on its rim. This chassis was held in place with two bolts put through two holes drilled in the aluminum casting which held the original chassis. It was neces-

sary to saw this casting level; however it is unnecessary to give details, as there is no particular reason for building the head into a mine detector unless one happens to be readily available. In fact, the most intriguing head would be one built in the form of a small cylinder, that could be slipped inside of a piece of light 1-inch aluminum pipe.

**The results**

The equipment was taken out for a day's prospecting trip in Magnet Cove,

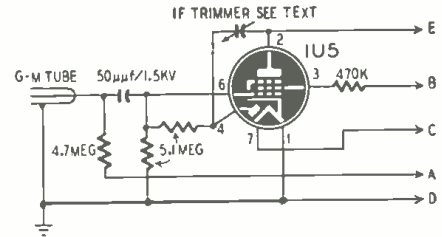
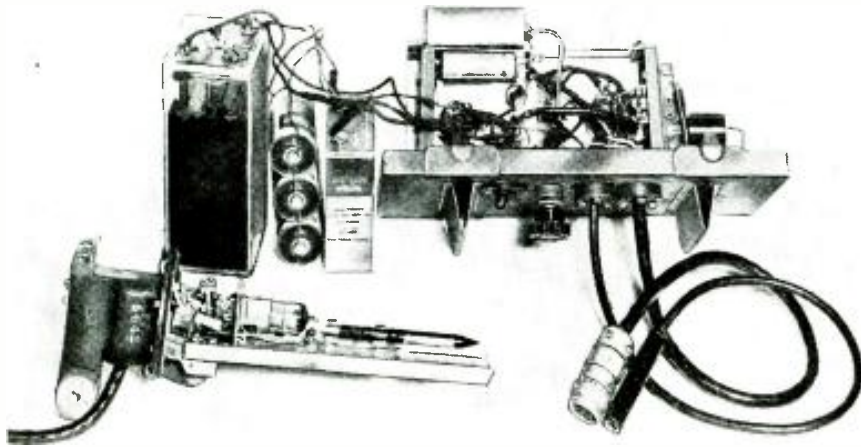

Fig. 2—G-M tube and amplifier are in probe.

Arkansas. This area is a sort of natural mineralogical museum where anything may be expected. No uranium was discovered on that trip or on later ones to other interesting-looking spots. Checked with a small quantity of watch-paint compound, the instrument reacts very decisively. Its normal background (cosmic-ray) count of 5 to 7 per minute goes up when the tube is brought within a few feet of the paint, and becomes near-continuous when it is held a few inches away.

The equipment is rugged and can be knocked around, but is a trifle heavy to carry on a hot day, though light compared to the original mine detector. It also carries better at the side, with a strap through the convenient V-shaped channel pieces on the cover and slung over the opposite shoulder, than with the GI harness. Probably the ideal solution would be a small r.f. unit operated with a single Minimax and two flashlight cells. If it would work!



This shows batteries, connectors, bottom view of chassis and side view of the search head.

**CAMERA REGISTERS HEAT**



Dr. Franz Urbach of Eastman Kodak adjusts camera and apparatus for taking pictures by heat.

PHOTOS A through F of a dual rectifier tube were taken by means of the heat of the plates and filament. The apparatus in the large picture is part of a new technique known as thermoradiography developed by Dr. Franz Urbach of Eastman Kodak Laboratories.

The thin white sheet in front of the camera is coated with a phosphor which glows when struck by ultraviolet light. When heat is focused on the phosphor screen by the circular mirror, the efficiency of the phosphor in converting ultraviolet to visible light is decreased in proportion to the heat. Variations in heat show on the screen as shadows.

The camera made the small photos with a duo-diode furnishing the heat. In photo A, the diode was not turned on. In photo B, an image was reflected to the screen by visible light.

Photo C was taken when the filaments had just been turned on. Their hot ends, not shielded by the plates, are visible. With one plate carrying rated current, photo D was taken. In photo E both plates are energized.

After the tube had been in action some time, the glass envelope absorbed enough heat to give off radiations of its own. Photo F shows the thermoradiograph of the envelope.

The process will be used for measuring heat and for determining the distribution of heat over various types of surfaces.

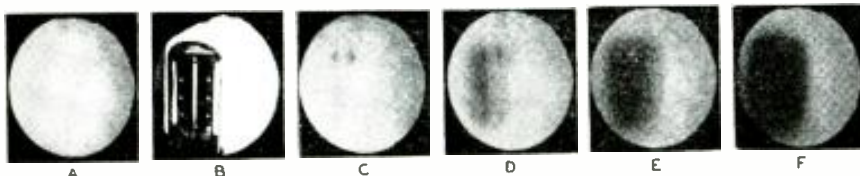

These photos of a conventional duo-diode vacuum tube were taken thermoradiographically.



# Twelve New Vacuum Tubes Introduced

**A** NUMBER of new tubes, some of them especially slanted to television applications, have arrived on the market. Besides the television types, greatest interest is in miniatures and low-power, high-frequency, communications tubes.

A complete line of tubes for replacement in television receivers has been announced by Sylvania. Made to more critical specifications than standard tubes, they are designed to reduce the number of television service calls now required for tube replacements.

The marking "Television Tube" on the base (see photo 1) marks the new series, which will include the 1B3-GT, 6AG5, 6AL5, 6BG6-G, 6J6, 6K6-GT, 7B4, 7B5, 7C5, 7F7, 7H7, 7N7, and 7Z4. Prices will be slightly higher than for the corresponding tubes manufactured for broadcast use.

Three new television tubes, announced by Hytron, are the 6BQ6-GT (photo 2), 25BQ6-GT and 1X2 (photo 3). The BQ6 types are designed for horizontal deflection amplifiers in television receivers, and are constructed to withstand the high peak interelectrode voltages found in these circuits. The plate is brought out through the top of the tube. The 6BQ6-GT has a 6.3-volt, 1.2-ampere filament, while the 25BQ6-GT uses 0.3 ampere at 25 volts and is designed for sets with series-operated filaments. Other characteristics are identical. Tubes operate with 250 plate, 150 screen, and -22.5 grid volts. Plate current is 45 ma and transconductance 5,500  $\mu$ mhos.

The 1X2 is a miniature, filament-type rectifier designed to supply high voltage to the cathode-ray tube in sets using either r.f. or flyback power supplies. Filament current is 200 ma at 1.25 volts, making it possible to operate the filament with r.f. current in power supplies designed for the purpose. Maximum d.c. load current is 1 ma, and peak inverse voltage 15,000. The drop across the tube—measured at the near-peak current of 7 ma—is 100 volts.

The 19BG6-G (photo 4), announced by the General Electric Co., is a beam-power amplifier tube designed for operation at high surge plate voltages for short periods. Its characteristics make it especially useful in horizontal deflection circuits of larger television receivers, and it may be used with picture tubes operating at voltages up to 10,000. The 19BG6-G operates with 500 volts on the plate and d.c. plate current of 100 ma. Peak heater-cathode voltage is 250, with heater either positive or negative with respect to cathode.

In the subminiatures, Raytheon announces the 1AD4 (photo 5), a filament-type pentode with performance approaching that of many heater-



Photos 1, 2, 3, and 4—Sylvania television tube, Hytron 6BQ6-GT and 1X2, and G-E 19BG6-G.

cathode types. This new tube has an average plate current of 3 ma at 45 volts plate and screen supply. It is a sharp-cutoff pentode, shielded for r.f. applications, and has a transconductance of 2,000  $\mu$ mhos. The filament draws 100 ma at 1.25 volts.

Four new subminiatures, comprising a complete portable battery-receiver complement, have been issued by Sylvania (photo 6). They include the 1AD5 sharp-cutoff r.f. pentode, the 1E8 pentagrid converter, the 1T6 diode-pentode, and the 1AC5 output pentode. All filaments are rated at 1.25 volts and 40 ma. Plate voltages can range from 30 to 67.5.

In the communications field we have the 5763 (photo 7), an RCA tube, and the GL5670 (photo 8), put out by General Electric, both low-power tubes designed to operate at a plate voltage of 300. The GL5670 is especially designed for dependability in applications where operation is intermittent and conditions are rugged, such as mobile communications. The heater will stand a great number of off-on cycles. It is similar to the 2C51.

The 5763 is a v.h.f. beam-power tube with a maximum plate dissipation of 12 watts and is designed to operate up to 175 mc with full input. Transconductance is 7,000  $\mu$ mhos. It can deliver about 7 watts in class-C service at 50 mc. It is also recommended as a frequency multiplier. It is recommended for low-power mobile and aircraft transmitters. When used in high-altitude aircraft, the No. 2 pin (no internal connection) should be removed from the socket to prevent arcs between plate and grid. Pins 1 and 3 respectively.

A particularly interesting type is the RCA 5794 u.h.f. oscillator triode (photo 9). The unique appearance of this tube is due to the fact that its tuned circuits are integral with the

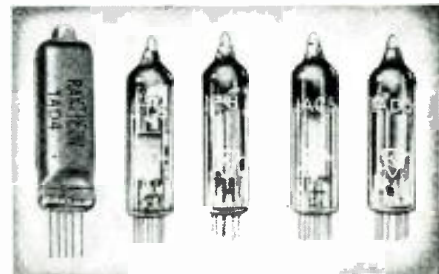
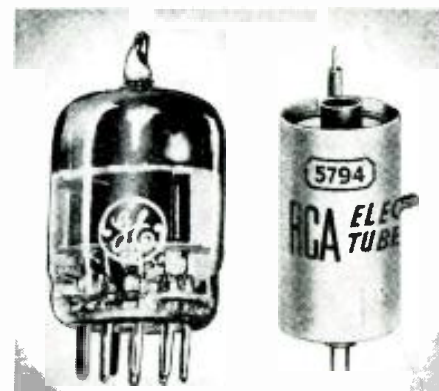

Photo 5—1AD4. Photo 6—1AD5, 1E8, 1T6, 1AC5.

tube itself. It has grid-cathode and grid-plate resonators within it. The screw on the side is for adjusting the frequency to 1,680 mc, and the top projection is the coaxial output terminal, inductively coupled to the plate resonator. This little oscillator is designed for radio-sonde and similar service.



Photo 7—The 5763.



Photos 8, 9—The GL-5670 and the 5794.

# Electronics in Medicine



Photos courtesy Valpey Crystal Corp.

This generator contains an ultrasonic oscillator and amplifier. The transducer is a crystal.

**U**LTRASONICS, formerly sometimes called supersonics, is that branch of acoustics concerned with audio frequencies higher than the upper range of human hearing, that is, frequencies of 20,000 cycles and above. There is no generally accepted upper limit of the ultrasonic spectrum. The nature of the equipment employed is the sole determinant of the output frequency.

Ultrasonic waves are usually produced in one of two ways—with magnetostrictors or quartz crystals. (There are many other possible, but less common, methods.) Fig. 1 is a diagram of a magnetostrictor. The principle on which it operates is that any magnetic rod or tube undergoes minute variations in length under the influence of a magnetic field parallel to its long axis. This phenomenon of magnetostriction (also known as the Joule effect) is a reversible one, therefore, such a metallic rod subjected to an alternating magnetic field, will vibrate longitudinally (lengthen and shorten) and emit sound waves from its ends. Maximum power transfer occurs when the frequency of the alternating current is the same as the natural frequency of the rod, as might be expected.

In the instrument shown in Fig. 1 the magnetic field is produced by the triode oscillator. The magnetic rod is placed in the tank circuit. The variable capacitor  $C$  permits tuning the oscillator frequency until it is the same as the natural frequency of the rod. Best results are obtained when the rod is initially magnetized, because the change in length is greater for a given change in flux density than is the case with unmagnetized rods. This is the reason for the polarization (biasing) voltage fed to  $L$ .

Various types of metals, such as nickel, monel metal, and invar, have been employed for the rod. Use of solid rods results in a low conversion factor of electrical to sound energy, because of

the hysteresis and eddy-current losses. These can be reduced by using a thin-walled, longitudinally split tube.

The major limitation of the magnetostriction oscillator is that its upper frequency limit is restricted by the low natural frequency of the rod. To obtain higher frequencies, shorter rods must be used. To generate ultrasonic waves having a frequency of 50,000 cycles, a nickel rod must be about 5 cm (2 inches) long. Lengths shorter than this are both difficult to mount and difficult to excite. Somewhat higher frequencies may be attained by employing rods of different shapes. It is also possible to obtain higher frequencies by using harmonics of the rod's fundamental frequency. However, this is accompanied by a loss of power output.

For these reasons, quartz-crystal oscillators are used widely where higher-frequency ultrasonic waves are desired. Frequencies up to about 50 mc may be obtained with these instruments. This limit is due to the fact that there is a minimum thinness to which quartz crystals can be cut. The lower limit of quartz crystal oscillators is in the order of 50 kc because of the difficulty in securing and exciting thick crystal blocks. The natural frequency of any crystal depends upon the thickness and the particular electrical axis used. Fig. 2 is the circuit diagram of a typical, commercially designed, quartz-crystal, ultrasonic generator. The basic principle of operation is exactly the same as that of the crystal cutting heads used in making disc recordings. The alternating oscillator output is applied to the quartz crystal, causing the latter to oscillate mechanically in step with the current alterations. The crystal is coupled to a metallic diaphragm from which the ultrasonic waves are emitted.

As can be seen in Fig. 2, the generator is essentially a 6AG7, crystal-controlled, electron-coupled oscillator which is capacitance-coupled to a pair of parallel-connected 807's in the power out-

## Part XI—Ultrasonic waves destroy bacteria and help cancer sufferers

By EUGÈNE J. THOMPSON

put stage. The electron-coupled oscillator, in which the screen-grid is used as the plate together with the cathode and the control grid to form a triode oscillator, is useful because it reduces the loading and coupling effects of the next stage. To shield the plate of the tube from the cathode and the control grid, the screen is operated at r.f. ground potential, putting the cathode and control grid above ground. The output from the plate is regulated by the changes of potential of the control grid and cathode. The effects of loading changes are not great because of the small effect which the plate voltage has on the plate current of screen-grid tubes, and because the plate is not itself in the oscillating circuit.

The oscillator requires no tuning when used with crystals from 100 to 800 kc. The crystal used for controlling the oscillator frequency is matched to the ultrasonic crystal within 0.1%. The load crystal can be coupled directly to the plate circuit with a step-up inductance or by a link and co-axial cable.

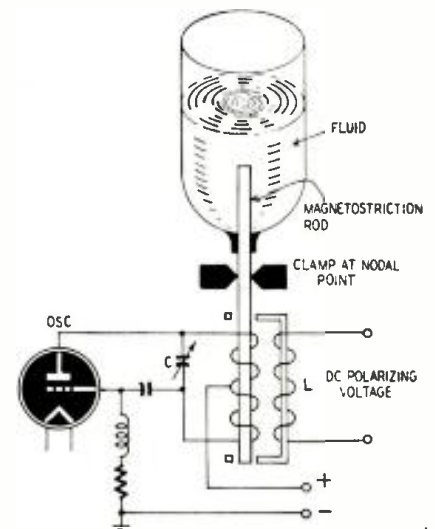

Fig. 1—A simple magnetostriction oscillator.

RADIO-ELECTRONICS for





Waves are propagated by crystal in oil bath.

De-coupling is employed to prevent radiation through the power leads. The plate circuit of the power output stage is tuneable and can be made to cover a wide frequency range with plug-in coils.

The power output is between 50 and 100 watts. This unit is essentially a low-power generator. Of course, higher-wattage instruments are possible—and available—depending on the requirements of the user. The instrument in Fig. 2 is designed for small all-around laboratory work by a reasonably intelligent technician. Because of its low power output, the danger of injury, which is encountered in higher-powered units, is not a problem.

Although the many interesting phenomena observed with ultrasonic waves are due to their short wavelengths—which range roughly between 6 cm and  $2 \times 10^{-3}$  cm—the effects which they exert are not directly related to frequency. However, the biologic effects cannot be duplicated with audible sound frequencies, that is, longer wavelengths. In general, the waves are propagated in a liquid medium, commonly oil (see photo of oil immersion jar) above.

Ultrasonics has many applications, the best known of which is probably *Sonar*, the system of underwater direction-finding employed in World War II to locate enemy ships. In Sonar equipment the ultrasonic waves are modified to make them directional. With two exceptions, this is not the case in medical techniques.

The main medical applications of ultrasonics are four:

1. To paralyze or destroy bacteria. This property is used in sterilizing vaccines and other biological products which are to be injected into the body. (Exactly how the waves destroy bacteria is not known. A foremost theory

is that the troughs and crests of the very short waves set up areas which vary greatly in their pressures, very close to one another. This is thought literally to tear the bacteria apart. Another theory is that bacteria get trapped in cavities formed in the liquid by the enormous pressure differential between the troughs and crests of the waves. The gases in the liquid migrate to these low-pressure areas, forming submicroscopic bubbles in the bacteria which cause them to burst.)

2. To break up crystals of such preparations as the sulfa drugs, thereby increasing the surface area, and making them more effective.

Ultrasonic waves focused with quartz crystals generate enormous amounts of heat at the focal point of the sound beams. This has given rise to two additional applications:

3. Diathermy. As pointed out in a previous article, the object of diathermy equipment is to get the heat into the deeper tissues of the body where the treatment is desired. This can be done by setting the focal point of the ultrasonic equipment so that it is within the tissues.

4. Cancer treatment. This is an application which is now under intensive

investigation. The proponents of ultrasonics believe that it is superior to radium or x-ray treatments because the latter cannot be focused to any great extent and hence destroy healthy as well as cancerous tissue.

At any rate, the unique properties of ultrasonic waves are a certain guarantee that they will probably not only be used more extensively in medical applications of increasing scope, but will also be retained for their present applications, as well as find many uses in the industrial field.



Crystal transducers may be used up to 50 mc

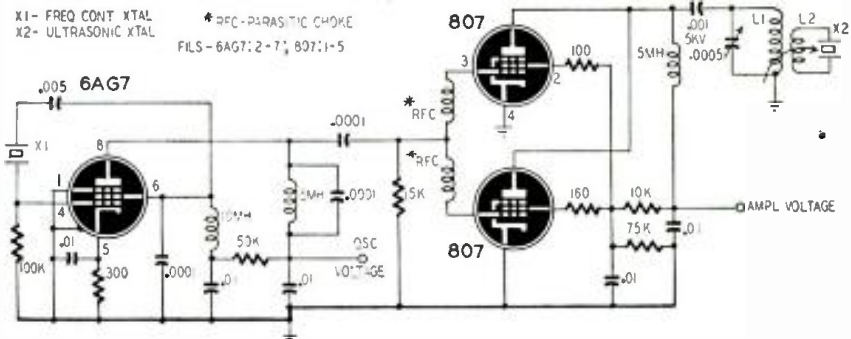

Fig. 2—A larger ultrasonic generator using a quartz crystal to produce the vibrations.

## New Telephone Recorder

THE Tele-Magnet, manufactured by Mohawk Business Machine Corp., New York, is the newest electronic telephone message recorder. It is automatically operated by an incoming telephone call in the absence of the subscriber. The ringing signal causes a magnet to raise the telephone handset. A phonograph record answers the call, giving the name and address of the company. It also informs the calling party that he has 30 seconds to record his message. (Thirty seconds has been found sufficient for most phone messages, but this time can be increased if desired.)

When the owner returns, he can tell at a glance how many messages have been recorded, switch on the wire recorder, and listen to them at his convenience. The voice is reproduced by a loudspeaker built into the metal cabinet.

The wire recorder has a capacity of

seventy-two 30-second phone messages. The device employs 10 tubes. A jack is provided for plugging in a separate microphone for general recording purposes. The phonograph record may be changed as often as the owner may desire.

The Tele-Magnet can be manually operated as a straight wire recorder and may be used for recording both sides of a telephone conversation.



# Intercarrier Televisers Use Common I.F. Channels

By **JESSE DILSON\***

**T**HE best answer to the question, "What's new in television?" is "intercarrier modulation." A number of manufacturers have already produced receivers using the system and it may soon dominate the market.

Actually, the basic idea of intercarrier modulation is simple. The new system is contrasted in the block diagrams of Fig. 1 with the orthodox television setup. The conventional receiver of Fig. 1-a has only one stage in which the sound carrier and video carrier co-exist—the r.f. section. After conversion to the intermediate frequencies, the two

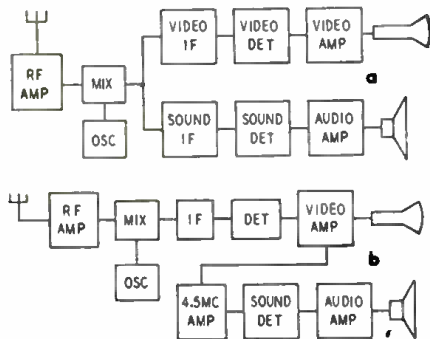

Fig. 1—Intercarrier and standard contrasted.

i.f. carriers—the sound frequency-modulated, and the video amplitude-modulated—are separated and amplified in different i.f. amplifier strips, and each is demodulated by its own detector, the video signal passing on to the video amplifier and then to the picture tube while the audio signal passes on to the audio amplifier.

In the intercarrier system (see Fig. 1-b) the two carriers go along together as far as the video amplifier, and it is not until this stage that the two are separated. To begin with, the sound and picture carriers are broadcast from the transmitter with the center frequency of the sound carrier higher than the video carrier frequency

\*Instructor, Hudson Technical Institute, Union City, N. J.

**Because of economy and ease of adjustment, intercarrier is used in many sets**

by 4.5 mc. Both are picked up by the receiver antenna, and both are amplified in the r.f. section. The unmodulated signal of the local oscillator beats with both carriers to produce a frequency-modulated sound i.f. of 21.25 mc and an amplitude-modulated picture i.f. of 25.75 mc, with the difference in frequency of 4.5 mc still maintained. Both these i.f. signals pass through a common i.f. amplifier.

The diode detector following the i.f. amplifier demodulates the picture i.f. signal in the usual way, producing a video signal. It acts like the first detector in a superheterodyne to give in its output a beat frequency of 4.5 mc. This 4.5-mc signal is frequency-modulated, varying around its center frequency in exactly the same way as the original sound carrier. It is this signal which in the intercarrier system enters the sound detector.

The 4.5-mc signal is prevented from carrying the full amplitude changes of the picture i.f. by attenuating the 21.25-mc sound i.f. signal to a level which makes it small in comparison with the amplitude of the picture i.f. It has been found that best reception is obtained with the i.f. passband as shown in Fig. 2, with the response in the neighborhood of the sound i.f. center frequency at not more than 10% of the level at the picture i.f. carrier. Furthermore, as Fig. 2-b shows, this curve should be reasonably flat 100 kc either side of the 21.25mc point. If this condition were not met, the diode detector would work as a slope detector, partially demodulating the sound frequency variations into a signal which would be amplified in the video amplifier and passed

on to the picture tube as interference. An absorption trap, tuned to a point slightly above the 21.25-mc region, acts to depress the curve to produce the "shelf" shown in the curve of Fig. 2-b.

Why the amplitude modulations of the 4.5-mc signal will be negligibly small if the sound i.f. level is properly

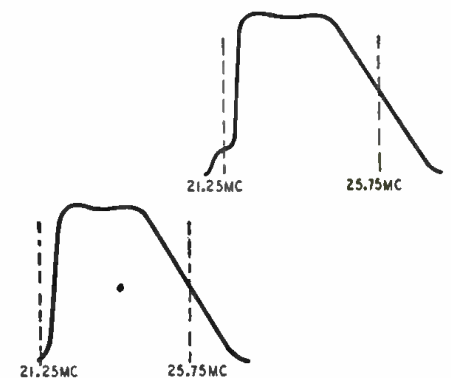

Fig. 2—I.f. responses of two receiver types.

attenuated, can be explained with the help of Fig. 3. If two unmodulated waves *A* and *B* of unequal frequencies are mixed, at some moment the two will be in phase and reinforce each other, and at another moment they will be out of step and oppose each other. If the amplitude of *B* is small compared with that of *A*, a wave *C* will result—that is, an amplitude-modulated carrier whose envelope is a wave with the small amplitude of *B* and with a frequency equal to the difference in frequency between *A* and *B*. Now, if wave *A* should change in amplitude, the amplitude variations in *C* will re-



main much the same as before, provided *A* is always large compared to *B*.

If *B* is frequency-modulated, the envelope of *C* will vary in frequency exactly to the extent that *B* varies, since the frequency of *C* is equal, at any moment, to the difference between the frequencies of *A* and *B* at that same moment. In this example *A* represents the picture i.f. signal, *B* the sound i.f. signal, and the envelope of *C* the 4.5-mc signal. After detection, then, the 4.5-mc signal will have small variations in amplitude, but will change in frequency as fully as the sound i.f. signal changes.

To step up this weak signal to the point where it can properly drive the sound detector, it must be amplified. This is done by the 4.5-mc amplifier shown in the block diagram of Fig. 1. The amplifier has a limiter action which keeps the 4.5-mc level constant despite changes in amplification of the i.f. stages caused by the operator's manipulation of the contrast control. Since the 4.5-mc signal is carried through the video amplifier, it will appear on the grid of the picture tube, causing an interference pattern, unless it is eliminated. A trap between the video amplifier and the picture tube does the job effectively.

The schematic diagram of Fig. 4 shows in some detail the setup of circuits following the last i.f. amplifier in a typical intercarrier receiver. The resonant circuit on *C1* and *L1* is the

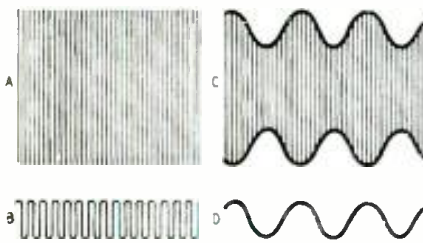

Fig. 3—How AM is removed from sound signal.

absorption trap already mentioned which is tuned to the 21.25-mc sound i.f. and which is designed to shape the low shelf in the response curve of Fig. 2. The output of the video amplifier is the point of separation of sound and video. The series circuit of *C2* and *L2* is across the entire plate load of the video amplifier tube; and with *L* adjusted so that the two resonate at 4.5 mc, the 4.5-mc voltage output of the video amplifier fed to the picture-tube cathode is too weak to appear in the screened image. Although the 4.5-mc voltage across both *C2* and *L2* is low, the drop across *L2* alone is relatively large for that frequency. This voltage is strengthened in the 4.5-mc amplifier, and is demodulated by the ratio detector.

Alignment of the intercarrier receiver differs in only a few details from that of the orthodox television set. I.f. stages are stagger-tuned in much the same way as in the conventional receiver. Sound traps in both receivers are tuned to the same frequency and can be aligned in like manner. The 4.5-

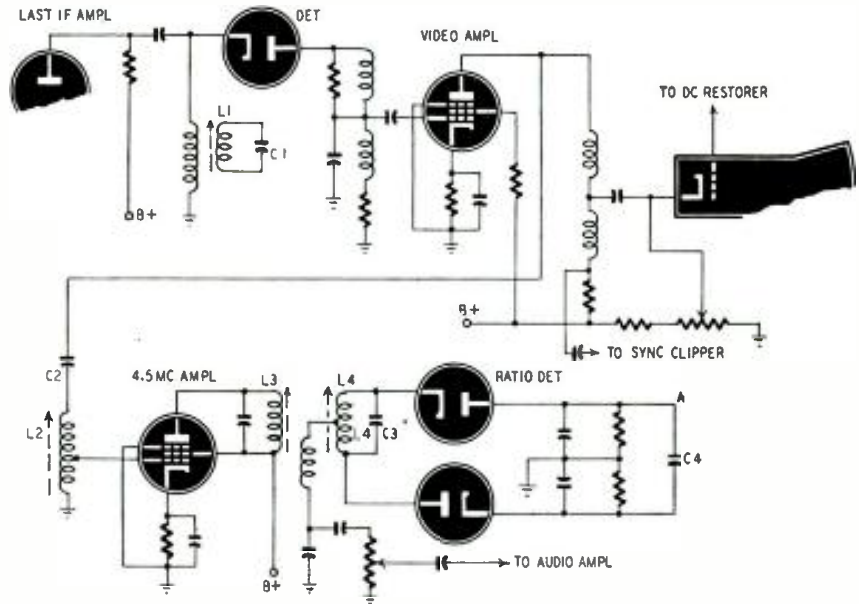

Fig. 4—A schematic of the sound and video detectors of one typical intercarrier receiver.

mc trap and the tuned circuits of the ratio detector can be simultaneously set by feeding an unmodulated 4.5-mc signal to the grid of the video amplifier, hooking a vacuum-tube voltmeter from point *A* in Fig. 4 to ground with one end of *C4* temporarily disconnected, and tuning *L2*, *L3*, and *L4* for maximum reading on the meter.

A glance at the block diagrams of Fig. 1 shows one very obvious advantage—economy. With no sound i.f. strip necessary, the manufacturer—and, of course, the public—is saved the price of three tubes together with their circuit components. This also saves the service technician trouble. There is no sound i.f. to align.

Oscillator drift, which in the conventional television set means poor sound, is no problem in the intercarrier system. With the 4.5-mc difference between sound and picture carriers fixed at the transmitter, the sound signal entering the ratio detector is always at that frequency, regardless of oscillator variations. If the oscillator should shift, both sound and picture i.f.'s will change by the same amount, and the 4.5-mc difference between the two will remain unchanged. Elaborate circuits to keep the oscillator stable are unnecessary.

This fact is also responsible for the absence of a fine tuning control on intercarrier receivers. This control, which in conventional receivers consists of a small variable capacitor in the oscillator tuned circuit, is needed to correct for the shifting in the sound i.f. carrier encountered in switching from one channel to another. In the intercarrier receiver, such a control is generally superfluous.

On the other side of the ledger are these drawbacks: For one thing, 100% modulation of the picture carrier causes it to disappear momentarily. Of course, with the absence of one of the two heterodyning carriers, the 4.5-mc sound signal vanishes, and with it the sound. Suppose, in a televised scene, one very

bright point—say, a spangle on a performer's dress—appears. The video signal corresponding to that point would be almost zero, as shown by *A* in Fig. 5, which shows the r.f. video carrier. And at that point, the amplitude of the carrier is practically zero. Such a bright point is likely to persist in the televised scene for at least several seconds. If the sound disappears and reappears once per frame, that is, once every 1/60 second, 60-cycle hum may be heard in the speaker.

Then there is the problem of phase modulation at the television transmitter. Unless special precautions are taken, the phase of the video carrier is likely to be modulated along with its amplitude. The 4.5-mc signal is sure to be similarly affected and to be demodulated into sound interferences.

The solution to these difficulties is in the hands of the broadcaster. The first, of course, can be prevented by proper monitoring, so that the carrier

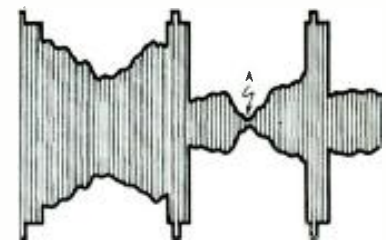

Fig. 5—Zero video modulation blanks sound.

amplitude may not be allowed to fall below 10% of its maximum (peak of the sync pulse) value. Prevention of the second is a matter of adding the proper equipment to the transmitter. It has been found that the components of the video signal within the audible range are much reduced in strength, and that therefore phase shifts of up to 15 to 20 degrees can be tolerated by the intercarrier receiver. That neither of these problems is serious is shown by the ever-increasing number of intercarrier receivers on the market.

# TELEVISION TRANSCRIPTIONS



Fig. 1—Photographing the monitor. Edge of a monitor tube may be seen in the rear rack.

FOR greatest economy in network telecasting, each station in a network must be supplied with the program originating at the main studio. At present, co-axial and microwave links do not provide adequate service for the major television networks. The networks have solved this problem by recording studio programs on film. This film, together with its accompanying sound, is sent by air express to each network affiliate who does not get service from the co-ax and microwave relay routes.

Even where an electronic link is available to a network affiliate, it is often desirable to use film teletranscriptions either because the cost of co-ax service is very much higher than that of film, or because of the flexibility of programming possible with film.

Film makes it possible for a station to rebroadcast transcriptions of many programs otherwise unavailable to it, as in cases where the desired program takes place either on some other network or at some impractical time on its own network.

At Du Mont we have been working on the problem of recording television programs on film for a good many years. I shall outline the path followed and the general results which have been achieved, as well as how the system is now being used.

The first attempts at recording television programs on film were made with a standard silent, 16-mm spring-wound camera operating at 16 frames per second. With the low light intensity of early television monitors, it was necessary to use the fastest film emulsion available at that time (approximately 100 Weston). The nonsynchronous action of the camera, combined with the synchronous 30-frame-per-second television image, resulted in a film transcription which contained banding or

## Teletranscriptions add variety to programs of stations outside relay network

By RICARDO MUNIZ\*

horizontal lines of over- and under-exposure caused by the uneven matching of the odd and even television fields recorded on each frame of the film.

Next we tried running the camera at 15 frames per second with a synchronous motor. This eliminated the banding, and recorded every "other" frame of the television transmission, thus reducing the resolution or definition to one-half of the transmitted image. It was still impossible to record the accompanying sound track on the film, since it normally requires 24 frames per second speed.

At this stage it became obvious that for commercial utilization, recordings of the 30-frame-per-second television picture would have to be made at 24 frames per second, so that the 16-mm film could be projected either in a conventional sound projector for direct viewing or a standard projector for television rebroadcasting.

In the next model, the original camera shutter was replaced by a 72-degree closed shutter, and the pull-down was accelerated to approximately 42 degrees so that it would occur when the shutter was closed. The camera mechanism was

It was then decided to turn the building of a commercial camera over to the Eastman Kodak Company. The resulting cameras are shown in Fig. 1, which also illustrate the setup for recording the television picture on film. It will be noted that the camera is focused upon the screen of a cathode-ray tube located in a rack-and-panel mounted picture monitor. It is on the screen of this tube that the television image appears and from which it is photographed.

### Recording equipment

For continuous recording of television programs on film, it is desirable to employ a double system of operation which uses two recording channels. Each of these is composed of one specially designed television monitor, which reproduces the television picture, one picture recording camera, and one sound-on-film recording camera. The sound and picture cameras should be capable of operating 1,200-foot magazines. These provide 35 minutes of recording time and make the system more convenient for continuous recording. A desirable accessory is a high-quality receiver for recording off-the-air programs.

The television picture monitor, from which the image is photographed, must be provided with the composite television signal taken from the main program bus of the broadcasting station. Picture quality is maximum at this point. The signal from the telecaster's program bus as well as the air signal are generally led into a patch panel on the monitor console which is also provided with a sync stretcher (see RADIO-ELECTRONICS, March, 1949, page 24) and a stabilizing amplifier. The recording operator thus is able to switch instantly to any combination of line or air signals desired. A similar arrangement is used for the sound recording cameras.

### Monitor problems

To record top-quality pictures on film, the monitor picture must be perfectly steady in every phase of its operation. The monitor is therefore designed to eliminate—as far as possible—any and all possible fluctuations in



Fig. 2—Example of poor linearity. The circle may be distorted horizontally or vertically.

not otherwise altered, nor was the operating speed. This model eliminated the recording of 6 frames per second of the 30-frame television picture during the camera pull-down time and recorded the television image at the standard sound film speed of 24 frames.

This model was a decided advance, but left much to be desired in the motion and steadiness of the resulting images.

\*Division Manager, Television Receiver Mfg. Division, Allen B. DuMont Laboratories, Inc.



either picture size, brilliance, linearity, or position. To assure this, the high voltage is supplied from a heavily regulated power supply. The cathode-ray tube has a special screen material of a very fine grain, and is operated at a voltage high enough to reduce to a minimum the spot size of the electronic beam. This provides the maximum possible resolution of the picture provided by the program bus.

### Linearity

Obviously the linearity of the picture recorded on the film must be as nearly perfect as possible. The film will be used by the various affiliates of the network throughout the country, and any nonlinearity in the picture will be reproduced. It is also important that the linearity adjustment of both monitors be *identical* to eliminate any differences in picture linearity as the film from one camera is flashed to the film from the other camera every half hour or so to make a continuous recording. Effects of poor linearity can be spotted very quickly on a test-pattern transmission. This is illustrated in the test pattern of Fig. 2, where the perfect circle of the normal test pattern is seen as the distorted oval shape produced by poor linearity in the horizontal or vertical directions.

A very important factor in producing commercial-quality results in teletranscriptions is the use of a *gamma control* (which controls the gray scale in the electronic picture) to match the characteristics of the film being used. Failure to exercise the utmost care in making this adjustment will result in pictures with a contrast range which may produce either washed-out pictures on the home receiver or images consisting essentially of chalk and soot. The recording operator's maximum skill is called upon here. A picture with too much contrast is compared in Fig. 3 with a television image of normal contrast.

For high quality a positive picture is used on the monitor; however, a negative picture which reduces processing time—where that is an essential factor—can be produced. In using a negative picture on the monitor, a reverse blanking signal must be generated to hide the return trace lines which otherwise would be visible in the recorded picture. To reduce optical distortion to a minimum, a 12-inch cathode-ray tube is used, but the picture is held to 6 by 8 inches and located near the central and relatively flat portion of the tube face. This tube is customarily operated at 25,000 volts, for maximum resolving power.

The highlight intensity available from the cathode-ray tubes in our present television monitors is approximately 150 foot-lamberts. This makes it possible to employ a slow, positive type of film stock with a Weston rating of about 1, if the motion picture camera has a lens aperture of f2.

### Operating the equipment

The picture and sound cameras in

the channel being used are started simultaneously by a relay system. Synchronous motors drive both units, thereby locking together the separate picture and sound recordings. Ten seconds after starting, both films are fogged by "bloop" lights, thereby providing time-registration for making the final composite print.

If both the recording equipment and the station are located on the same power line, the camera and the television transmitter will run synchronously. If they are not, there will be a tendency for the lap-dissolve regions on the recorded image to creep up and down at the rate of the difference frequency between the 60-cycle supply driving the transmitter and that driving the camera. A critical adjustment of shutter angles will eliminate banding movements.

### Choice of technique

The reader may wonder why direct

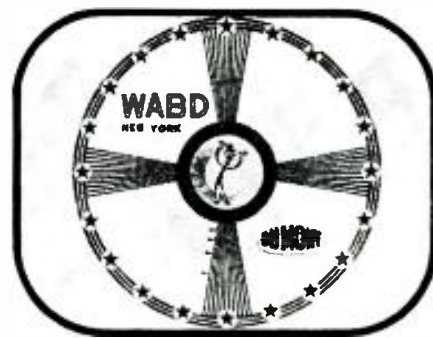
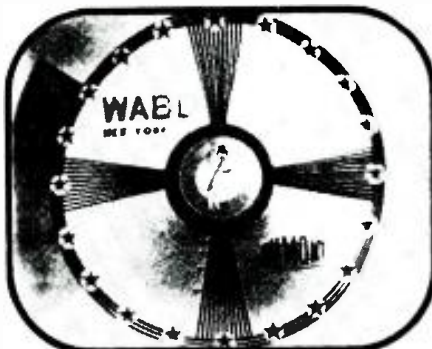

Fig. 3—Too much contrast causes effect at left. Compare with normal contrast at right. film recordings of the actual studio programs are not made instead of photographing the image on the cathode-ray tube monitor. Obviously, many of the critical factors encountered in recording from the monitor would thus be eliminated.

You have but to visit a telecasting station in operation to appreciate the reason for this choice of technique. In the program control room, you see lined up before the console operator three or four different images from the cameras in operation in his studio. The cameramen endeavor to keep a picture of air quality on each camera according to the prearranged schedule at rehearsal.

The program director decides which of these pictures shall go on the air at a given moment, in effect, editing the program material as he goes along, so that the program as it goes on the air will show different camera angles, different viewpoints, and the like, and will, in general, be a finished, well-rounded product in comparison to any individual recording which could be made with a single camera operating continuously in the studio.

### Theater television

A modification of the system, using 35-mm equipment, has been applied to theater television. A negative picture is produced on the cathode-ray tube, resulting in a positive photographic

image on the 35-mm film, on which both the picture and sound are recorded simultaneously. From the camera the film is fed directly into a rapid processing machine, where it is developed, fixed, washed, dried, and then fed directly into the projection booth of the theater, all in a minute or less from the time of exposure. It is then projected on the theater's screen in the conventional manner.

### Use of teletranscription

Teletranscriptions are now being used by transcription affiliates of the Du Mont Network in Detroit, Cleveland, Los Angeles, Albuquerque, Houston, San Francisco, Seattle, St. Louis, Baltimore, Salt Lake City, Atlanta, Buffalo, New Orleans, Philadelphia, Syracuse, Erie, Dayton, Cincinnati, Memphis, Boston, Milwaukee, Washington, and Miami. These recordings include both studio programs and sports teletranscribed at Station WABD in New

York City, and flown to the transcription affiliates according to prearranged schedules.

### Utilization

The teletranscriptions have also proven invaluable in gradually improving the skill of cameramen, program directors, and engineers. Each teletranscription is shown at least once to the cameramen who participated in the program, their program directors, and the operating engineers of the station. At this time, errors in dramatic or technical presentation can be noted. As their origin is identified, an opportunity is provided for constant improvement in programs and telecasting quality. Such improvement would otherwise have been impossible, since it is not practical for any one member of the team to view the on-the-air results of their combined efforts, except by teletranscription.

Incidentally, the teletranscription represents a legal record of what went on the air and might thus conceivably be useful as a legal document.

The author wishes to acknowledge the most active cooperation of Harry C. Milholland, Manager of the Teletranscription Department of the Allen B. Du Mont Laboratories, Inc.; of Commander Mortimer Loewi, Division Manager of the Telecasting Network Division of this company; and Dr. T. T. Goldsmith, Jr., who directed the research on the teletranscription project.

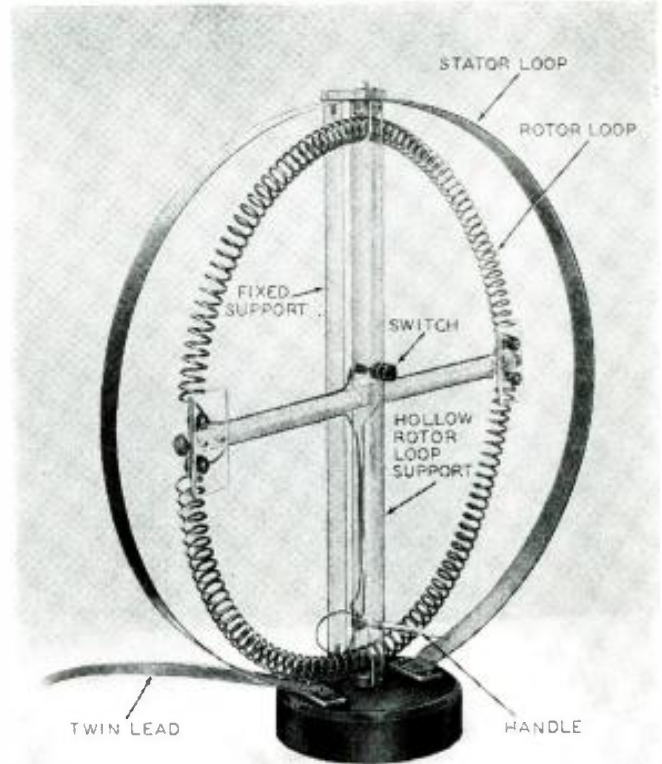
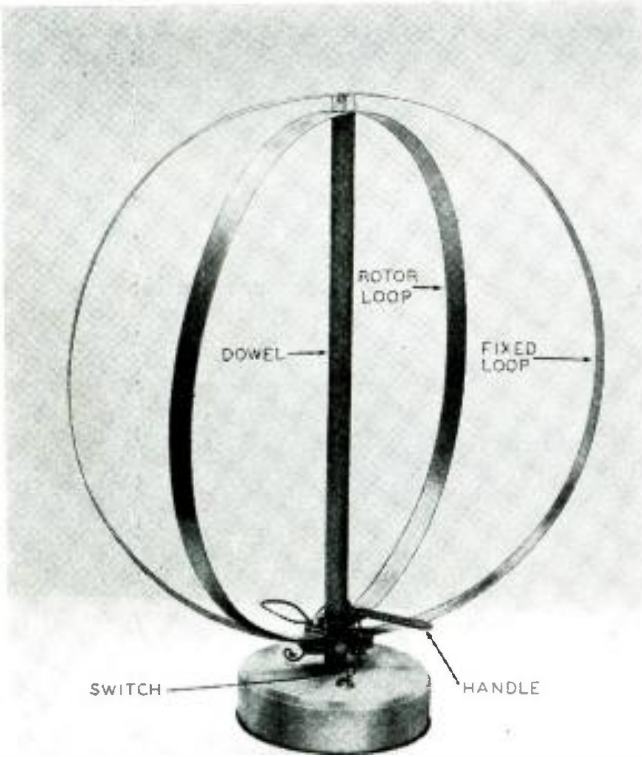

Simplified version of the Variotenna described in last month's article.

The Inductive Transpole Variotenna introduces some new principles.

# THE TRANSPOLE VARIOTENNA

## Part II—Later models of the new television antenna are shown here

By HUGO GERNSBACK

In the last issue I described in detail two indoor television antennas which I recently designed. The article concluded with the Transpole Variotenna which used 3/8-inch-thick aluminum loops. As it is difficult to bend such heavy stock, unless one has access to a machine shop, I developed a simple model anyone can make at a cost that should not exceed \$2.

The photograph shows in detail the appearance of this model. Its only drawback is that it admittedly does not make as good an appearance as the one illustrated on page 28 of the August issue.

Fig. 1 shows construction details of a simple version of the improved Transpole Variotenna. For the two metal loops, one fixed and one movable, 9 feet of stiff brass strip about 3/4 by .032 inch (No. 20 A.W.G.) is required. The upright support is a 17 1/2-inch length of wooden dowel having a 3/4-inch diameter. The wooden base is 6 inches in diameter and 1 3/4 inches high.

The outer (stationary) loop is supported on the top of the dowel by a short length of Lucite or polystyrene rod, 3/4 inch in diameter and 1/2 inch long, drilled and tapped for two 4-36 machine screws which pass through two holes drilled in the outer metal strip. A hole is drilled in the center of the Lucite to admit a small nail which serves as a bearing for the inner rotatable loop, a suitable hole being drilled in the center of the inner loop at the top for the purpose.

The two lower ends of the inner movable loop are mounted on a 1 1/4 x 2 1/4-inch piece of 3/32-inch Micarta (or Lucite), drilled for two 4-36 machine screws on each side, as illustrated. A large hole is drilled in the center of the Micarta strip to allow free rotation about the dowel.

The free lower ends of the outer fixed loop are held in place by two strips of Micarta, 3/32 inch thick, and 1 1/4 x 2 1/4 inches in size. Two holes are drilled through either side of the two Micarta

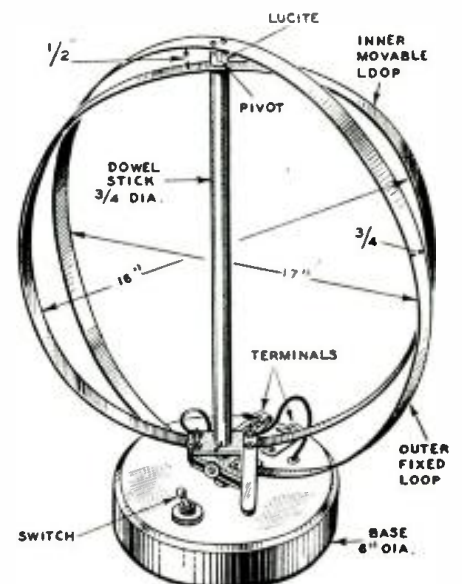

Fig. 1—Construction details of variotenna. RADIO-ELECTRONICS for



strips, so that long 4-36 machine screws can be passed through them to clamp the metal strip ends, and also to furnish terminals (extra units and washers) to which connection may be made. A wood screw and washer is fastened to the wood dowel stick, the screw being

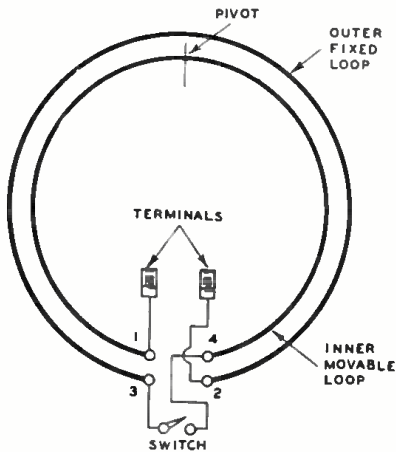

Fig. 2—The connections are as shown above.

passed between the two Micarta strips so that they cannot turn.

It being undesirable to bring one's hand too close to the inner movable loop to rotate it, fit a Micarta or Lucite handle to the support of the movable loop, as the photo shows. This handle is fastened on the two 4-36 screws clamping the metal loop to the Micarta support strip.

The spacing between the two metal loops should be 1/2 inch, the space between the fixed and rotor loops at the base being regulated by a couple of heads driven into the dowel stick.

The diagram of connections for the antenna is shown in Fig. 2. The leads from the TV set are connected to opposite ends of the inner and outer loops, as shown. This is the Transpole hookup. The remaining free ends of the two loops are connected to a shorting switch, as shown in the diagram. The lead wire used to make the connections to the loops and the switch, and also to the two terminal posts, should be flexible insulated stranded wire.

Keep leads short! It is best to drill two holes in the base to accommodate two Lucite tubes and to pass the antenna leads through these. The two spring binding posts are best mounted on a piece of Lucite or Micarta.

On the Variotenna the four lower ends of the ribbons are the hot points. Placing your hands or arm inside the loops may throw out the television image entirely.

In tuning, it will be found that there is usually one best position for a given station. The switch also is important because on some stations reception will be much improved in one position or the other.

**Inductive transpole variotenna**

A somewhat different Variotenna also has given excellent results, perhaps even a little better than the two Variotennas described before.

The principle remains the same, except that the inner, variable loop is no longer a single conductor, but is formed of two separate spiral brass coils, each mounted in a semicircle as the photo shows. The two sections, therefore, form almost a complete circle. The diameter of the coils is approximately 3 1/4 inch, and the turns are spaced 1/4 inch. Each coil contains 11 1/2 feet of No. 10 A.W.G. hard brass wire. This is a very heavy wire, and a machine shop (or a lathe) is needed to wind the coils. Use a 1/4-inch spacer to keep the turns apart when winding.

The inner loop, made up of the two coils, is supported at top and bottom by passing the coils through a vertical Lucite tube measuring 1 inch in diameter and 18 1/2 inches long. This tube turns to rotate the inner loop.

There is also a horizontal supporting rod (5/8-inch Lucite, 17 1/2 inches long) which supports the ends of the two coils. A switch in the center of the Lucite tube shorts or opens the Transpole connection, as shown in the connecting diagram (Fig. 3).

Like the other models the rotatable double loop swings around its center. It can be carefully adjusted by a small Lucite handle attached to the large Lucite tube. A 5/8-inch-diameter Lucite rod, 18 1/2 inches long, supports the top Lucite cross bar (2 3/4 inches long x 3/4 inch wide x 1/4 inch thick) to which

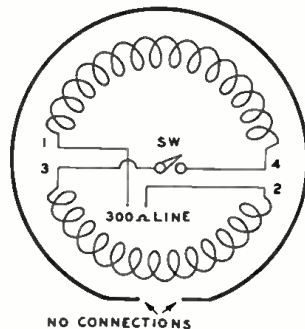

Fig. 3—Wiring for the Inductive Transpole.

the stationary loop is fastened. A pin or bearing is fitted in the crossbar and also the base, on which the central Lucite tube turns.

The connecting wires from the two sections of the loops are cemented to the central horizontal rod, and then are conducted through the main Lucite tube to the base of the antenna, where they are connected to the flat lead-in.

Encircling the rotor loop is a flat strip of No. 20 A.W.G. brass 1 inch wide and 18 1/2 inches in diameter. This strip is attached to Lucite insulators mounted on the wooden base.

It should be noted that no electrical connections are made to the outer loop. The two sections of the rotor loop end in screw connections mounted on Lucite pieces, which in turn are secured with machine screws to the horizontal rod.

This antenna worked very well when tried in a number of poor locations in New York. In many cases it was not only possible to bring in stations normally difficult to get on an indoor an-

tenna, but "snow" and "ghosts" could be eliminated readily.

A model of this Variotenna was tested by Messrs. Matthew Mandl and Edward Noll of Temple University. In Mr. Mandl's report he said:

I have just completed checks on your new indoor loop antenna [the one illustrated in Fig. 3] and find it has characteristics which differ materially from your original one [that of Fig. 1 and its counterpart in the August issue]. The first thing I noticed was that maximum pickup for the antenna is from the ends of the loops—and not broadside. [See Fig. 4.] This type of pickup is the same as that procured from the ordinary loop antenna in a table radio—with the edge of the flat loop pointed toward the station. It is also similar to the way direction-finding antennas work.

With your first antenna [Fig. 1] it was difficult to assign a pattern configuration to it because the two loops were positioned in various ways for different stations. With the present one, however, the pattern characteristics are pretty definite.

I also found that on the low-frequency channels the antenna worked best when the inner [rotor] loop was displaced slightly in plane from the outer. That is to say, I had to turn the inner loop about 5 degrees with respect to the outer for maximum pickup. Orientation was rather critical, and in the same general plane anywhere within the room. This would indicate that the antenna is less susceptible to room reflections than others would be.

On the higher channels I found that best reception was when both inner and outer loops were in the same plane.

With respect to gain, I would say that it is very good and about equal to your former antenna—though it seems that there is a slight gain increase with this antenna on the lower channels.

The only problem with this antenna is that it is difficult to construct in its present design. Perhaps other experimenters will be able to simplify it.

It should be noted that in this particular model it is absolutely necessary that the four connections be in the horizontal plane. If the antenna is turned around so that the connections are top and bottom, it will work poorly.

I should be very happy to hear from those who have tried the various models of the Transpole Variotenna.

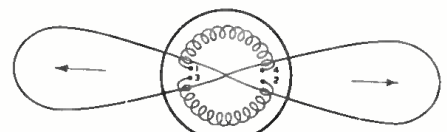

Fig. 4—Inductive Transpole field pattern.

# Citizens Band Opened To Public for Regular Use

**A survey of the new rules governing 460-470-mc operation and equipment**

**By JULIAN P. FRERET**

**D**O you want to chat with your neighbor down the street, or operate a model airplane by remote control, or open your garage doors without getting out of the car? The Federal Communications Commission has just "taken the wraps off" the citizens band, providing for these and other uses on a regular basis. In the past, transmitters designed for the 460-470-megacycle band were authorized only under rules governing experimental radio stations, and were accorded "experimental" status. Now new revised regulations have been issued for stations in the citizens radio service and a simplified application form adopted.

Under the new rules, which went into effect June 1, applicants may request permission to construct and operate a station in the citizens radio service, without making the showings required for a general program of radio experimentation. In simplest terms, this may mean the difference between getting a license quickly and expeditiously and the comparatively complex requirements heretofore in effect; it might even mean the difference between getting a license and not getting one.

The new regulations will remain valid until modified or amended by the Communications Commission. No significant modifications for the 460-470-megacycle band are now contemplated. The new application form (a single card instead of the multipaged form in use when all stations in the band were classified as "experimental" under the old rules) became effective simultaneously with the revised rules. These new rules have been designated Part 19 of the FCC's regular series of regulations.

Although several features of the old procedures have been retained in Part 19, many changes have been made. The most significant departure from the old method of license application is in the streamlined handling of requests to use *type-approved* equipment (transmitters which have been tested and approved by the FCC). It is still necessary to

receive a "construction permit" as well as a station license, but for type-approved equipment the single application card is sufficient for the issuance of a license. Operators using type-approved equipment receive class-A licenses. If the applicant has constructed his own transmitter or modified one originally designed for other purposes, it is classified as *composite*. Operators of this type of equipment receive class-B licenses.

For the issuance of a class-B license permitting operation of composite equipment, a person must file a copy of FCC Forms 505 and 403 and a "technical showing" (including measurements and data purporting to show that his composite equipment is capable of strict compliance with the technical requirements—especially as concerns frequency deviation—of the citizens Radio Rules). If the technical showing is approved by the Commission and the station license issued, no additional commercial or other operator's license is required for a citizens radio station not using manually operated radiotelegraphy. That is, no other license is required for the actual *operation*, i.e., communication and use of the station.

Adjustment of any citizens band transmitter, which affects the output characteristics, such as frequency, percentage of modulation, etc., must be made by or under the supervision of the holder of a first- or second-class commercial radiotelephone or radiotelegraph operator's license. The purpose of this is fairly obvious: an unskilled person may use his set for the purpose intended, provided he does not manipulate its controls in such manner as to put it out of the frequency band, overmodulate it, or even injure himself by electrical shock. This provision of the citizens rules is designed to insure in a measure that the equipment will be operated according to the rules. Note also that only a licensed commercial operator can service citizens band transmitters or transceivers.

Users of transmitters which have been tested and type-approved by the

FCC need not worry about adjustment or misadjustment of their apparatus. One of the conditions under which a certificate of type approval is issued is that the set be sufficiently tamper-proof to prevent its being operated in violation of the engineering rules for the service. So far, only one set has been approved—that manufactured by the Citizens Radio Company of Cleveland—but more are expected as the citizens band comes into general use. In time to come, the average radio fan will no doubt be able to buy an approved transceiver in any department or sporting goods store.

## **A mobile service**

Unless a specific request is made that a station be designated as "fixed," all transmitters will be considered mobile and may be operated at various locations. The reason for this becomes apparent when one considers the FCC's requirements for radio operator's licenses: A mobile station in the citizens radio service may generally be used without an operator's license, provided voice modulation is employed; a fixed station requires an operator's ticket of the second class or better.

Up to the adoption of the new regulations, interest in the citizens band was slow, and only about 150 licenses had been granted. Inquiries of all types, however, vastly outnumbered applications. No doubt the new simplified rules and the increased availability of equipment will skyrocket the number of persons getting on the air on 460-470 megacycles.

First publicized approximately two years ago, the citizens radio service was accorded recognition of a sort in late 1947 when the FCC established technical and engineering standards for stations to be ultimately licensed on a regular basis. From the time of its conception until June 1 of this year, the citizens band was on an experimental basis, and all operations were strictly in accord with the rules governing experimental stations. The FCC now ap-



parently feels that the period of experimentation is over and regular operation may be permitted.

### Equipment for 460-470 mc

As manufacturers make new equipment available, it is expected that a great deal of home-built composite apparatus will be relegated to the spare parts corner, and that the newly engineered transmitters and receivers will make for better, more effective use of the band. Except for experimental development of new mobile equipment, virtually all work in the 460-470-megacycle region has been done with modified war-surplus gear. In particular, the BC-645, an airborne transponder for IFF use, has been pressed into service on the citizens band and used with varying degrees of success in many localities. These sets are still available in the surplus market at prices ranging from \$7.50 to \$20.00, but require modification before they may be used for voice communication on the 460-470-megacycle frequencies. From time to time, modification details have been published in various periodicals, and many surplus houses furnish data sheets with the purchase of equipment. Anyone may purchase and rebuild or modify a BC-645 without a license of any sort, provided he does not put it on the air where it may interfere with other communications. Further, anyone without a license may turn it on and adjust it *within the confines of a shielded room or space*. However, when this modified set is to be turned on and adjusted so that actual radiation in space will occur, then a licensed commercial operator must effect the adjustments.

The BC-645 may be modified to comply with the engineering standards of the citizens radio service; but these changes may be extensive, and a complete redesign of the set might prove more practicable. A BC-645 that has been modified and licensed (class-B license) and that has been properly adjusted by or in the presence of a licensed operator may then be operated by an unskilled person who has a citizens band license.

Not a long-distance band, the citizens frequencies have been allocated with a view to providing reliable communications over several miles and a minimum of interference between stations in the citizens and other radio services. Under favorable conditions, transmissions may be received over longer ranges. In reasonably open country, line-of-sight characteristics of the frequencies used play a dominant part, and trees and buildings may attenuate the signals seriously. Experiments and tests seem to indicate, on the other hand, that in urban areas reflections from buildings and other objects fill in the shaded areas and provide communication comparable to that furnished by ordinary v.h.f. transmission. As the higher frequencies find more widespread application, more practical data will become available on the capabilities of the band, and reliable ranges may be revealed greatly in

excess of those expected.

Licenses for citizens radio stations will be issued for a period of 5 years from the date granted, and the registration number appearing on the license form will serve as the "call" of the station. In addition to being a citizen of the United States, anyone planning to operate in the citizens band must be 18 years of age or older. Code tests or other examinations are of course not required, except in special circumstances, such as for the use of radiotelegraphy or code signals instead of voice modulation.

### Plethora of applications

And what can John Citizen use his station for? With two or three noteworthy exceptions, for almost anything! He cannot use it to carry entertainment material of any kind either directly or indirectly; the FCC thinks one regular broadcast band is enough. He cannot use it for direct transmission through public address systems, for, since the citizens' band is on a come-one-come-all, catch-as-catch-can basis, with no protection against interference from other citizens stations, a crowd may be disappointed when Aunt Minnie down the block comes in full blast just before the winning touchdown! Neither can a station be used for warning or control purposes requiring continuous operation of the carrier; interference would be too great if many stations were on the air continuously. Further, citizens radio stations are not permitted to carry communications for hire.

It is not possible to determine beforehand exactly what does or does not constitute a communication for hire, and the FCC will probably have to determine each case from the facts.

The list of uses to which citizens stations may be put grows daily. In addition to applications in fire and burglar alarms, applicants may well consider

garage door openers and other automatic control devices about the home, automatic warning devices for hunters, remote controls for model airplanes, boats and cars, baby tenders and of course all manner of communications from home to office to car.

As the number of functioning stations grows, the different types of operation will grow apace. A temporary restriction, however, has been placed on the band by the FCC. Until a comprehensive study can be made, and a plan adopted, those would-be users who may be eligible for licensing in some other radio service will not be granted citizens authorizations, thus excluding police, industrial, fire, aircraft, and other services with assigned bands.

Although technical standards remain unchanged from when the Experimental Rules of the FCC were applicable, they will be of interest to anyone considering getting on the air on 460-470 megacycles. Two classes of stations are permitted, A and B. The former must maintain a frequency tolerance of .02% of the frequency on which the transmitter is adjusted to operate, and may be used anywhere in the band. The power input to the plate circuit of the final amplifier tubes may not exceed 50 watts, except on frequencies of 462-468 megacycles, where it is 10 watts. Class-B stations are assigned a frequency of 465 megacycles, and all operation must be confined to within + or - .4% of that frequency. Maximum input for class-B stations is 10 watts. Maximum modulation percentage for amplitude-modulated stations is 100%, and self-excited oscillators are limited informally to 30% in accord with Commission engineering practice. It is expected that under the new rules and as the citizens band becomes increasingly popular, operators will be required to observe all technical requirements strictly.



David Crandall, author's co-experimenter, modifies a surplus BC-645 for the citizens band.

# MICROWAVES

## Part V—Special sections of waveguide are employed as transformers

By C. W. PALMER

IN addition to the impedance transformers used in microwave installations mentioned in a previous installment of the Microwave series (which usually take the form of cavity resonators) there are also transformers which permit changes from one type of waveguide to another; one mode to another; from waveguide to co-axial line.

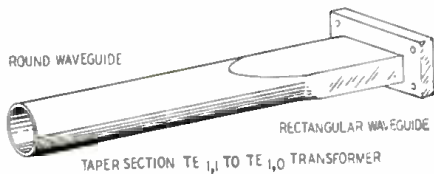

Fig. 1—Taper section changes shape of guide.

One example is in changing from the lowest mode of one size guide to the lowest mode of another as between the  $TE_{1,0}$  mode in rectangular waveguide to the  $TE_{1,1}$  mode in circular guide. It is usually advantageous to use the lowest mode of a waveguide which explains why so much of our discussion is based on the  $TE_{1,0}$  mode in rectangular guide. (An exception to this rule is in the use of rotary joints to permit rotating an antenna through 360 degrees or through a desired wide angle.)

In changing from rectangular to circular guide a tapered section is generally used because a taper can include a gradual transformation of shape as well as size, as demonstrated in Fig. 1.

A tapered section is used to transform from a rectangular guide of one size to one of another. The length of the taper determines the reflection introduced. In general the longer the taper the better, though short tapers can be used if the length is carefully chosen. Fig. 2 shows how standing-wave ratio decreases in an oscillating fashion as taper length is increased. It can be seen—as an example—that a ratio of taper length to wavelength of 0.98 is as good as one of 3.63, whereas a ratio of 1.2 introduces a standing-wave ratio of 1.09 compared to 1.03 for the long taper or the carefully chosen short one.

A long taper is less frequency-sensitive than a short one and therefore is usually preferable.

The second type of transformation is from the lowest mode of one size of guide to a higher mode in another, for

example, from rectangular guide  $TE_{1,0}$  mode to round guide  $TM_{0,1}$ .

The main consideration here is that if a junction is formed between two kinds of waveguide, one of which will operate in more than one mode, then it must be considered that all the propagating modes will be set up at the junction.

To correct this it is desirable to construct the junction so that the desired mode is excited at a higher level than the unwanted ones. Further preference for the desired mode can then be introduced by the use of filters such as resonant rings, dipoles, etc., to limit activity of the undesired modes, and by the use of an inductive window near the junction to match the guide to the desired mode.

Fig. 3 shows several examples of the above matching, using matching stubs, dipoles, and resonant rings to produce the desired results. At a are shown the stub and ring with the stub length equal to one-half wavelength and the position of the ring one-quarter wave-

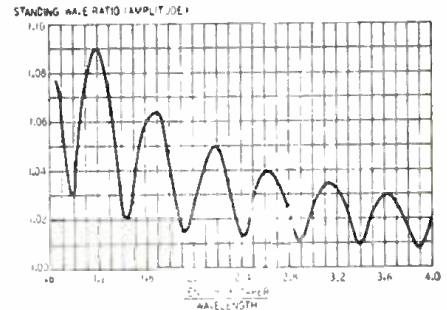

Fig. 2—Length of taper determines the s.w.r.

length for the  $TE_{1,1}$  mode. This results in suppressing the  $TE_{1,1}$  mode and supports the  $TM_{0,1}$  mode in the round guide. A matching diaphragm completes the transformer. At b the relation of diameter  $D_1$  and  $D_2$  with the stub and diaphragm suppresses the undesired, and supports the desired, mode.

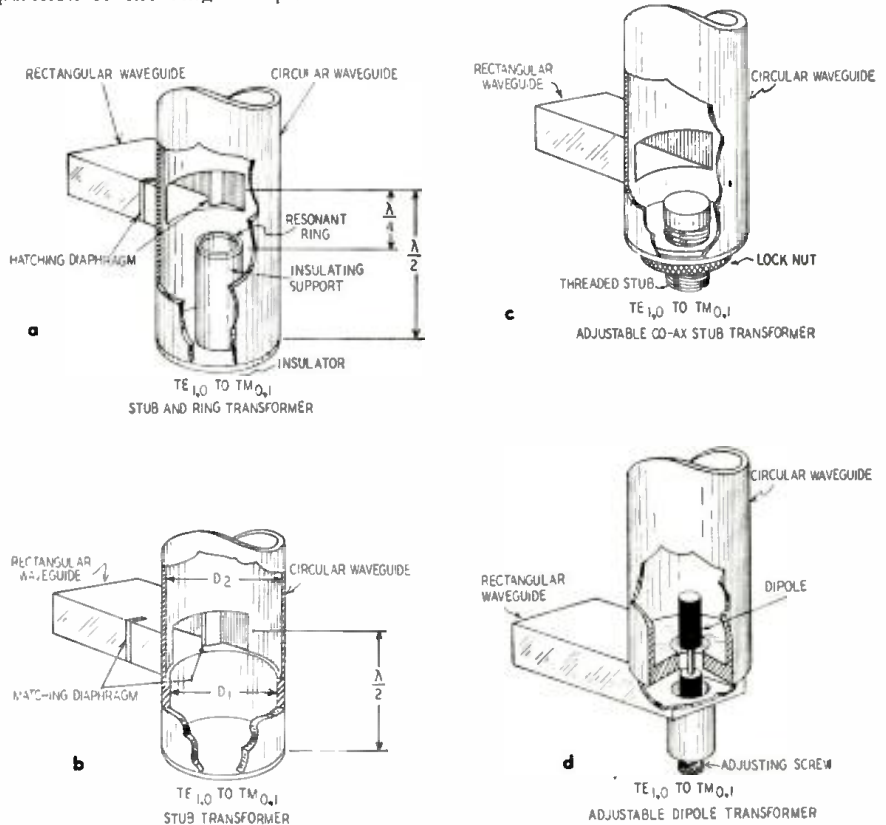

Fig. 3.—These are waveguide transformers used to match circular guides to rectangular ones.



At c an adjustable stub is used while at d an adjustable dipole suppresses undesired modes.

**Wave guide to co-ax**

The third type of transformer is from waveguide to co-axial line or the reverse. Even though we have shown that the waveguide is preferable for frequencies above a certain point in the microwave region (see Part 1) there are occasions when it is necessary or desirable to feed a signal into or from co-axial line and connect this to a waveguide circuit. One case of this is in coupling magnetron tubes with co-axial feed to waveguide circuits.

Fig. 4 shows several ways of transforming from waveguide to co-axial line. At a is shown a probe feed in which the center conductor of the co-axial line projects into the broad face of the rectangular waveguide approximately a quarter wavelength. The end plate of the waveguide being approximately a quarter wavelength from the probe, all power is radiated and adds in phase with that radiated directly down the guide.

At b is a modification of the system at a, but a "doorknob" is substituted for the probe for higher power.

At c and d are two forms of stub coupling. A tuned probe projects through the waveguide into a stub that provides a large coupling loop linking all the flux between the co-axial center conductor and the waveguide end plate. The type shown at d provides an adjustment of the gap between the outer conductors to permit maximum coupling.

**Rotary joints**

A specialized form of waveguide transformer is the rotary joint used to permit antennas to rotate through wide angles, yet prevent discontinuities that would rob power from the circuit. See the photograph on this page.

The rotary joint provides a rotatable linkage that is symmetrical regardless of the angle of rotation and thus does not introduce strong reflections at one angular position and weak ones at another angle.

To obtain this axial symmetry, the  $TM_{0,1}$  mode in circular guide is usually used since this is the lowest mode with the desired characteristic. In its most common form, rectangular waveguide fed at  $TE_{0,1}$  mode is transformed in the rotary joint to  $TM_{0,1}$  in circular guide and thus connected to the antenna rotary elements. Another commonly used rotary joint utilizes a short section of co-axial line connecting two rectangular waveguides. The center conductor of this co-axial line projects into the guide of the rotary antenna at one end and into the waveguide from the transmitter at the other.

Succeeding parts of this microwaves series will: continue the discussion of the waveguide apparatus; take up circuits and systems for transmitting and receiving using the apparatus we have

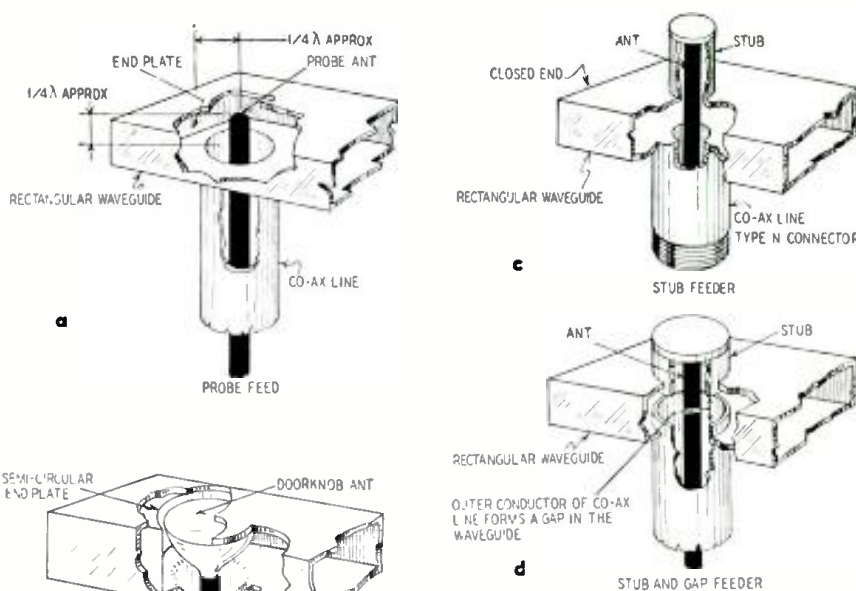

Fig. 4—Four waveguide-to-co-axial sections.

not travel directly down the inside of the guide. They are reflected from one side of the guide to the other in zig-zag fashion. Thus the length of their path is the angular length instead of the axial length. As the operating frequency is increased above the waveguide cutoff frequency, group velocity approaches (but does not reach) the velocity in free space.

Phase velocity is the product of frequency times wavelength. The wave-

discussed; review the types of antennas used for microwave frequencies; take up a study of microwave test equipment and methods of making measurements, and the problems of measuring power at these intriguing microwave frequencies.

On p. 47 of last month's installment (numbered par. 6) we stated that "the wavelength in a waveguide . . . is always greater than in air." This statement is correct, and the following explanation may clarify it:

There are two velocities of energy propagation in a waveguide, namely, group velocity and phase velocity. Group velocity is less while phase velocity is greater than in free space. Group velocity refers to the propagation down a guide and must be less than in free space because the waves do



Courtesy De Mornay Budd  
Commercial rotary unit for rectangular guide.

length in a waveguide is actually the distance between two planes of the same phase perpendicular to the direction of propagation. In a waveguide this is longer than in free space because of angular reflections. The apparent velocity is therefore greater for phase velocity than in free space.

**CIVIL SERVICE POSITIONS FOR SCIENTISTS**

Applications are now being accepted by the Board of U. S. Civil Service Examiners for the Potomac River Naval Command in Washington, D. C., for positions as electronic scientist in various Federal agencies in Washington, D. C., and in the states of Maryland, North Carolina, Virginia, and West Virginia. Most of the positions to be filled are in the Bureau of Standards of the Department of Commerce and in activities within the Potomac River Naval Command.

Salaries for electronic scientists range from \$3,727 to \$10,305. No written test is required. To qualify, applicants must have completed a four year college course with major study in a

field of physical science, mathematics, or engineering, or have had four years of scientific or technical experience in one of these fields. In addition, applicants must have had from one to four years (depending on the grade for which application is made) of professional scientific or engineering experience which included at least one year of electronic research and developmental work. Provision is made for the substitution of appropriate graduate study for two years of the required experience.

For complete details on the requirements to be met for these positions, consult Announcement No. 4-34-4 (49) at any first- or second-class post office.

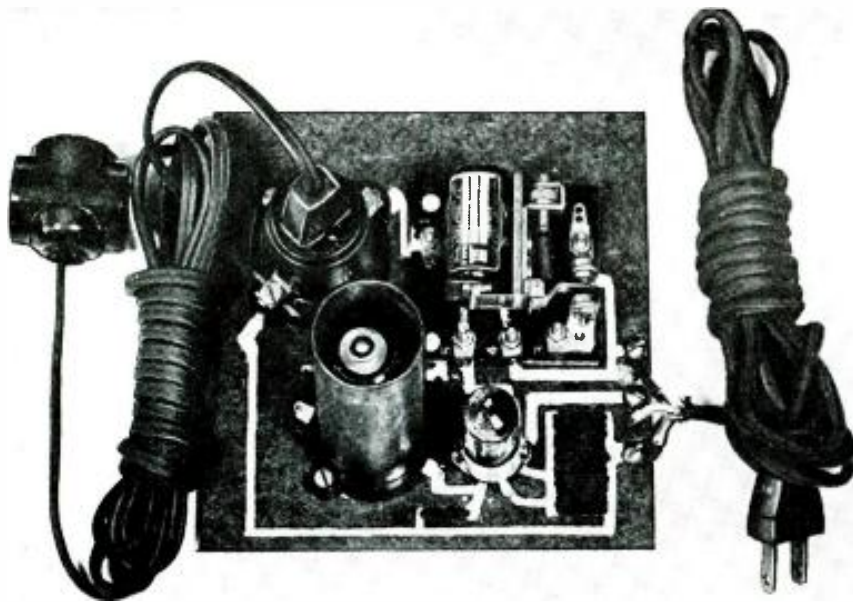

Assembled photoelectric relay has no wired connections except for line cords and capacitor.

New kit of paints allows experimenters and development engineers to make their own printed circuits, obviating need for special equipment

By ROBERT F. BRADLEY\*

## Paint Your Own Printed Circuits

**P**RINTED-circuit experimenting has spread from the manufacturers' research department to the work bench of the individual experimenter.

The exciting possibilities of pocket-size radios, hearing-aid receivers that can be placed in the user's ear, and even a functioning wrist radio have been described vaguely in technical publications. They leave the reader with an intense interest, but with no realization that he, himself, can build any of them. References to the actual methods of manufacture of commercial printed circuits discourage the average radio experimenter; they require high-temperature baking equipment, accurate stencil screens with their associated equipment, and conducting and resistance pastes, many of which are specially prepared for the particular circuit being printed.

Now, the college engineering department, the individual experimenter, the service technician, and the engineer whose company cannot economically maintain the experimental equipment and develop the generally unobtainable paints, may adapt printed circuits to their own interests and needs with the help of kits containing all the paints needed for experiment, repair, and design. The paints may be applied with an artist's brush or ruling pen, eliminating the expensive equipment required for application by mass-production methods. The paints cure by air-drying

in a few hours or by mild heating in any gas or electric oven.

### A sample circuit

A relatively simple phototube circuit was selected for demonstration of painted circuits by representatives of the Microcircuits Company because, relatively easy to hand-paint in the quantities needed, it shows that conducting paints will handle reasonably large amounts of power and that the resistors may be painted easily in a wide range of resistances and wattages.

Fig. 1 is the circuit diagram. Briefly,

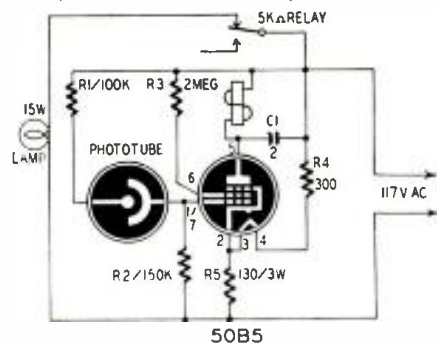

Fig. 1—Schematic of the phototube circuit.

the operation is: The line-cord resistor R4, the 50-volt heater, and the printed self-bias resistor R5, are selected to limit the heater current to 0.15 ampere, the rated value. By Ohm's law, the total heater-circuit resistance is

$$R4 + R_{\text{heater}} + R5 = \frac{E_{\text{Line}}}{I_{\text{Heater}}} = \frac{115}{0.15} = 766 \text{ ohms.}$$

Application of the same law to the

heater gives its resistance as 330 ohms. From a previous knowledge of the phototube's characteristics, it was decided to use a bias voltage of approximately -20 volts. With this value and the heater current of 0.15 ampere, the bias resistor was calculated to be 130 ohms. This leaves 306 ohms. A 300-ohm line cord was therefore used.

The control grid circuit consists of R1, the phototube, and R2, all in series. The phototube not only permits a flow of current approximately proportional to the light striking its active surface, but acts as a rectifier as well. The current passed by the tube controls the signal or grid voltage across R2. Since both the heater and grid circuits are primarily resistive, the voltages across R2 and R5 are in phase. When R2 is carrying only the small dark current of the phototube, the grid will be driven negative by almost the entire 20 volts (effective) developed across R5.

When the tube is rendered conductive by light, the voltage between cathode and grid will be the difference between that across R5 and R2, and will be less than 20 volts negative. This results in increased current flow through the plate circuit and relay coil. R3 was chosen to limit the plate current to the maximum acceptable value of 4 ma.

The relay has a 5,000-ohm coil and operates on approximately 1.6 ma. Since it is very sensitive and the current through its coil is rectified half-wave a.c., the 2-uf electrolytic capacitor C1 was added to smooth or filter the relay-coil current and prevent chatter.

RADIO-ELECTRONICS for

\* President, Microcircuits Co., New Buffalo, Michigan



As painted, the circuit does not have maximum sensitivity. Instead, it was arranged—for demonstration purposes—to provide an oscillating system with the lamp which was controlled by the relay contacts. Since the normally closed set of contacts is used, the lamp is normally on. Its light strikes the phototube, which actuates the circuit and opens the relay contacts. When the contacts open, the light is extinguished and the grid voltage, and therefore the relay coil current, drops. This allows the contacts to close, the light to go on, and

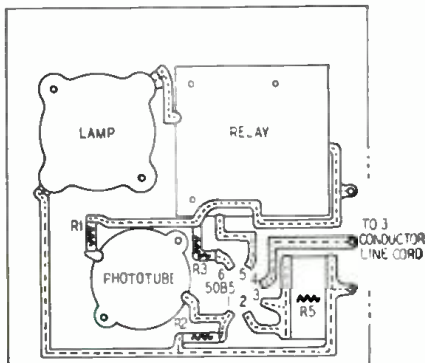

the cycle to repeat. To make a more orthodox circuit, insert a bell, lamp, or other warning device where the present exciting lamp is connected in the circuit, and use an independent lamp for the exciting source, as in the hookup shown in the photo at the head of this article.

**Circuit layout**

A trial step preceding the layout was to assemble all the large circuit elements which could not be printed, arrange them on a sheet of paper, and draw connecting lines between them. Since crossing lines require extra time to construct, an arrangement (Fig. 2) which avoided them was selected.

**Resistor dimensions**

Next the space requirements and dimensions of the painted resistors were determined with the aid of tables from the manual *Design and Repair of*

*Printed Circuits*, a Microcircuits publication sold with the kit of circuit paints. Tables I and III are reproduced here.

In each table the resistance and wattage for a given resistor are found in the square located at the junction of the horizontal column (its width) and the vertical column (its length). The upper number in the square is the resistance; the lower number, wattage.

Resistance is a function of the width, length, thickness, and characteristics of the paint used. Wattage is a function of heat-radiating surface, and is nominally taken as 10 watts per square inch. This is satisfactory except for large resistors, in which slight variations in thickness may concentrate heating in certain areas.

The current through R1 and R2 is 40 microamperes or less; therefore, the wattage to be dissipated will be 0.00016 watt for R1 and 0.00024 watt for R2. R3, with a resistance of 2 megohms and a current of not more than 100 microamperes, must dissipate 0.005 watt. R5, with a resistance of 130 ohms and a current of 0.15 ampere, must dissipate 3 watts. It was decided both for illustration and for a large safety factor to give this resistor a capacity of 4 or 5 watts. This was done by making the resistor 1 3/8 inches wide and 3/8 inch long, the length always being taken in the direction of current flow. Although the table does not show resistors with dimensions greater than 1 inch, the problem may be simplified by assuming two resistors in parallel, one having a width of 1 inch and a resistance of 187 ohms, and the other a width of 3/8 inch and a resistance of 500 ohms. The parallel resistance is 135 ohms, and the combined wattage is 5.2 watts.

The same resistance value may appear in several places, with different wattages, on the same table. We find that the 100,000 ohms required for R1 may be found on Table II (a table similar to Table I, but for medium-resistance paint R21) in a resistor 1 inch long and 1/8 inch wide, with a wattage of 1.2. In Table III—for high-resistance paint R31—resistors 1/8 inch by 3/8 inch and 1/4 inch by 3/8 inch both have nearly the desired resistance. All wattages being larger than necessary, the smallest one, 1/8 inch long by 3/8 inch wide, is satisfactory.

Again using Table III, a resistor 1/8 inch long and 1/4 inch wide has a resistance of 0.156 megohm, close enough to the desired 0.15 megohm for R2. A resistor 3/8 or 1/2 inch long and 1/8 inch wide would be satisfactory for R3, since both values are close to 2 megohms. R4 is a 30-ohm line cord.

With the resistor dimensions determined and the tube socket connections located, it was relatively simple to draw the layout of Fig. 2. It will be seen that R1 and R2 do not coincide with the dimensions determined above. This is because in the experimental model photographed they were painted with medium-resistance paint R21 to give resistance values which were too low. They were then reduced in size with

TABLE III

High-Resistance Paint R31 (One Thickness)  
(40,000 Ohms to 2,500,000 Ohms)

Width (Ins.)	Length In Inches (Resistance Values In Megohms)							
	1/8	1/4	3/8	1/2	5/8	3/4	7/8	1
1/8	313 15	625 3	938 5	1 25 6	1 56 75	1 87 .9	2 18 1 1	2 50 1 2
1/4	156 3	313 6	468 1 0	625 1 2	780 1 4	935 1 6	1 08 2 2	1 25 2 5
3/8	104 5	208 9	313 1 5	414 1 8	522 2 2	625 2 8	730 3 3	835 3 7
1/2	78 6	156 1 2	234 2 0	313 2 5	390 3 0	468 3 7	546 4 4	625 5 0
5/8	63 8	125 1 6	188 2 4	25 3 1	313 3 8	375 4 6	437 5 5	500 6 2
3/4	52 9	104 1 9	156 2 9	208 3 7	260 4 5	313 5 5	364 6 6	416 7 5
7/8	45 1 1	90 2 2	135 3 4	180 4 2	225 5 2	270 6 3	315 7 7	357 8 7
1	39 1 2	78 2 5	117 3 7	156 5 0	195 6 2	235 7 5	275 8 7	313 10 0

sandpaper and a fiberglass eraser until the resistances reached values which gave the desired circuit characteristics. After values had been established by this technique, subsequent circuits were

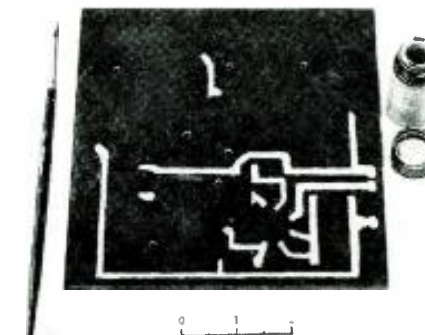

Fig. 3—The board with conducting lines drawn.

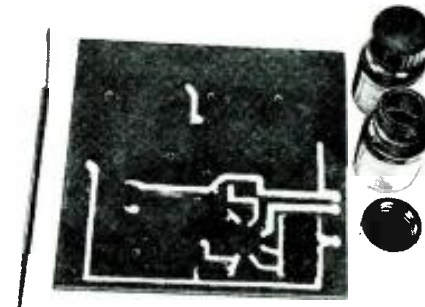

Fig. 4—All the resistors are now "inked in."

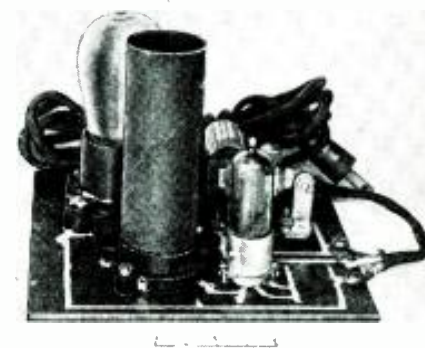

Fig. 5—The completed demonstration circuit.

TABLE I

Low-Resistance Paint R11 (One Thickness)  
(60 to 4,000 Ohms)

Width (Inches)	Length In Inches (Resistance Values In Ohms)							
	1/8	1/4	3/8	1/2	5/8	3/4	7/8	1
1/8	500 15	1000 3	1500 5	2000 6	2500 7.5	3000 9	3500 11	4000 12
1/4	250 3	500 6	750 1 0	1000 1 2	1250 1 5	1500 1 8	1750 2 2	2000 2 5
3/8	167 5	335 9	500 1 5	665 1 8	830 2 2	1000 2 8	1165 3 3	1330 3 7
1/2	125 6	250 1 2	375 2 0	500 2 5	625 3 0	750 3 7	875 4 4	1000 5 0
5/8	100 8	200 1 6	300 2 4	400 3 1	500 3 8	600 4 6	700 5 5	800 6 2
3/4	84 9	168 1 9	252 2 9	333 3 7	417 4 5	500 5 5	584 6 6	665 7 5
7/8	72 1 1	144 2 2	216 3 4	285 4 2	357 5 2	429 6 2	500 7 7	570 8 7
1	63 1 2	125 2 5	187 3 7	250 5 0	315 6 2	375 7 5	438 8 7	500 10 0

# New Tape Recorder Kit



All items in photograph above are furnished with kit except microphone and phonograph disc.

**T**APE recorders have now been added to the radio equipment that may be built from kits. The first available tape-recorder kit, as the photographs indicate, comes in two units. One is a tape mechanism consisting of the necessary tape-pulling equipment, separate erase and record heads, and a 10-inch, 78 r.p.m. turntable for playing records. The other is a five-tube recording and playback amplifier.

The kit—made by Tapetone Manufacturing Corp. of Brooklyn—is a genuine postwar job with instructions handled in the modern style made popular by television kits. Five large 15 x 22-inch sheets contain the wiring instructions for the amplifier. Each shows only part of the total wiring, thus preventing crowding of leads on the wiring diagram. Three smaller sheets (11 x 15

inches) carry the parts list, schematic diagram, and a front-chassis perspective drawing of the completed amplifier. Assembly of the tape mechanism is explained in five 11 x 15-inch sheets, which show the various steps in the mechanical assembly and the connections to be made on leads to the amplifier unit.

Instructions (which run to 28 type-written pages) are simple enough to explain the necessity of tinning the soldering iron to the beginner, and technical enough to give the mechanism's frequency-response characteristics and correct oscillator data for the advanced sound technician who wishes to design and build his own amplifier.

The kit contains all parts necessary for operation, except the microphone and speaker.

## PAINT YOUR OWN PRINTED CIRCUITS

(Continued from previous page)

painted with resistors having the dimensions computed above.

With the layout completed, the next step was to transfer it to a suitable base upon which to apply the paints. This was done by placing the layout over carbon paper on a piece of hard fiberboard. The circuit was transferred to the fiberboard by tracing the lines with a hard pencil.

The silver-paint lines were then drawn with a fine brush, although for narrow lines a ruling pen and straight-edge give neater results. The result is shown in Fig. 3.

After allowing the silver to dry for about 20 minutes, the resistors were painted. They were painted with brush strokes parallel to the direction of current flow. Fig. 4 shows the board after the resistors had been painted.

Following the drying of the resistors,

the 50B5 and phototube sockets, the relay, and the lamp base were added. Their connections were completed with drops of silver paint and painted lines running from the base plate up to the terminals of the relay and sockets.

The result was a circuit which had no connecting wires other than those in the power cord and the leads of the capacitor C1, which were soldered directly across the coil terminals of the relay.

Fig. 5 is the completed circuit, which is also shown in the photo at the head of this article. Note that Fig. 5 is the oscillating circuit, with the 10-watt lamp mounted on the board and shining through an opening in the sleeve around the phototube. In the other photograph, a lead is plugged into the socket so that the circuit can be used for controlling any desired electrical device.

Perhaps the most interesting feature of the equipment is the absolute minimum of switches. Plugs and jacks are used for operations which require correct coincidental setting of two switches on some recorders. Enthusiasts who have recorded long pieces with the amplifier switch on PLAY will appreciate this feature.

The amplifier proper is a high-impedance input type with two 7C7's and a 6V6. It uses inverse feedback. The plate of the 6V6 is coupled back to its own grid through a network containing a .0005- $\mu$ f capacitor and two 510,000-ohm resistors. A .00025- $\mu$ f capacitor is between their junction and ground, as shown below. There is a normally shorted resistor of 100,000 ohms between this capacitor and ground. Cutting this resistor into the circuit feeds back more highs, thus reducing upper-register response.

The bias-erase oscillator is a 6SJ7 in a phase-rotating circuit. Its plate is coupled back to the grid through a two-resistor, three-capacitor network which feeds output signal back into the input in the correct phase to produce sustained oscillations. The oscillations—which are in the order of 30 kc—are amplified through a 6V6 with a 150-

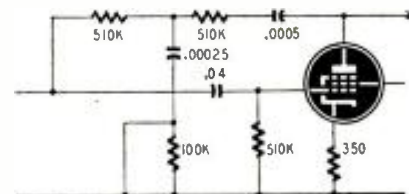

Removing short from resistor decreases highs.

millihenry choke in its plate circuit. They are applied to the erase head through a .01- $\mu$ f capacitor and to the record head through a 100,000-ohm resistor and .00025- $\mu$ f capacitor.

## Design characteristics

Since some constructors will desire to construct or redesign their own amplifiers to use with the Tapetone mechanism, the instruction sheets contain two pages of design data for those who wish to "roll their own."

We learn that the amplifier should have a rising characteristic of 10-12 db from 1,000 to 8,000 cycles for recording, and of 4-8 db both from 1,000 to 8,000 cycles and from 1,000 to 100 cycles for playback.

A correctly designed oscillator should operate at from 25 to 35 kc, supplying maximum current of 2.5 ma to the erase head and approximately 1 ma to the record head. Due to the high impedance of the heads a high oscillator voltage (about 400 at 25-35 kc) is required to drive sufficient current through the heads.



# Fundamentals of Radio Servicing

## Part VII—Resonant circuits

By JOHN T. FRYE

**T**UNED circuits do for the radio engineer what good looks do for a girl: they allow him to select what he wants and reject what he does not want—from the available alternating current spectrum. This ability to put out the welcome mat for a particular frequency and to cold-shoulder others is of utmost importance. It permits the engineer to “tune” his radio circuits, and without tuning there would be no radio as we know it.

Since all tuned circuits consist, essentially, of combinations of a capacitor and an inductance, their variety is not infinite. In fact, they come in just two models: the *series* and the *parallel*, of which Fig. 1 and 2 are illustrations. Note carefully that the two types are determined by whether or not the *applied voltage* is inserted in series with the capacitor and inductance or whether both of these circuit elements are arranged in parallel with this applied e.m.f. A parallel tuned circuit is *not* so named because the capacitor and coil are in parallel with each other, but because both of these are connected in parallel with—or directly across—the *applied voltage*. In a series circuit, the applied current must go through *both* coil and capacitor; in a parallel circuit it has its choice.

Suppose the series circuit of Fig. 1 is connected across a generator of constant voltage but variable frequency. Then suppose we change from a very low to a very high frequency. Recalling that the reactance (resistance to the passage of a.c.) of a capacitor goes down with an increase in frequency whereas the reactance of a coil goes up, we can see that at a low frequency the excessive capacitive reactance prevents much current from flowing through our series circuit. At the high frequency, on the other hand, our capacitive reactance decreases, but the inductive reactance rises sharply and still prevents a great deal of current from passing. However, at some one frequency, called the *resonant frequency*, the reactance of the coil and that of the capacitor will be exactly equal, and the current will rise to a maximum value.

The reason for this rise in current is clear when we remember that capacitive reactance and inductive re-

actance are *opposite* in sign and must be combined like positive and negative numbers in algebra. Remember that a capacitor causes the current to rush *ahead* of the voltage, but an inductor holds it lagging *back* after the voltage; therefore, when the two are in series, the one undoes what the other does. This means that at resonance our total reactance is equal to the sum of two numbers equal in value but opposite in sign—or zero. Since the reactances cancel, the only thing impeding the flow of current through the series circuit is the ohmic resistance.

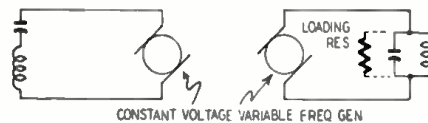

Figs. 1 and 2—The series and parallel tanks.

The lower this resistance is, the higher the current at resonance, as is shown in Fig. 3. When resistance is increased, it flattens out the current peak; but since the resistance enters the picture seriously only in the immediate vicinity of resonance, the curves tend to coincide at points removed from resonance and at which the capacitive or inductive reactance is much greater than the resistance.

At the resonant frequency, the sizes of the coil and the capacitor are such that the time necessary for charging and discharging the capacitor is equal to the time needed for building up the current through the inductor and letting it die down. The discharging ca-

pacitor sends a heavy pulse of current through the coil; and when this current dies down, the collapsing magnetic field returns this charge to the capacitor. Look at Fig. 4. Suppose we had a coil and capacitor hooked up as in Fig. 2 and were able suddenly to put a big negative charge on one of the capacitor plates, as in 4-a. Electrons would immediately attempt to flow around to the other plate to neutralize the charge and get everything back to normal again. But in doing so, they have to flow through the inductor. This sets up a magnetic field which tries to oppose their passage. At 4-b we see a big magnetic field and no excess of electrons on either plate. The current is ready to stop flowing. But now the magnetic field starts to collapse, forcing electrons around (still in the same direction) onto the bottom plate of the capacitor. By the time the field has collapsed entirely, the situation is as in 4-c, and the electrons, now crowded onto the bottom plate, start to flow around to the top

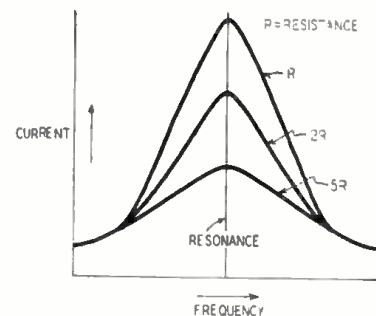
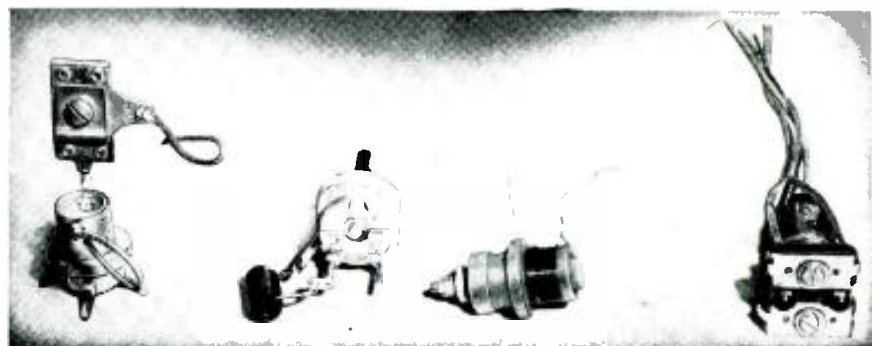

Fig. 3—Resistance effect on series circuit.



Typical tuned circuits: wavetrap, high-frequency receiver tank, slug tuner, transformer.

again, producing the condition of 4-d, which is identical with 4-b, except that current is flowing in the opposite direction.

At resonance, the swapping of energy is precisely timed, and heavy current is moved through the circuit. At frequencies other than resonance, things are more or less out of step, and the consequent confusion reduces the amount of current that can be handled.

A check with a voltmeter across the capacitor and the inductance reveals

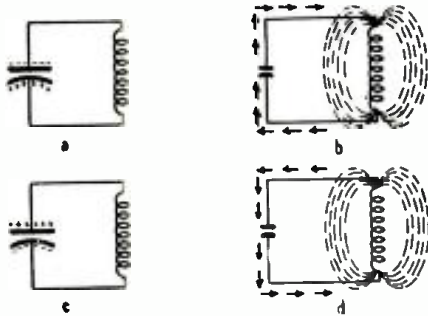

Fig. 4—The electron flow in a tuned circuit. that a considerably higher a.c. voltage is found across each than across the combination of the two. To understand how one plus one can equal considerably less than two, remember that, although the current through a purely resistive resonant circuit is in phase with the applied voltage, this same current is leading the voltage across the capacitor by nearly 90 degrees and lagging the voltage across the inductance by approximately the same angle—just another way of saying that the voltages across the capacitor and the inductance are nearly 180 degrees out of phase with each other. Voltages 180 degrees out of phase are “bucking” voltages, working directly opposite to and cancelling the effects of each other. That is why the total voltage across the combination of capacitor and inductor can be less than the voltage measured across either one of them.

Let us consider an example: Suppose, as is shown in Fig. 5 a 1-henry coil and a 7.03- $\mu$ f capacitor are connected in series across a generator that puts out 100 volts at 60 cycles. Suppose, too, that the total ohmic resistance of choke and condenser is 100 ohms. Using the formulas  $X_L = 2\pi fL$  and  $X_C = \frac{1}{2\pi fC}$  to find the reactances of the coil and capacitor, respectively, we discover (by no coincidence!) that each has, at 60 cycles, a reactance of about 377 ohms. Since these two resonances cancel each other, only the 100 ohms of resistance impedes the flow of current through the circuit.

Whipping out and applying our trusty Ohm's Law ( $I = E/R = 100/100$ ), we learn that our 100-volt generator will send 1 ampere of current surging back and forth through the circuit. But the voltage drop across a capacitor or coil is equal to its reactance in ohms multiplied by the amperes of current flowing through it: thus we discover

that we would have about 377 volts across our capacitor and another 377 volts across our inductance. Believe it or not, but you can try it with any 100-volt a.c. source and a 1,000-ohm-per-volt meter!

Assuming that what we want to do with our series tuned circuit is to obtain a maximum flow of current through it, our best circuit is the one with the least resistance. Since the major portion of this resistance below 30 megacycles is contained in the coil, it follows that a high-inductance, low-resistance coil is ideal. The symbol  $Q$ , used to indicate this measure of merit of a coil is defined as the ratio between the coil's reactance and its resistance. The  $Q$  of the coil used in our illustration would be equal to 377/100 or about 3.75. Coils used in radio work may have  $Q$ 's exceeding 100.

### Parallel circuits

When our variable-frequency generator is hooked across the parallel tuned circuit of Fig. 2, we find that at a low frequency the inductive reactance of the coil forms a low-impedance path across the terminals. At a high frequency, the capacitive reactance of the condenser does the same thing. However, there is one frequency, again the resonant frequency, at which the two reactances are equal; at this frequency there is a high impedance to the flow of current from the line through the parallel tuned circuit.

Fig. 6 shows the impedance of a parallel tuned circuit. Note that it is almost an exact replica of the current-curve of the series tuned circuit.

The *why* of this sharp increase in impedance at resonance is wrapped up in the fact that the currents through the inductive and capacitive branches of our parallel tuned circuit are 180 degrees out of phase with each other. While the current is flowing from top to bottom through the coil, it is flowing from bottom to top through the capacitor, and *vice versa*. Actually the current is oscillating back and forth through the tuned circuit like the balance wheel of a watch, and this current and the voltages it produces are so timed that very little current from the line is able to flow through the circuit.

Assume that the generator has built up a negative peak voltage on the top plate of the capacitor in Fig. 2. As this voltage begins to subside, the capacitor charge starts to force current through the coil and develops an expanding magnetic field about that coil. During the next quarter cycle, when the line voltage begins to build toward a negative peak voltage on the bottom plate of the capacitor, the collapsing magnetic field of the coil forces a counter e.m.f. of its own onto this plate to buck out the voltage from the line. When the line voltage reverses itself and rushes around to the top plate again to see if it cannot get its foot in the door there, this counter e.m.f. is right back there to slam the door in its face; and as long as the circuit

is tuned to resonance, this exasperating voltage produced by the oscillating current within the tuned circuit is never caught napping.

The whole thing is similar to, and about as frustrating as, patting a mirror. No matter how nimbly you move, that other guy behind the glass always meets your outstretched palm with the flat of his own hand!

There are just two ways to cross up this bar-the-door-they're-coming-in-the-window routine: One is to detune the circuit and thus throw off the timing of the oscillating current so that the line voltage can sneak some current through. The other is to weaken the voltage produced by the oscillating current by placing a resistor across the circuit. The current that flows through the resistor is dissipated in the form of heat and so is “lost,” and the remainder of the circulating current is not sufficient to produce a voltage great enough to buck out the line voltage. This effectively reduces the resonant impedance peak of the circuit as is shown in Fig. 6. Sometimes we deliberately “load” a parallel tuned circuit with a resistor to make it present a more uniform (but lower) impedance to an extended range of frequencies.

While an unloaded parallel tuned circuit draws very little current from the line, the circulating currents inside the circuit itself are usually high, being many times the line current.



Fig. 5—Series circuit resonates at 60 cycles.

To review: in a series tuned circuit at resonance, the current and the applied e.m.f. are in phase; the current is maximum; the impedance is minimum, equal to the ohmic resistance, and resistive; the voltage across the inductor is equal and opposite in sign to that across the capacitor; and both of the latter voltages are greater than the applied e.m.f.

In a parallel tuned circuit at resonance, the impedance is maximum and resistive; the current from the line is minimum; the circulating currents between the capacitor and coil are high.

Perhaps their use as wave traps best illustrates the fundamental differences between the actions of the two circuits. Fig. 7 is an example. At 7-a, the series trap forms a very low impedance path between the antenna lead and the ground at its resonant frequency, while it presents a higher impedance to all other frequencies and forces them to pass through the antenna coil to reach ground. At 7-b the parallel tuned circuit in series with the antenna lead says “thou shalt not pass” to its resonant frequency, but it presents little or no obstacle to the passage of all other frequencies. The kind of guy who wears both belt and suspenders and never wants to be half safe could use both of



these circuits to get rid of a single unwanted signal. (Not a joke—sometimes it's necessary!—*Editor*.) The parallel circuit would keep most of it from reaching point X, and the series circuit would bypass the rest to ground.

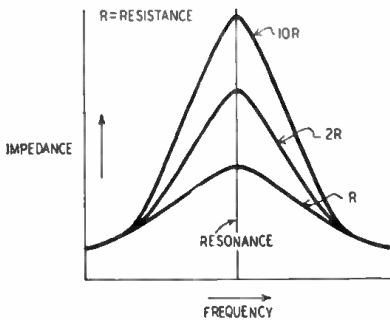

Fig. 6—Resistance lowers Q of parallel tank.

To "tune" our tuned circuit, or vary its resonant frequency, we must vary either the inductance or the capacitance. Mechanically, it being usually easier to use a variable capacitor with a fixed inductance, that is the most common type of tuned circuit. However, by changing the core material of the coil, we can vary its inductance (as pointed out in Part III), and therefore "sluggish" circuits are becoming more and more common. A coil tuned with a movable slug is shown second from right in the accompanying picture at the bottom of page 47.

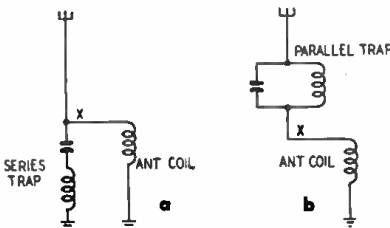

Fig. 7—Tuned circuits employed as wavetraps.

The thing to keep clearly in mind is that tuned circuits permit you to single out a particular frequency and lead it down an irresistible path or to throw an insurmountable barrier across its way. You are the boss!

**C-R TUBE DISPOSAL**

"Use discretion in disposal of picture tubes" warns *Sylvania News* in a recent issue. The service technician can be held legally liable if some child or curious adult comes to grief through investigating or playing with tubes that have been discarded in such a way that they remain a menace to safety.

The safe and easy way to dispose of a large cathode-ray tube is to pack it in its own or a similar carton, seal it up, then drive a heavy tool or steel or iron rod through the bulb end or side of the case. Then you have just so much broken glass to deal with, and there is no danger from flying particles.

Much has been written about the proper and careful handling of "live" television viewing tubes. This is the first item we have seen on the disposal of dead ones, an operation which will be very important in a year or two.

# Industrial Radio Service

THE Lamson Company of Binghamton, New York, is a typical industrial plant employing 450 men and women. In its office may be found tape and wire recorders, and throughout its plant are strategically located loudspeakers coupled to a 50-watt PA and intercommunication system. A complete miniature broadcasting studio from which employees may hear music, speech, and entertainment is an essential feature of everyday plant operations.

Jack Rose, service technician of Binghamton, handles repair and maintenance of all radio apparatus in the plant. His charge of \$200 yearly includes 52 weekly check-ups. Once a week Rose checks all office recorders, the plant PA unit, and a disc recorder which is used by employees to wax birthday and anniversary greetings, which they take home. In addition to the \$200 retainer fee he makes an additional \$25 yearly charge covering tubes and components.

Rose has more than 11 factories of varying sizes on his weekly check-call list. All factories sign a contract which calls for weekly inspections and repairs or replacements when necessary. Rose calls these contracts "radio insurance industrial plant policies."

The Winters Radio Service of Salt Lake City, Utah, is interested in industrial plant employees.

All employees of any Salt Lake City plant may obtain a "factory worker radio service certificate." This certificate entitles the holder to three inspections yearly at quarterly intervals for the sum of \$15, regardless of the model radio owned. Radios are guaranteed to play in the periods between such inspection calls and when necessary emergency inspections are made.

Employees are also privileged to have ailing radios repaired at a \$1.25-per-hour service rate, plus prevailing replacement part costs, less a 15% discount if radios are left at the plant for pickup and return. Plants provide a small room where sets may be left and tagged with the owner's name. Employees receive a statement with returned radios and leave the payments at the factory payroll office in a sealed envelope addressed to the radio technician. Payment must be made within one week of the radio's return or the set owner is placed on the black list which makes him ineligible for credit on future service jobs.

The Winters Radio Service has 34 plants of varying size in the Salt Lake City region at which its service truck calls daily to make pickups and returns. According to this organization, radio service problems yield handsome dividends indeed.

The Pacific Industrial Radio Service of San Francisco, California, is especially interested in installation and maintenance of industrial plant juke boxes. This radio service concern installs juke boxes in workers' lounges and relaxation rooms. Each week technicians check the juke boxes and install new records. Such factory juke boxes require no nickels. Employees merely select a recording when they are in a mood for music. Pacific Industrial charges factories a flat fee for the juke box plus a weekly service fee which includes a change of records. They purchase old units from juke box operators, recondition them, and install them in factories. At present they have a factory juke-box route which includes 34 industrial plants.—*Couklin*

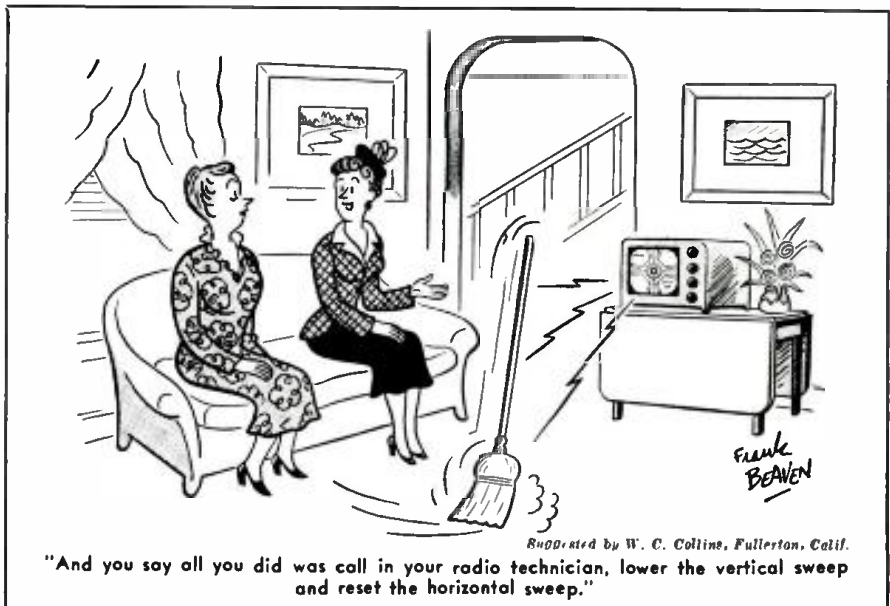

"And you say all you did was call in your radio technician, lower the vertical sweep and reset the horizontal sweep."

# Radio Set and Service Review



**New Zenith FM set has sensitivity, stability**

**M** EASURING about 6½ x 12 x 5¼ inches in its plastic cabinet, Zenith's model 7H918 (7FO3 chassis) looks like any small bedside receiver and is as easy to operate. Instead of snaps, pops, and crackles along with your soap opera, however, you'll hear only blissful silence in the background, for this is an FM receiver of unusual sensitivity with an Armstrong limiter-discriminator circuit.

Using the built-in power-line connection as an antenna, the receiver performed very well in the middle of New York. Outside of the city it showed a sensitivity superior to most other FM receivers and tuners tried and its selectivity was very nearly as good. Tone—always a matter of personal taste—appeared to the reviewers slightly over-bassed and highs were attenuated, though not missing altogether. Service technicians and technically minded buyers, however, will have little difficulty in adjusting tone to suit themselves, as outlined farther on. The set is very easy to tune and shows no warm-up drift.

As the circuit schematic shows, seven tubes are used; all are miniatures. The 12BA6 is an untuned r.f. amplifier. One side of the a.c. power line is normally

tied to the 12BA6 grid through 7.5- and 100-µuf capacitors, making the power line itself act as antenna. Reversing the plug in the sockets seems to make a difference on some stations, as does the position of the line cord. Normally it should be stretched out. An outside antenna may be connected to the set with 300-ohm line. The blue lead from the power lead is disconnected from the F screw terminal on the back of the cabinet, and the 300-ohm line is connected to the F and G posts.

The 12AT7 dual-triode is the converter. One triode is the oscillator, its signal being coupled to the other grid through the 0.68-µuf capacitor. The two tuned circuits—oscillator and converter—are permeability-tuned. The movable slugs are terminated in semiflexible rods which move between two rollers above the chassis. One roller is turned by the dial cord; the other is free but is pushed tightly against it by a spring. The effect is something like a clothes wringer.

There are two stages of permeability-tuned i.f. at 10.7 mc and a single Armstrong limiter. The 19T8 is the discriminator and first audio tube. This tube is a duo-diode-triode combined with a single diode. The single diode and one

of the diodes associated with the triode are used for detection. The 35B5 output stage feeds a 4-inch PM speaker.

There are two tone-control networks in the audio section. The first is the familiar .02-µf capacitor across the primary of the output transformer. Removing this or substituting a smaller capacitance will restore the highs and

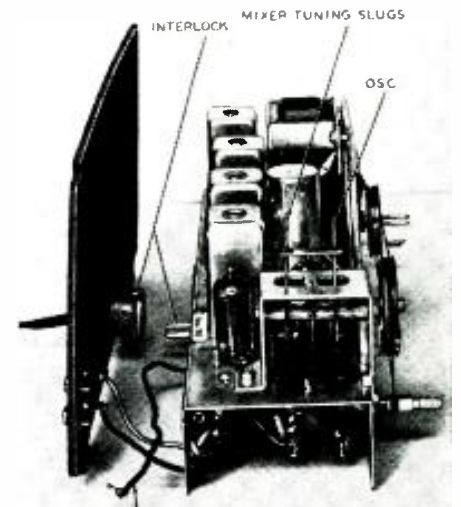

Chassis photo shows tuner, safety interlock.

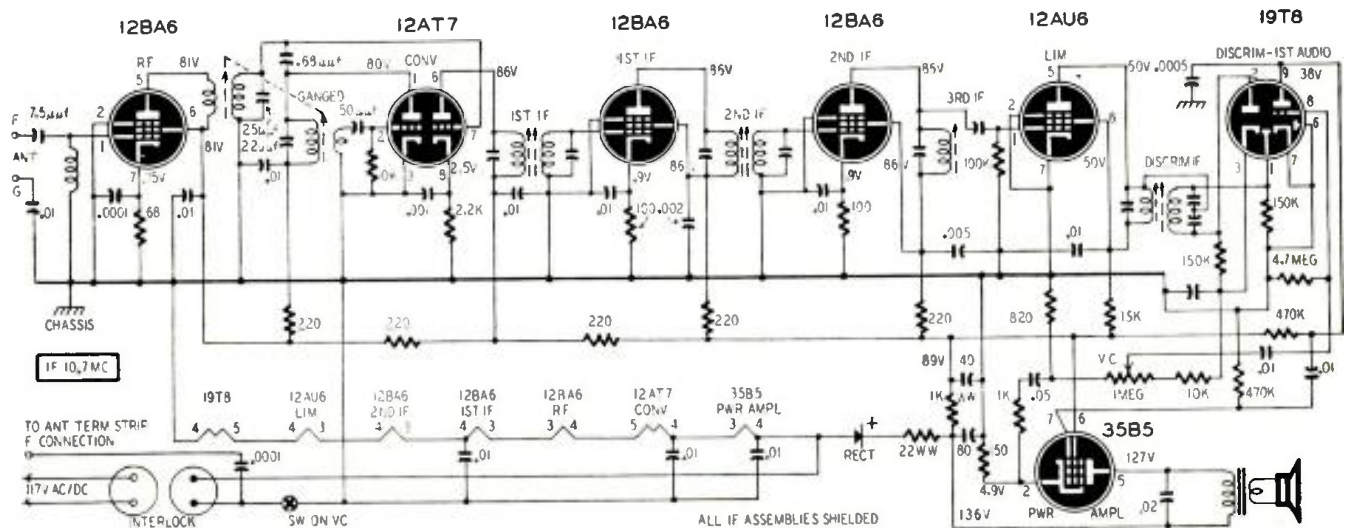

Complete circuit schematic of the Zenith 7FO3 FM receiver chassis. The single limiter does a good job, even in a noisy New York location. **RADIO-ELECTRONICS for**



# ALLIED'S NEW **FREE** 1950 RADIO CATALOG

**196 VALUE-PACKED PAGES**

*Send for it now!*

**ALL THE LATEST RELEASES**  
**BIG MONEY-SAVING VALUES**



## Get Radio's Leading Buying Guide

Here's the Buying Guide to everything in radio for everyone in radio! Preferred by expert service technicians, engineers, sound men, Amateurs, builders and experimenters—it's packed cover to cover with the world's largest selections of quality equipment at lowest money-saving prices. See the latest in TV and home radio receivers; radio-phonos with new three-speed changers; new Sound Systems, P.A. equipment and high-fidelity sound components; recorders and accessories; full selections of newest Amateur receivers and station gear; test instruments; builders' kits; huge listings of parts, tubes, tools, books, diagrams.

ALLIED gives you every buying advantage; speedy delivery, expert personal help, lowest prices, assured satisfaction—plus the most liberal Time Payment plan in radio. Get the new 1950 ALLIED Catalog. Keep it handy—it will save you time and money. Send today for your FREE copy!

**LARGEST STOCKS • QUICK, EXPERT SERVICE**

Send for your **FREE** copy of  
**Radio's Most Complete Catalog**  
*Use the coupon below—NOW!*

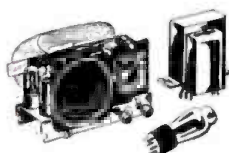

### WORLD'S LARGEST STOCKS

Everything in radio for everyone in radio! ALLIED's huge stocks are the world's largest, including complete lines of all leading makes of parts and equipment. Get everything you need from one dependable centralized source—ALLIED RADIO!

### TELEVISION & HOME RADIOS

See ALLIED's outstanding selection of new Television sets, new table model radios, FM-AM combinations with new Three-Speed Automatic Changers. Save on these radio models—the choice of experts!

### AMATEUR STATION GEAR

You'll find everything you need for your shack in the new ALLIED Catalog. See all the latest releases in receivers, transmitters, parts, station equipment—the biggest and most complete listings in Ham radio!

### NEW SOUND EQUIPMENT

Packaged, ready-to-use Sound Systems; amplifiers guaranteed for one full year; high-fidelity sound components; everything in speakers, mikes, P.A. accessories, intercom and recording equipment—ALLIED RADIO is headquarters for Soundmen!

Radio's Leading Buying Guide

THE WORLD'S  
LARGEST  
RADIO  
SUPPLY  
HOUSE . . .



ALLIED RADIO CORP.  
833 W. Jackson Blvd., Dept. 2-J-9  
Chicago 7, Illinois

Send FREE New 1950 ALLIED Catalog.

Name.....

Address.....

City.....Zone.....State.....



## DON'T BUILD ANY TELEVISION KITS!

—When you can pick up a factory wired and tested 630TV Television Set, complete with tubes, ready to operate—at the same price as a kit!—Why fuss or have headaches?

This is the famous RCA type 630TV chassis which has proved to be superior to anything yet developed. We need not describe the 630TV chassis—you already know about it. The design and operation is excellent—and it's fully guaranteed! Complete with tubes, ready for cabinet installation.—Will operate the 10", 12", 12½", 15", and 16" Picture Tubes. Price, Less Picture Tube **\$157.50**  
16" Glass Tube ..... \$57.50

### AC/DC TELE-BOOSTER

#### CHECK THESE FEATURES

- Uses 3 type 6AK5's in an extremely stable and efficient wide-band amplifier circuit.
- Self-contained power supply using selenium rectifier.
- Covers all television channels in use.
- Eliminates need for outdoor antennas in many locations.
- Will actually make difference between "Flat" and very bright pictures on weak stations.
- Improves receiver immunity to off-channel interference. Can be tuned to boost weak station or turned off to provide normal reception.
- Simple to install and operate, requires only external connection to receiver.
- Operates on 110 volts AC or DC. **\$16.95 ONLY**

### DUAL SPEED AC/DC PORTABLE RECORD PLAYERS

These units were manufactured for the United States Government. Used, but reconditioned for resale, at a sensationally low price. The motors are of the dual speed type—33-1/3 and 78 RPM with fully adjustable speed control and will operate on either 110 Volts AC or DC. No noisy inverters required for DC use. Smooth silent operation.

Cabinets are solidly constructed for portable use and are covered with attractive leatherette. Complete with an electrodynamic loudspeaker, built-in pickup and amplifier, just plug-in and play. Priced Ridiculously Low While They Last—Only **\$16.95**

### 5 TUBE AC/DC SUPERHET KIT

Beautiful plastic cabinet with complete parts and instructions to quickly and easily make up a sensitive 5 tube AC/DC superheterodyne broadcast radio. Plenty of volume with good tone quality is assured by the beam power stage and the PM Dynamic speaker.

All material including tubes are furnished for less than half the cost of the built up radio. Nothing else to buy. Tubes used are, 1-12SA7, 1-12SK7, 1-12SQ7, 1-50L6, 1-35Z5. Powerfully sensitive built-in loop included. Price including all tubes and cabinet. **\$8.95**

### TWO STATION INTER-COMMUNICATION SYSTEM

Radiomen—provide yourself with an additional source of income by selling and installing these high quality—low cost intercoms.

Selling Features: ● For the nursery (baby sitting) or sickroom ● In private homes—room to room—garage to house—basement to attic, etc. ● Busy businessmen ● Ideal for use in television antenna installation and servicing—instead of unhandy earphones ● Simple installation—only 2 wires to connect ● Housed in an attractive walnut case, 1 master and 1 slave station, complete with tubes.

Price cable. **\$11.95**  
Extra for 50 feet twin-lead —\$1.00

### MODEL NFRD—RADIO NOISE FILTER

If it doesn't work, send it back!!

We absolutely guarantee that our Model NFRD will eliminate all line noises when properly connected to radios, television sets, short wave sets, motors, electric shavers, refrigerators, vibrators, oil burners, transmitters, and all other sources of interference. This unit will carry up to 12 amperes or 1¼ KW of power and may be used right at the source of interference or at the radio.

Small size only 3" x 1½" x 7/8". **\$1.95**  
Very low price only EACH

Satisfaction guaranteed on all merchandise.  
All prices F.O.B. New York City  
WRITE FOR FREE CATALOGUE T9

## RADIO DEALERS SUPPLY CO.

154 Greenwich St. New York 6, N. Y.

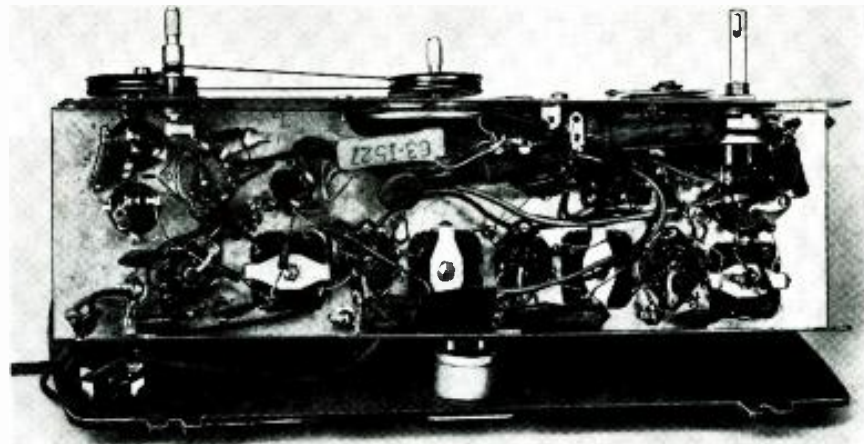

Service technicians should appreciate the lack of crowding under the receiver's chassis.

give a somewhat more brilliant tone, though it will also allow noise to enter the speaker and thus necessitate more precise tuning.

The other is a negative feedback arrangement between the cathode of the power-amplifier and the grid of the first audio. The percentage of feedback is limited by connecting the loop to an 820-ohm resistor at the bottom of the volume control. Because of the .05- $\mu$ f capacitor and 1,000-ohm resistor in the loop, the feedback consists substantially of frequencies above 3,000 cycles. To reduce the bassiness this causes, values for the resistor and capacitor may be changed. Omitting the network entirely, however, causes an unpleasing lack of bass.

Zenith, apparently conscious of the danger inherent in a.c.-d.c. chassis, has so designed the set as to make it impossible to touch anything connected to the chassis unless the back is removed. (The back has a warning stenciled on it as well.) The controls are insulated. Moreover, when the back is removed, a socket attached to it disconnects from a male plug on the chassis so that no line voltage is con-

nected to the set—an interlock arrangement, in other words, like those found on television receivers. This is a very unusual and commendable feature as it makes the set genuinely shockproof. Even the screws holding the chassis to the cabinet are not underneath as in the usual receiver. They are inside, where they cannot be touched unless the back is removed.

The receiver is aligned in the usual manner, preferably with an FM generator and oscilloscope. Alignment frequency for the r.f. section is 98 mc. The tuning slugs for the oscillator and mixer coils may be adjusted after melting, with a hot iron, the cement which prevents them from turning. A drop of speaker cement should be put on each after alignment to hold it in place.

A .05- $\mu$ f capacitor should be connected in series with the signal generator when aligning the i.f.'s and a 270-ohm resistor when aligning oscillator and mixer.

This receiver cannot, of course, reproduce the full tonal possibilities of FM. As a substitute for the usual noisy, distorting AM bedside set, however, it is ideal.

### FRINGE RECEPTION DISCUSSED AT LITTLE ROCK

Members of the Greater Little Rock, Ark., Radio Servicemens Association and their visitors heard Robert W. Barton, Motorola engineer, discuss "Television Reception in Fringe Areas" at their regular meeting which was held on June 17.

Mr. Barton stated that a skilled technician could do much to improve reception, particularly by the use of proper antennas. These should be stacked directional arrays—cut for the one channel on which reception is desired—rather than the broadband type. A particularly promising antenna for fringe areas, he continued, is the rhombic. Though it demands much space and must be oriented exactly both horizontally and vertically for the best results, a superior rhombic is close to being ideal for weak-signal areas.

Boosters are another useful aid, and, where transmission lines are long or signal-noise ratio bad, should be installed right up at the antenna. If two boosters are used, they should be "staggered," i.e., one tuned to the video and the other to the sound carrier. Otherwise they might tend to sharpen the signal too much, causing serious loss of picture definition.

Mr. Barton's address was followed by a short general discussion on organization problems, in which visitors from Hot Springs, whose association faces a number of difficult local problems, took an especially active part. Service technicians from three other Arkansas points (Pine Bluff, Magnolia, and Fordyce) were also present at the meeting. The total number of technicians attending was more than 30.



**MONEY BACK GUARANTEE** — We believe units offered for sale by mail order should be sold only on a "Money-Back-If-Not-Satisfied" basis. We carefully check the design, calibration and value of all items advertised by us and unhesitatingly offer all merchandise subject to a return for credit or refund. You, the customer, are the sole judge as to value of the item or items you have purchased.

**A COMBINATION**  
**20,000 OHMS PER VOLT MULTI-METER**  
**and TELEVISION KILOVOLT METER**

The New Model TV-20



The Model TV-20 operates on self-contained batteries. Comes housed in beautiful hand-rubbed oak cabinet complete with portable cover. Built-in High Voltage Probe, H. F. Probe, Test Leads and all operating instructions

**Added Feature:** Includes an Ultra High Frequency Voltmeter Probe with a frequency range up to 1,000 MEGACYCLES. When plugged into the Model TV-20, the V. H. Probe converts the unit into a negative Peak-Reading H. F. Voltmeter.

**\$39.95** NET

- Specifications:**
- 9 D.C. Voltage Ranges: (At 20,000 ohms per Volt)
    - 0-2.5/10/50/100/250/500/1,000/5,000/50,000 Volts)
  - 8 A. C. Voltage Ranges: (At 1,000 ohms per Volt)
    - 0-2.5/10/50/100/250/500/1,000/5,000 Volts
  - 5 D. C. Current Ranges
    - 0-50 Microamperes
    - 0-5/50/500 Milli-amperes
    - 0-5 Amperes
  - 4 Resistance Ranges:
    - 0-2,000 / 20,000 ohms. 0 - 2 20 Megohms
  - 7 D. B. Ranges: (A I) D. B. ranges based on ODS = 1 Mv. into a 600 ohm line)
    - 4 to +10 db
    - +8 to +22 db
    - +22 to +36 db
    - +36 to +42 db
    - +42 to +56 db
    - +48 to +62 db
  - 7 Output Voltage ranges:
    - 0 to 2.5/10/50/100/250/500/1,000 Volts

The Model 88—A Combination

**SIGNAL GENERATOR**  
**and SIGNAL TRACER**

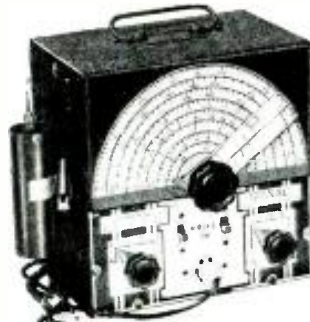

The Model 88 comes complete with all test leads and operating instructions. D.N.L.Y.

**Signal Generator Specifications:**  
 \*Frequency Range: 150 Kilocycles to 50 Megacycles. \*The R.F. Signal Frequency is kept completely constant at all output levels. \*Modulation is accomplished by Grid-blocking action which is equally effective for alignment of amplitude and frequency modulation as well as for television receivers. \*R.F. obtainable separately or modulated by the Audio Frequency.  
**Signal Tracer Specifications:**  
 \*Uses the new Sylvania IN34 Germanium crystal Diode which combined with a resistance-capacity network provides a frequency range of 300 cycles to 20 Megacycles.

**\$28.85** NET

The New Model 670



**SUPER METER**

**A Combination VOLT - OHM - MILLIAMMETER plus CAPACITY REACTANCE, INDUCTANCE and DECIBEL MEASUREMENTS.**

- D.C. VOLTS: 0 to 7.5/15/75/150/750/1500/7500
- A.C. VOLTS: 0 to 15/30/150/300/1500/3000
- VOLTS: 0 to 15/30/150/300/1500/3000
- D.C. CURRENT: 0 to 1.5/15/150 ma.; 0 to 1.5 Amps.
- RESISTANCE: 0 to 500/100,000 ohms. 0 to 10 Megohms.
- CAPACITY: 0.01 to .2 Mfd., 1 to 1 Mfd. (Quality test for electrolytics.)
- REACTANCE: 700 to 27,000 Ohms; 13,000 Ohms to 3 Megohms
- INDUCTANCE: 1.75 to 70 Henrys; 35 to 8,000 Henrys
- DECIBELS: -10 to +18, +10 to +38.

The model 670 comes housed in a rugged, crackle-finished steel cabinet complete with test leads and operating instructions. Size 5 1/2" x 7 1/2" x 3".

**\$28.40** NET

The New Model TV-10 **TUBE TESTER**



The Model TV-10 operates on 105-130 Volt 60 Cycles A.C. Comes housed in a beautiful hand-rubbed oak cabinet complete with portable cover.

**\$39.50** NET

- Specifications:**
- \* Tests all tubes including 4, 5, 6, 7, Octal, Lock-in, Peanut, Bantam, Hearing-aid, Thyatron, Miniatures, Sub-Miniatures, Novals, etc. Will also test Pilot Lights.
  - \* Tests by the well-established emission method for tube quality, directly read on the scale of the meter.
  - \* Tests for "shorts" and "leakages" up to 5 Meg-ohms.
  - \* Uses the new self-cleaning Lever Action Switches for individual element testing. Because all elements are numbered according to pin-number in the RMA base numbering system, the user can instantly identify which element is under test. Tubes having tapped filaments and tubes with filaments terminating in more than one pin are truly tested with the Model TV-10 as any of the pins may be placed in the neutral position when necessary.
  - \* The Model TV-10 does not use any combination type sockets. Instead individual sockets are used for each type of tube. Thus it is impossible to damage a tube by inserting it in the wrong socket.
  - \* Free-moving built-in roll chart provides complete data for all tubes.
  - \* Newly designed Line Voltage Control compensates for variation of any line voltage between 105 Volts and 130 Volts.

The New Model TV-30

**TELEVISION SIGNAL GENERATOR**



Model TV-30 comes complete with shielded coaxial lead and all operating instructions.

**\$29.95** NET

Enables alignment of Television I. F. and front ends without the use of an Oscilloscope

- Specifications:**
- Frequency Range: 4 Bands
  - No switching.
  - 18—32 Mc. 35—65 Mc. 54—98 Mc. 150—250 Mc. Audio Modulating Frequency: 400 cycles (Sine Wave). Attenuator 4 position, ladder type with constant impedance control for fine adjustment. Tubes Used: 6C4 as Cathode follower and modulated buffer. 6C4 as R.F. Oscillator. 6SN7 as Audio Oscillator and power rectifier.

The New Model 770—An Accurate Pocket-Size

**VOLT-OHM MILLIAMMETER**



(Sensitivity: 1000 ohms per volt)  
 Compact-measures 3/4" x 5 1/2" x 2 1/4". Uses latest design 2 1/2" accurate 1 Mil. D'Arsonval type meter. Same zero adjustment holds for both resistance ranges. It is not necessary to readjust when switching from one resistance range to another. This is an important time-saving feature never before included in a V.O.M. in this price range. Housed in a round-cornered, molded case. Beautiful black etched panel. Depressed letters filled with permanent white, insures long-life even with constant use.

**Specifications:**

- 6 A.C. VOLTAGE RANGES: 0-15/30/150/300/1500/3000 volts.
- 150/750/1500 volts.
- 6 D.C. VOLTAGE RANGES: 0-7.5/15/75/150/750/1500 volts.
- 4 D.C. CURRENT RANGES: 0-1 1/2/15/150 Ma. 0-1 1/2/15 Amps.
- 2 RESISTANCE RANGES: 0-500 Ohms. 0-1 Megohm.

The Model 770 comes complete with self-contained batteries, test leads and all operating instructions.

**\$13.90** NET

20% DEPOSIT REQUIRED ON ALL C.O.D. ORDERS

**GENERAL ELECTRONIC DISTRIBUTING CO.** Dept. RC-9, 98 PARK PLACE NEW YORK 7, N. Y.

# Operation on 160 METERS

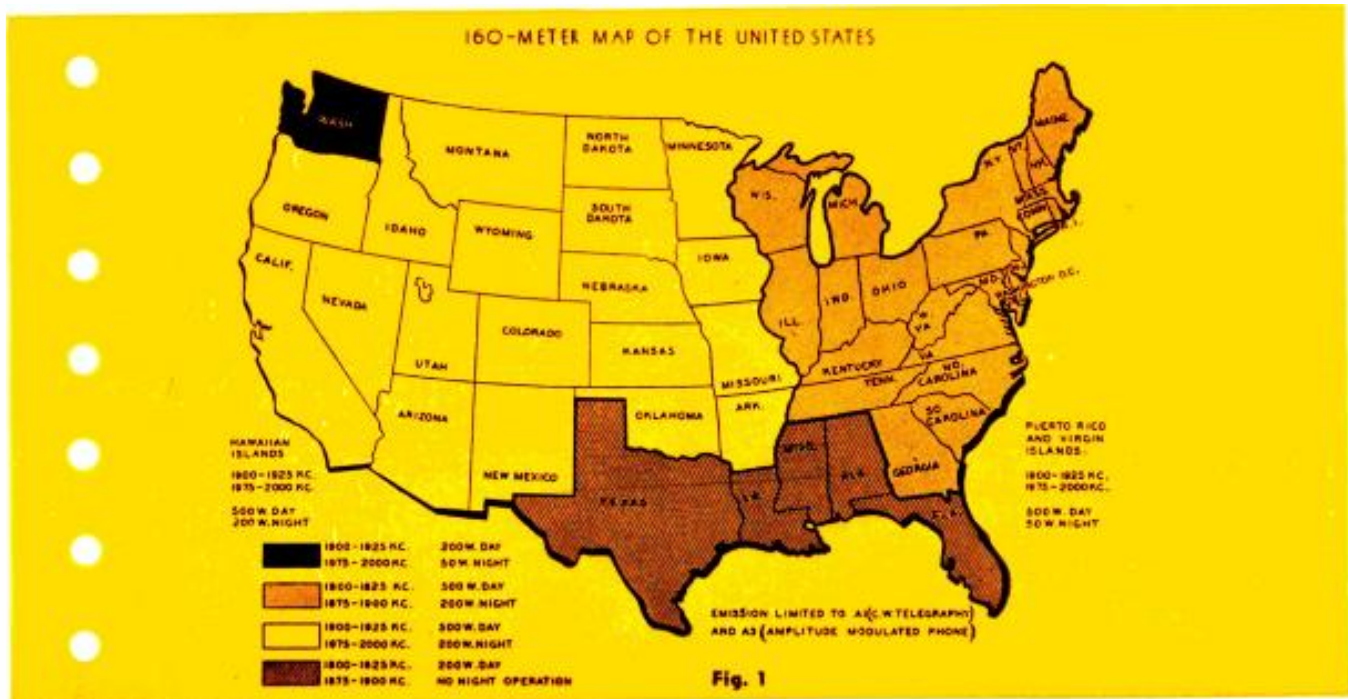

By **RUFUS P. TURNER, K6AI\***

**W**ITH the reopening of the 160-meter band a new thrill awaits the postwar ham as well as the oldster who never got around to trying this band before the war. Reoccupation of 160 may also relieve some of the congestion in the higher-frequency bands.

Before the war, the 160-meter band was a cozy meeting place for rag chews, especially among class-B phone operators. It also was a natural for local code-practice broadcasts. Excellent for short-haul traffic and for 500-mile (or better) nighttime contacts, 160 was known occasionally to uncover some interesting domestic DX.

Operation on 160 meters introduces a few problems peculiar to itself. For example, tank circuits are much larger than on the higher frequencies, and BCL is of special concern because of the comparative nearness of 160 to the standard broadcast band. Transmitters must work straight through (that is,

oscillator, buffer, and final amplifier must all be on the same frequency—no doublers), and half-wave antennas are inconveniently long so that shorter antennas must be employed in most cases.

Moreover, the new 160-meter regulations bring further special requirements into the picture: The entire pre-war band has not been reallocated; certain portions of it are assigned to specific geographic localities. The operator must provide satisfactory means for reducing the power input to his final amplifier to the specified nighttime power for his particular locality. (In one geographic section, nighttime operation is prohibited altogether.) There is a limitation on daytime power, as well. Nowhere is the usual 1-kilowatt power input permitted. Emission is limited to A1 (pure c.w.) and A3 (amplitude-modulated phone). The new band is shared with the vital Loran navigational aid, and no interference may be caused to that service.

### What frequency and power?

The map (Fig. 1) will enable you to

determine quickly the legal operating conditions for your locality—which 160-meter frequencies may be employed where you operate your station, and what daytime and nighttime power inputs you may use.

For example, if you live in Kansas, you may use only frequencies between 1900 and 1925 kc and between 1975 and 2000 kc, and you may use 500 watts in the daytime but must reduce your power to 200 watts at night. If you live in the State of Washington, on the other hand, you may use the same frequencies but may run only 200 watts during the day and must reduce to 50 watts at night. In New York, your frequencies would be 1800 to 1825 kc and 1875 to 1900 kc, and your power allotment is 500 watts days and 200 watts nights. *Night begins at official sunset, local standard time.*

### How large a tank?

After the war, coil manufacturers dropped 160-meter coils from their catalogues because the demand for them had disappeared. They may be expected to reappear soon on the market. In the

\*ex WIAY.



ALARM INDICATOR RECORD

*He can see a thousand miles*

TIME RECEIVED	A P	BY	PROUBLE FOUND
SENDING OFFICE			
RECEIVING OFFICE	DATE OK	TIME	A P BY

SYNCHRONIZATION - START					CA FAIL SEND CKT.		STATION IDENTIFICATION				
ON	ON	OFF	ON	ON	CHAN. 1 SECT						
SYNCHRONIZATION - STOP					FUEL GAS LOW						
ON	ON	OFF	ON	ON							
FUSES		24-VOLTS		ABS							
DISCH.	DIST.	H-L VOLT	REG. FAIL	24V 130V	48V						
POWER CONTROL PANEL FAILURE											
201-202W	203-204W	205-206W	207-208W	201-202E	203-204E						
ALT. CONT. BAY - NO VOLT. OUT.			NO VOLT. - TRAN								
201 202	203 204	205 206	207 208	201 202	203 204						
RECT. FAIL 24/130V	48 V H-L VOLT	RECTIFIER - INVERTER FAIL									
		NO. 1	NO. 2	NO. 3							
64 KC PILOT ALARM AT NON-SW. MAIN						3096 (WKG. LINE) PILOT AT SW. MAIN					
201	202	203	204	205	206	207	208	201 203	205 207	202 204	206 208
2064 KC PILOT ALARM AT NON-SW. MAIN						3096 (SP. LINE) PILOT AT SW. MAIN					
201	202	203	204	205	206	207	208	201 203	205 207	202 204	206 208
3096 KC PILOT ALARM AT NON-SW. MAIN						SP. LINE FAIL AT SW. MAIN					
201	202	203	204	205	206	207	208	201 203	205 207	202 204	206 208
TOT. LINE FAIL AT SW. MAIN				AUTO. SWITCH AT SW. MAIN				AUTO. SW. LOCKED AT SW. MAIN			
201 203	205 207	202 204	206 208	201 203	205 207	202 204	206 208	201 203	205 207	202 204	206 208

CARRYING hundreds of telephone calls, coaxial cable runs through many lonely miles. Far from towns and people, master amplifying stations stand guard with a new automatic alarm system developed by Bell Telephone Laboratories.

At a city terminal, the man on duty makes a check by laying a transparent log sheet over a glass window, and dialing a master station hundreds of miles away. At once the station begins to give an account of itself, lighting lamps under the log sheet to report any abnormal operating condition before it becomes an emergency.

But when something happens that threatens serious trouble, the apparatus acts at once — maybe by switching in a spare coaxial — and calls a distant test board by ringing a bell. Sometimes he can take further steps by remote control; if not, he knows exactly how to brief the nearest repair crew.

With this new alarm system, maintenance men need not be stationed at isolated points, just waiting for something to happen. Instead, they live in their home communities. This makes for better work . . . and better telephone service.

**BELL TELEPHONE LABORATORIES** EXPLORING AND INVENTING, DEVISING AND PERFECTING, FOR CONTINUED IMPROVEMENTS AND ECONOMIES IN TELEPHONE SERVICE.



meantime, prospective 160-meter constructors will want to wind their own coils and start operation without delay.

If you already have a 100- $\mu$ f tuning capacitor in your transmitter, you will need a 100-microhenry coil to hit 1800 kc (the lowest currently assigned 160-meter frequency) with the capacitor set to three quarters maximum. If your tuning capacitor is 50  $\mu$ f, your coil must have an inductance of 210 microhenries. Both of these combinations will cover all four sections of the new 160-meter band. You may determine the number of turns needed for either of these inductance values from any of the inductance tables, charts, or graphs appearing in the radio handbooks, or use the following equation:

$$N = \sqrt{\frac{3d + 9l \times L}{0.2d^2}}$$

where N = the required number of turns, d = diameter of the coil (inches), l = length of the coil (inches) and L = the desired inductance (microhenries).

For low-powered, single-ended oscillator, buffer, and final amplifier stages (using tubes up to and including type 6L6), the 100- $\mu$ h coil may be made by

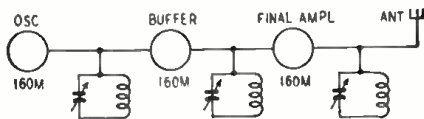

Fig. 2—Buffer is between oscillator and p.a.

close-winding 71 turns of No. 22 enameled wire on a 1½-inch-diameter form. The 210- $\mu$ h coil consists of 102 turns of No. 25 enameled wire, close-wound on a 1½-inch-diameter form. Coils for higher-powered stages (using tubes from type 807 up) require heavier wire, the size depending upon the plate power input, and accordingly will require larger coil diameters and winding lengths. To determine the number of turns needed in these coils, first decide upon the size of wire which must be used and the maximum length and diameter you can accommodate in the stage in which the coil is to be used; then substitute these diameter and length values together with the desired inductance figure in the equation above.

A quick expedient is to put your present 80-meter tank on 160. This may be done by connecting an auxiliary fixed capacitor (air or vacuum type) in parallel with your present 80-meter tuning capacitor. The capacitance of the auxiliary unit must be equal to three times the capacitance of your 80-meter tuning capacitor. Connections must be made with short, heavy leads.

**Recommended lineup**

A 160-meter transmitter must be operated straight through; that is, every stage must be on the same frequency as the radiated signal. If a doubler were included anywhere in the 160-meter rig, the preceding stage would have to operate between 900 and 1000 kc. in the standard broadcast band.

We cannot recommend this, since bitter experience indicates that even the best boxed-up, broadcast-band amateur oscillator can, and usually does, interfere with nearby broadcast receivers.

When operating straight through, it is advisable to employ a tuned buffer stage between the oscillator and final amplifier (see Fig. 2), especially when the final amplifier is modulated. And it is good practice to shield the stages from each other. A flat, vertical, sheet-metal baffle plate usually will provide sufficient shielding.

If the buffer stage is a triode, it must of course be neutralized. However, this introduces very little inconvenience, since generally it is easier to neutralize in the 160-meter band than at the higher amateur frequencies. Screen-grid tubes, such as the 807, will require no neutralization in buffer stages, provided they are mounted in tube shields and their grid and plate circuits shielded from each other. They do have a marked tendency to take off on their own at higher frequencies unless parasitic suppressor resistors are connected in their control-grid (and often plate) leads.

Either a crystal oscillator or v.f.o. may be employed on 160. Like 160-meter coils, inexpensive 160-meter crystals have not been available in any profusion on the postwar market. But their reappearance may be expected within a short time. If a v.f.o. is employed, the tunable oscillator stage must be followed by one or two buffers (or untuned class-A isolator stages) in addition to the regular buffer stage of the transmitter. This is to provide sufficient isolation. In a straight-through circuit, there is a pronounced tendency for modulation or keying in succeeding stages to react upon the oscillator frequency unless fully isolated.

Accurate frequency-measurement facilities must be available if a v.f.o. is used on 160. Only by knowing the oscillator frequency closely can the operator be sure of keeping within the limits of the channels assigned to his locality.

**Power reduction**

Since the new regulations call for reduction of power at night, adequate means must be provided for power reduction and measurement.

To reduce power: 1. Use a Variac or similar adjustable autotransformer in the primary circuit of the final plate transformer. 2. Use a final plate transformer with a tapped primary or secondary. 3. Reduce loading or excitation, or both.

Whatever method of power reduction is employed, the 160-meter operator must be sure of his power measurements. The simplest method is to measure the final amplifier plate voltage and plate current. Multiply the voltage by the current (amperes) to obtain the plate power input. If you are not sure of the accuracy of the meters used, it is far better to reduce to a lower power value than that specified by regulations.

**The antenna bugaboo**

Few amateurs have enough "house room" for a full-grown 160-meter antenna. A half-wave flat-top at 1800 kc is 260 feet long; and 1800-kc, quarter-wave, open-wire feeders are 133¼ feet long.

Several schemes found workable in the past are illustrated in Fig. 3:

Fig. 3-a. This is a popular bent-type antenna with quarter-wave in both the horizontal (flat-top) and vertical (lead-in) portions. The vertical wire must be kept as clear as possible of all buildings, trees, and other obstructions whether metallic or nonmetallic, since it is a part of the radiating system. The vertical wire must be rigidly supported. The tuning network may be an exact duplicate of the final amplifier tank.

Fig. 3-b. In this double-bent arrange-

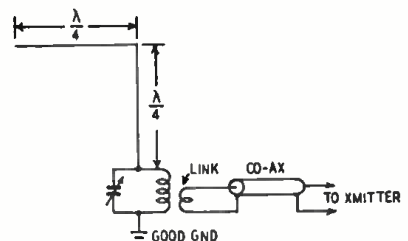

Fig. 3-a—The bent antenna for 160-meter use.

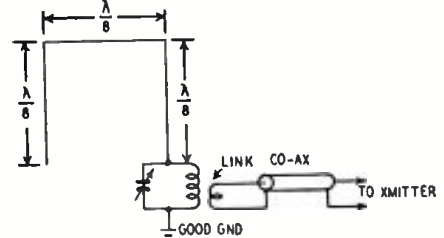

Fig. 3-b—Antenna with three bent sections.

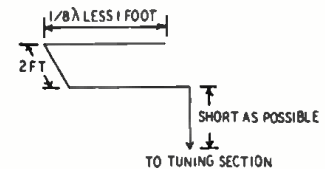

Fig. 3-c—One folded horizontal arrangement.

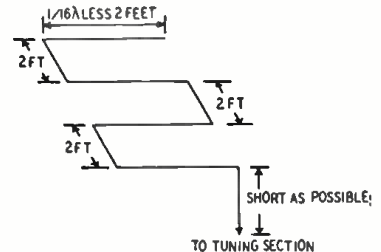

Fig. 3-d—A possible small-space arrangement.

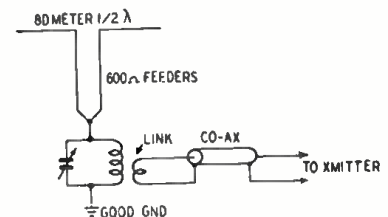
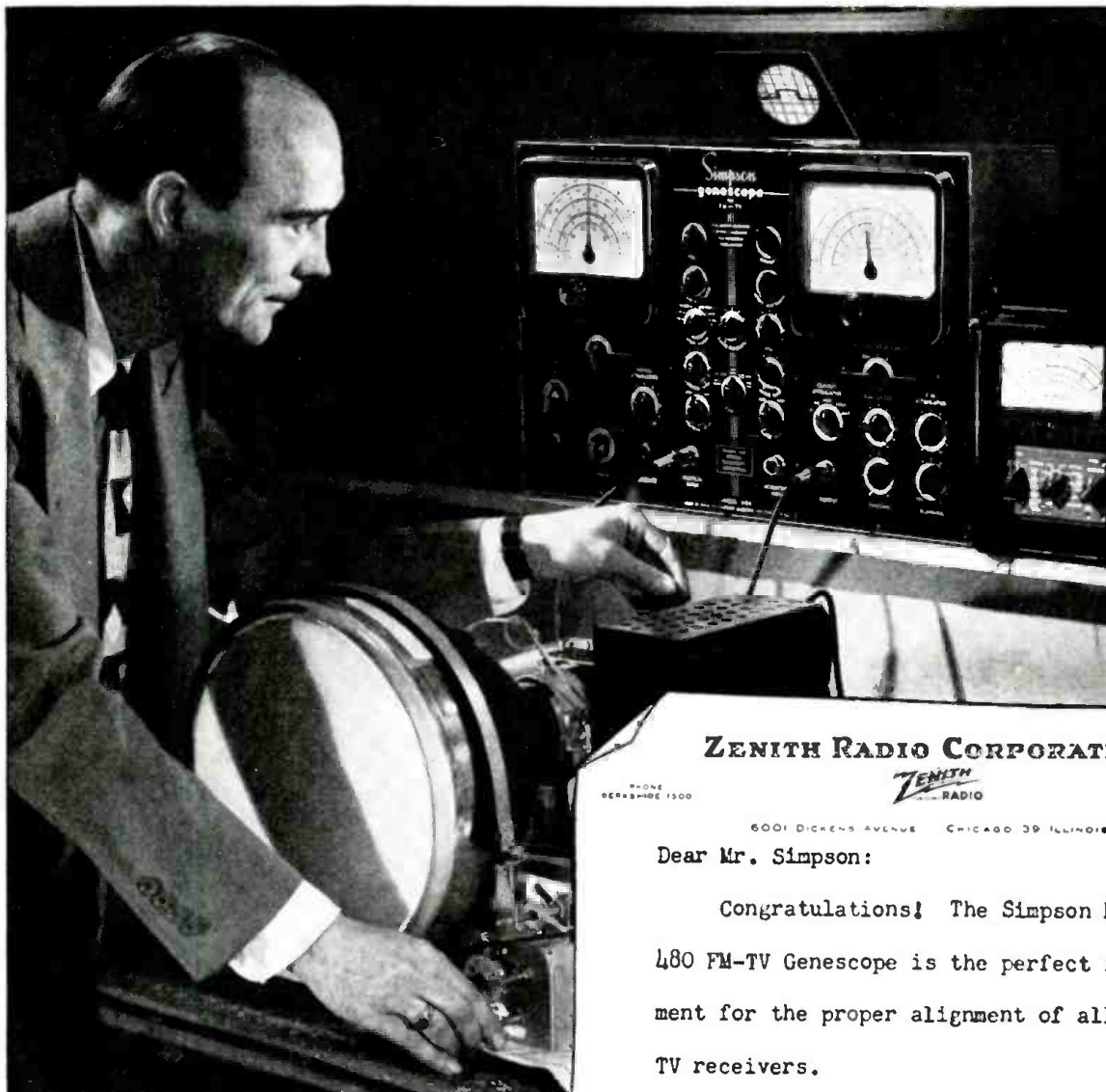

Fig. 3-e—Two-band antenna is for 80 and 160.





## ZENITH RADIO CORPORATION



PHONE  
REPAIRS—1500

EST. 1922  
ZENITH BLDG.  
MILWAUKEE

6001 DICKENS AVENUE CHICAGO 39 ILLINOIS

Dear Mr. Simpson:

Congratulations! The Simpson Model 480 FM-TV Genescope is the perfect instrument for the proper alignment of all FM and TV receivers.

In addition to providing all necessary

### says FRANK SMOLEK,

General Service Manager of Zenith

In addition to providing all necessary signal sources, the new Simpson Genescope includes a high sensitivity oscilloscope of unique advanced design, complete in every detail. Sensitivity 25 millivolts per inch. Wide band response to 3 megacycles or more. Equipped with a high frequency crystal probe for signal tracing. AM and FM oscillator sections provided with large, easy to read dials with 20:1 vernier control and 1000 division logging scale. Revolutionary, ingenious, exclusive output termination provides for various receiver impedances, either direct or through an isolating condenser.

Step attenuator for control of output.

Size: 22"x14"x7½". Weight 45 lbs. Shipping Weight 54 lbs.

DEALER'S NET PRICE complete with Test Leads and Operator's Manual \$375.00

### CHECK THESE RANGES AND YOU WILL SEE HOW MUCH THE SIMPSON GENESCOPE CAN DO FOR YOU

#### RANGES

#### FREQUENCY MODULATED OSCILLATOR

Band A—2-120 megacycles  
Band B—140-260 megacycles  
Sweep width variable from zero to 15 megacycles  
Sweep rate 60 cycles per second  
Specially designed frequency sweep motor  
Continuously variable attenuator  
Crystal calibrator—5 megacycles ± .05%  
Audio Oscillator 400 cycles

#### AMPLITUDE MODULATED OSCILLATOR

Band A—3.2-16 megacycles  
Band B—15.75 megacycles  
Band C—75-250 megacycles  
30% modulation at 400 cycles or unmodulated  
Continuously variable attenuator  
Visual method of beat frequency indication

Modern FM and TV development and servicing requires the use of test equipment made to exacting standards. With this in mind Simpson offers you the Genescope with the assurance that everything possible has been done to make it the most accurate, flexible and convenient instrument available. The Genescope will render many years of uninterrupted service and always produce accurate results.

### HERE'S THE SIMPSON—MODEL 479 TV-FM SIGNAL GENERATOR

Exactly the same circuits, ranges and functions as the Model 480, described above, with the exception of the oscilloscope.

Size 17"x14"x7½". Weight 34 lbs.  
Shipping Weight 40 lbs.

DEALER'S NET PRICE with Test Leads and Operator's Manual . . . . . \$245.00



**Simpson**  
INSTRUMENTS THAT STAY ACCURATE

### SIMPSON ELECTRIC COMPANY

5200-5218 WEST KINZIE STREET • CHICAGO 44, ILLINOIS  
In Canada: Bach-Simpson, Ltd., London, Ont.

ment, both the vertical sections must be rigidly supported and must be kept as clear as possible of all obstructions, such as buildings, trees, etc.

**Figs. 3-c, 3-d.** These folded horizontal arrangements embrace a single quarter-wave folded on itself (Fig. 3-d) and are adaptable to smaller roof space. Note that the 2-foot connecting sections are included in the total quarter-wave in each instance. Both the folded horizontal sections of these antennas and the vertical lead-in wire must be rigidly supported so that the separate sections do not move with respect to each other.

**Fig. 3-c.** This scheme enjoyed some popularity among prewar hams who commuted regularly between 80 and 160. In this scheme, the feeders (which usually are a quarter-wave long) are tied together at the transmitter end and connected to the top of a tuning unit.

While none of the antennas of Fig. 3 will give results exactly as good in every sense as a conventional 160-meter, half-wave job, each will operate sufficiently well, when properly installed and tuned, to insure 160-meter enjoyment in cases where erection of a half-wave flat-top is impossible.

**The Marconi antenna**

The quarter-wave, or Marconi, antenna was a favorite among prewar 160-meter amateurs. A quarter-wave on 160 is 130 feet, and an inverted L, 40 feet high and 90 feet long (for example) is comparatively easy to erect. (Of course, 90 feet high and 10 feet in the flat-top would be much better.)

The Marconi antenna is series-fed (Fig. 4). A coil about the size of your

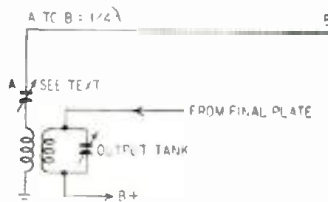

Fig. 4—Marconi antenna was prewar favorite.

output tank is used in series with the largest capacitor you can conveniently get. Anything from 365 to 1,000 μpf may be used. The coil can be tapped for further adjustment. The antenna of Fig. 3-c may also load up better if tuned as a Marconi.

The ground connection must be a good one. The best ground will be obtained by burying a number of long lengths of heavy wire as deep as possible in moist earth, preferably radiating outward from the common connection point like the spokes of a wheel. The next best ground undoubtedly is a cold water pipe to which a stout, tight connection is made. Do not, under any circumstances, attempt a ground connection by hooking to the heating system of a building, gas pipes, or buried-end downspouts.

Where a good ground is impossible, a counterpoise should be erected. In its simplest form, a counterpoise is an-

other wire strung under an aerial and a few feet above the ground. A number of parallel wires will give better results. The counterpoise need not be directly under the aerial. Many amateurs have used them in back yards and running in the opposite direction, or even on another roof, at the same height as the main aerial. Generally speaking, the poorest counterpoise is slightly better than the best ground.

A counterpoise roughly 130 feet long will put your transmitter right in the middle of a half-wave antenna system. Excellent results may be expected from such a hookup (Fig. 5), especially if the counterpoise and aerial can be run in opposite directions at the same height, making an antenna much like a standard dipole.

**Interference**

In several respects, a 160-meter station is more likely to interfere with nearby broadcast receivers than a higher-frequency amateur rig. This is due principally to closeness of the 160-meter band to the standard broadcast band. Principal forms of this interference include: *superheterodyne interference*, caused by 160-meter signals beating with the local oscillator in the receiver to set up images on the broadcast dial; *cross talk*, usually found only in poorly shielded receivers, a form of interference in which the amateur signal is tuned in and out with one or more broadcast stations, usually without whistles or "birdies"; and *spurious frequencies* caused by overmodulation of the 160-meter transmitter.

The remedy for the latter is obvious—don't overmodulate if you want to keep out of your neighbors' receivers. In each of the other cases, a good wavetrapp connected in the antenna lead of the receiver usually will remove the offending signal. A small, effective 160-meter wavetrapp may be made by connecting in parallel an 0.166-millihenry,

lattice-wound r.f. choke (such as a Miller No. 610) and a 50-μmf, miniature, variable capacitor. Wavetraps should be mounted in a shield can and installed as close as possible to the receiver antenna terminal.

The wideband video amplifier of a television receiver passes everything from zero to 4 megacycles and is a vulnerable spot for 160-meter interference. This form of TVI can be obstinate and ornery, since it enters the video channel by direct pickup rather than through the TV receiver front end, and usually is not removed by a wavetrapp in the antenna circuit. However, video amplifiers are well shielded in most television receivers and per-

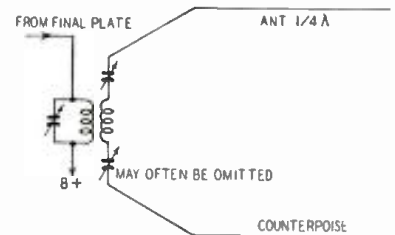

Fig. 5—A counterpoise is better than ground.

haps this type of interference will not be widespread. Harmonics of 160-meter signals may enter the video i.f. channel, this channel often being operated in the vicinity of 25 megacycles, but, according to reports of preliminary tests, they are amenable to wavetrapp action.

While on the subject on interference, a final word should be said regarding the fact that our postwar 160-meter band is *shared territory*. We rub elbows in this band with Loran, which is a vital service that can attain life and death importance. Under no circumstance can we afford to interfere with this service. Nor can we run the risk of losing 160, a fine band for local traffic, emergency work, rag chews, and a multitude of other applications.

**TRANSMISSION LINE STANDOFF**

The transmission-line standoffs manufactured by John Odegaard, Brooklyn, N. Y. are novel in construction and unusually versatile and easy to use. Each consists of a cadmium-plated, hardened-steel, flat nail and a small piece of specially punched polyethylene similar to that of which ribbon transmission line is made.

The nail is shaped much like a flooring or horseshoe nail, with small "steps" along one edge. It may be driven into wood, the mortar between bricks, or iron or aluminum television antenna mast pipes. It may be used to join the antenna mast to an extension, as shown in the photo. A lead weight back: up the pipe in this case. No drilling is necessary; the nails may simply be hammered in and through.

The top row of standoffs in the wall (see photo) shows the sequence of operations. The nail is hammered in, then one of the slots in the polyethylene strip is forced over the head. The

cable is placed beneath the flap and the strip is foiled over the cable, the other slot going over the nail head.

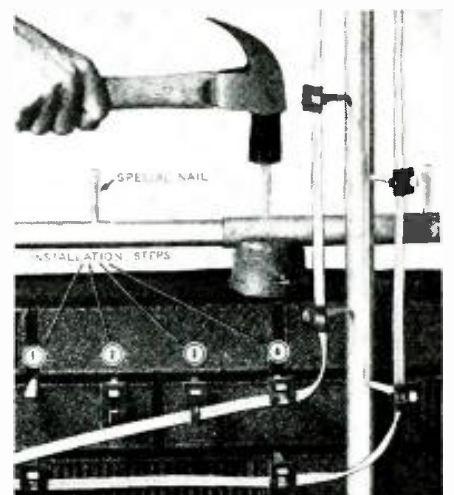

Assembly steps for the standoff are numbered.



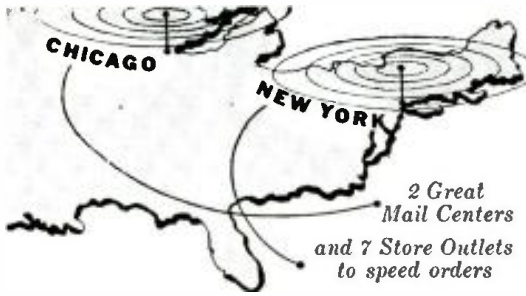

# LAFAYETTE

## ELECTRO NEWS

29 Years of Service—500,000 Satisfied Customers

# AMAZING PRICES IN NEW FREE CATALOG!

## BARGAIN DAYS

Lafayette's new low-price policy will save you big money on everything you buy in radio... parts, tools, etc. Check the values shown here—they're only a sampling of the super bargains in our catalogs, flyers, and outlets. Get on our mailing list today.

## SENSATIONAL SPEAKER

**FAMOUS RCA 12" SPEAKER \$4.45**  
Will easily take up to 15 watts! Top quality reproduction of bass and treble frequency range. Uses strong 6.3 cc. Alnico V Magnet and has a voice coil impedance of 3.2 ohms. Excellent for replacement or new installations. Precision engineering and parts. 6 lbs. No. 991702R

**unbeatable... VALUE \$2.95**  
4 Tube Amplifier

**4 TUBE AMPLIFIER \$2.95**  
Push-pull output circuit designed for use with crystal pickup. Uses two 35A5 tubes, 14B6, and 25Y4 rectifier. 4-tube amplifier wired on right angle metal chassis includes volume control, pilot light, shielded lead and power line cord and plug. No. 991608R—Less Tubes, Shpg. wt. 1 lbs. \$2.95

**TUBULAR CONDENSER BUY! \$1.97**  
25 top quality tubular condensers at a real bargain price. Wax impregnated, non-inductivity wound. From .02 mfd. to .5 mfd. Long flexible pigtail leads. Individually tested to meet RMA standards. No. 993278R—Shpg. Wt. 1 1/2 lbs. \$1.97

## RADIO INTERCOM SYSTEM 2 WAY

**HOME NURSERY OFFICE GARAGE STORE \$12.95**

All you need to install it is a screw driver. Here's a complete 2-way system you can set up anywhere at all for direct inter-communication. Calls can originate from either end. A baby's whimper will pick up at 15 feet. So powerful, remote will operate over 2,000 ft. from master station. Plastic cabinets, tubes, 50 ft. connecting wire, etc. included.

No. 99N9582R—wt. 8 lbs. \$12.95

## ALL-STEEL MULTI DRAWER

**BUILDS INTO FILE CABINETS \$3.60**  
Convenient storage for small parts. Each unit constructed with tongue and slot designed to interlock with other units at top, bottom or side. Units may be fitted and securely locked around existing fixtures for economy of space. Each drawer has handy pull and holder for contents card. No. 18N2291R—Wt. 10 oz.—10 for \$3.60

## AUTOMATIC RECORD CHANGER

**only \$9.95**  
Jam proof and child proof—tone arm can be moved at any time without jamming unit or changing adjustments. Plays records manually or automatically. Plays ten 12" or twelve 10" records at one setting. Single control for simple operation. Lightweight crystal tone arm assures hi-fidelity. Constant-speed 110 V., 60 C., AC motor. Base—11 1/2" x 15 1/2". Requires 6" above and 2" below panel board. No. 99N9593R—12 lbs. Only... \$9.95

## Giant Book Just Off Press Bonanza for Servicemen! Lowest Prices in America FREE!! FREE!!

Think of what it means to sit down at your own leisure, in your own shop or home, and cover the entire radio and electronic field with this one catalog. There isn't a part made for radio that you won't find here—and at lower prices than any place in the world. 164 pages packed solid with electronic merchandise: every style, every type, every quality, all the big brand names and thousands of special-bargain items of top quality and rock-bottom prices.

Lafayette-Concord catalogs famous for 29 years. But this one is a real special. In the first place, Lafayette-Concord prices have been pared down to within a hairbreadth of our own cost. In the second place, our stocks on radio, television, phonographs and players of all types and speeds, recorders, loudspeakers, public address systems, ham gear, etc. are unmatched. Every single item described fully, with all the technical information you want. Yes, you can shop the entire radio world just with this one catalog—and know you're getting the lowest prices anywhere.

**SEND FOR YOUR COPY NOW**  
One penny—that's all it costs you to own this giant catalog. Just fill out the coupon below and paste it on a penny postcard. But do it quickly. These catalogs are going fast to oldtimers on our mailing lists and thousands of newcomers. Rush your request now!

**FLEXTRON WIRE STRIPPER Special!!! \$3.95**

A "must" for every TV serviceman's kit! Strips 300-ohm transmission line quickly, easily, cleanly. Merely insert twin lead in opening at top, turn bar handle a quarter turn, and pull out stripped wire ready for use. Made of durable metal. 8 oz. No. 18N15391R... \$3.95



**IT'S THE NEXT BEST THING TO A BIG BARGAIN BOOK!**

Free Consultation Service

One thing Lafayette has to offer you can't buy anywhere else at any price. It's our free consultation service. You see, Lafayette men are engineers, basically, and salesmen in the second place. No matter what your problem is in radio, electronics or television—you can write to us and ask for advice. You'll get honest suggestions and a patient, fully detailed answer. You don't have to feel obligated to buy merchandise just because you write for free advice. Our engineers eat, sleep and drink radio and electronics—and there's nothing in the world they'd rather think about. So write anytime or drop into any of our stores if you're in the vicinity. We'll answer your questions with the same speed that we fill mail orders—and, believe us, that's fast!

## ATTENTION EXPORTERS

Orders from friends outside the continental U. S. will get special attention and faster handling if they are addressed to the Export Division, New York

## SENSATIONAL VALUE!

**5 TUBE Superhet Kit \$11.95**  
This extremely popular A.C. DC kit comes with a handsome two-tone plastic cabinet. Circuit is 5-tube superheterodyne using 12SA7, 12SK7, 6X6, 12XQ7 and 50L6 tubes. Includes automatic volume control, true tone reproduction. Dial is streamlined with wide fan 2 ranges covering 50 to 1000 kilocycles. R.F. in top antenna. Minicock speaker. New low price includes cabinet and tubes. No. 992454R—shpg. wt. 3 lbs. \$11.95

# LAFAYETTE

the world's largest radio supply organization

## RUSH FOR FREE CATALOG!!!

**SHOP IN PERSON AT ANY ONE OF OUR OUTLETS:**

**NEW YORK**  
100 Sixth Avenue  
542 E. Fordham Rd., Bronx

**CHICAGO**  
901 W. Jackson Blvd., 229 W. Madison St.

**ATLANTA**  
265 Peachtree St.

**BOSTON**  
110 Federal St.

**NEWARK**  
24 Central Ave.

**LAFAYETTE RADIO Dept. J1-9**  
901 W. Jackson Blvd., Chicago 7  
100 Sixth Avenue, New York 13

**DON'T FORGET TO ORDER BARGAINS!**

Please send my FREE CATALOG No. 91.

Please fill attached order. I enclose \$ \_\_\_\_\_ in postal note, money order or check. Will remit few cents postage when order is received.

NAME \_\_\_\_\_

ADDRESS \_\_\_\_\_

CITY \_\_\_\_\_ ZONE \_\_\_\_\_ STATE \_\_\_\_\_

# European Report

By Major Ralph W. Hallows

RADIO-ELECTRONICS LONDON CORRESPONDENT

**NEW TELEKITS**  
NOW **59<sup>50</sup>**

Jobbers: Write for Price Information

**NEW TELEKITS**  
10-B \$82.99  
7-B \$59.50



Sparkling new Telekit 10-B has 52-inch screen. Brand new compact lay-out has video tube mounted on chassis. Big illustrated easy-to-follow instruction book guides you step by step through easy assembly. No special knowledge of television is required. All you need is a soldering iron, pliers, and screw driver. 10-B Kit can be used with 12½, 15, 16-inch tubes. Telekit 10-B, \$52.99. Tube kit, including 10BP4 and all other tubes, \$55.80. 10-B Telekit cabinet, \$15.95 to \$24.50. Telekit Guarantee includes free factory service.

Write for catalog listing 10-B and 7-B Telekits. New 7-B Telekit for 7-inch tube, \$59.50. Tube kit, including 7JP4, \$39.58. 7-B cabinet, \$15.95 to \$24.50.



Note simple clean lay-out for easy assembly of new Telekit 10-B. Features 2 sound I. F. stages, a new pre-built, pre-aligned tuner that includes a stage of R. F. for distance reception. Easy-to-adjust horizontal lock circuits. Beautiful new model cabinets for 7-B and 10-B are heavily constructed of hard rubbed walnut.

**13 CHANNEL TUNER**  
\$19.95



**NEW 13 CHANNEL TUNER** is a small compact unit with stage of R.F. Tunes all TV and ZFM channels. Made to conform with Telekit or any other TV set having video I.F. of 25.75 Mc. Complete with tubes, pre-wired, pre-aligned; only three connections to make. See your jobber, or write to us for information. Your cost, \$19.95.

Write for catalog of Telekit antennas, boosters, television kits, tuners, television ports and tubes.

**TELEKIT**  
SANDERS ELECTRONICS CO.  
AVIATION BLDG., 3240 N.W. 27th AVE.  
MIAMI 42, FLORIDA



**A** GREAT deal of work has been done in Britain and much is still being done on wide-range phonograph records. At first thought one might wonder why all the fuss. The upper limit of hearing in people under 40 years of age is no more, on the average, than about 14,000 cycles; few people above that age can hear sounds with frequencies higher than 10,000 cycles and there are very many people whose upper audibility limit is approximately 5,000 cycles. Good commercial phonograph discs record frequencies up to 10,000 cycles. What, then, is the use of working out ways of recording and reproducing frequencies up to 20,000 cycles if nobody is going to hear them?

The answer is that, though fre-

quencies of 15,000-20,000 cycles can't themselves be heard as sounds, their presence or absence in a disc played with a pickup, an amplifier, and a loud-speaker of the highest grade does very materially affect the quality of music. Persons with a complete acoustic cutoff above 10,000 cycles readily detect the difference between 10,000- and 20,000-cycle recordings and very much prefer the latter. The reason why this should be so is an interesting one, and I wonder whether you can puzzle out what it is before reading further. There's a clue to be found in television technique, where a visual problem on similar lines arises.

Here's the answer: It is very seldom that a steady tone occurs in music: the greater part of any piece of music is made up of more or less complex series of transients. And that word *transient* provides the key. A transient is a pulse consisting of a square or nearly square waveform. To reproduce such a waveform perfectly would, in theory at any rate, require the inclusion of *all* frequencies up to infinity. In practice, the steep rise from zero level at the beginning of a transient and the steep fall to zero level at its end are produced in a manner that satisfies the ear if the frequency-range is made 20,000 cycles. People who can actually hear no steady tone of above half this frequency distinguish the wide-range record at once and like it better because it brings out the transients crisply and clearly and does not slur them. You see now why TV might have furnished a clue? Tele-

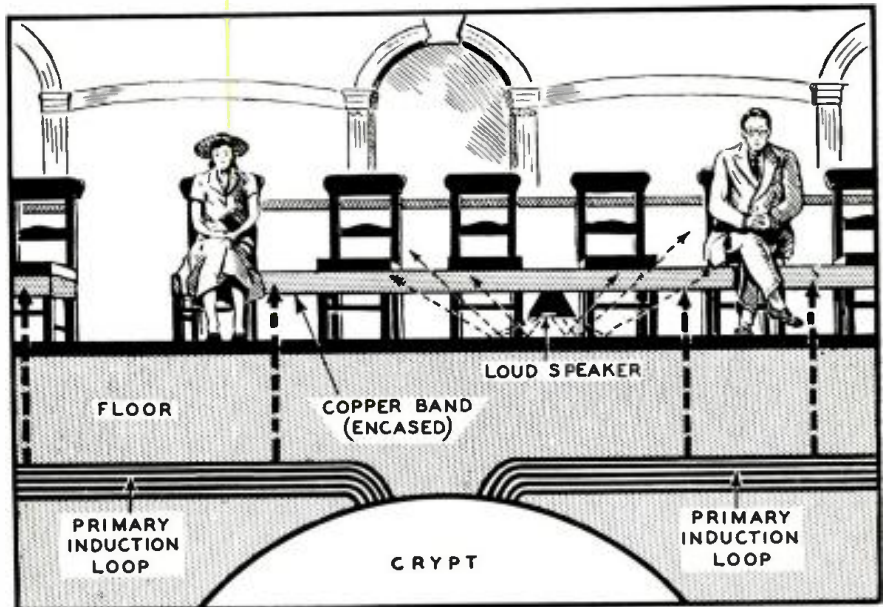

Fig. 1—Coupling between induction loops and copper bands transfers audio to drive speakers.

RADIO-ELECTRONICS for



vision is also largely a matter of transients, clear-cut changes from white to black or black to white, and a wide frequency band is again needed if fuzziness is to be avoided.

H.M.V and Columbia records are now being made with a 20,000-cycle frequency range. These recordings have a cross-over frequency of 250 cycles. Above that the recording curve is constant-velocity all the way to the final cutoff. Below the crossover the characteristic is constant-amplitude, falling by 6 db per octave. So far, no large number of wide-range records has been made.

The reproducing instrument is known as the "Electrogram." It contains no less than three loudspeakers. First comes a 13½ x 8-inch elliptical instrument, with aluminum center and a 10,000-gauss permanent magnet; next there is another aluminum-centered elliptical speaker, this time 10½ x 6½ inches, also with a 10,000-gauss permanent magnet; lastly, there is a flared-horn tweeter, using a metal ribbon of half a thousandth of an inch and having a 7,000-gauss permanent magnet.

**Loudspeakers in St. Paul's**

When Sir Christopher Wren built St. Paul's Cathedral in London nearly 250 years ago, he gave the world one of its most beautiful buildings. In his day, though, there was no such thing as a science of applied acoustics and, for all its beauty, St. Paul's has until now been one of the most exasperating of churches to both clergy and congregation. No preacher could make himself clearly heard by more than a few of his hearers; in some parts of the building both music and the spoken word were ruined by reverberations. So strong are these reverberations that they defeated all attempts to install systems of loudspeakers suspended from walls and pillars: the sounds became louder, but they also became more confused.

It was suggested some time ago that something might be done by fixing downward-pointing loudspeakers below the seats of selected rows. Sound waves would then be reflected upward and outward from the floor and the damping furnished by the seats themselves and by the clothes and bodies of their occupants should suffice to prevent reverberation effects. No way out of one big difficulty could, however, be found. The seats themselves are wooden chairs, fixed together in rows by battens. The seating has frequently to be rearranged for various ceremonies, and wire trailing about the stone floor just wouldn't do.

That problem has been solved by what comes virtually to turning the whole great building into one gigantic transformer. Down in the crypt is an audio amplifier with an output rating of 5 kilowatts. This feeds the primary of the transformer, or rather the primaries, for there are 14 of these, consisting of horizontal loops containing a total of four miles of wire, fixed to

# LOSE NO TIME

- 1 MAKE THE SALE!
- 2 MAKE THE INSTALLATION!
- 3 MAKE THE PROFIT!



With only 3 basic models in the HANDY TORQUE-DRIVE SALES and SERVICE KIT, you can immediately replace any one of over 150 standard type pickup cartridges in common use. There's no special trip to make to your supplier for a cartridge . . . there's no lost time, no lost sale! You make a quick profit . . . you make your customer happy . . . and you actually give him a superior cartridge! Ask your E-V Distributor or send for Bulletins 141-142. (New Model L14 Microgroove Crystal Cartridge also available)

E V Pat. Pend. Licensed under Brush Patents

**ELECTRO-VOICE, INC.**  
**BUCHANAN, MICHIGAN**

Export: 13 E. 40th St.,  
 New York 16, U.S.A.  
 Cables: Arlab

IT PAYS TO REPLACE WITH  
**Electro-Voice**



Exaggerated? Not by a jugful! So many claims are being made for the average capacitor these days, you'd almost need a test department like this to prove whether or not the manufacturers are telling the truth.

For everyday testing of essential capacitor characteristics in your own service shop, we recommend the Sprague Tel-Ohmike Analyzer. Measures capacitances from .00001 to 2000 mfd., electrolytic power factor to 50%, and electrolytic leakage under rated voltage from built-in power supply. Checks insulation resistance of ceramic, paper and mica capacitors. Measures resistors from 2.5 ohms to 25 megohms. Also is a 0-15-150-750 volt and 0-1.5-15-75 ma. volt-milliammeter.

Write for catalog M-414 today.

Sprague Tel-Ohmike analyzer for fast, easy testing of all essential capacitor and resistor characteristics.



Sprague Capacitors for dependable service in any application.

**SPRAGUE**

**SPRAGUE PRODUCTS CO., North Adams, Mass.**

Distributors' Division of the Sprague Electric Co.

Large prints of this Cartoon, suitable for framing, available. Send 10c to cover mailing and handling cost.

the roof of the crypt (Fig. 1). The 84 secondaries contain no wire at all! They are formed by copper bands, 4 inches wide and protected by wood casings, fitted around selected blocks of seats. Each secondary feeds a short-horn loudspeaker with an 8-ohm speech coil, the speaker pointing toward the floor. The fluctuating currents fed into the primary coils by the amplifier induce corresponding currents of adequate magnitude in the secondaries formed by the copper bands, and these feed the loudspeakers. The whole system is so designed that the maximum possible coupling is obtained between primaries and secondaries.

Between the primary coils and the secondary copper bands is the roof of the crypt and the floor of the cathedral itself. This is a mass of stone, rubble, brick and marble with an average thickness of 7 feet. There is also about a foot of air space between the floor and the copper bands. Hence the total separation of primary and secondary systems is approximately 8 feet—a fine practical demonstration of the efficiency of well-designed magnetic coupling.

The microphones are installed at the pulpit, the lectern, and the other key points. On the floor of the cathedral there is a control desk at which an operator sits throughout a service. He has before him a plan of the building, on which pilot lights indicate the microphones in circuit at any instant; he is thus able to ensure that every part of the service is properly handled by the "sound-reinforcement system," as it is called by its originators, the Pamphonic Co. The installation is working well and proving most satisfactory—no small achievement.

**A new "zoom" lens**

Those who watched on their TV screens the final match in this year's competition for the Football Association Cup saw a new and surprising feat. At exciting moments they had the impression that the camera was moved forward right on to the field, giving closeups of one small area, of a few players, and of the ball, around which activity was centered. The camera, of course, really stayed put in the commentator's box and didn't move an inch. The effect of movement right out among the players was produced by means of a new type of "zoom" lens. Fig. 2 shows diagrammatically the makeup of the lens. The portions A and

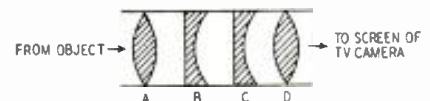

Fig. 2—Lens arrangement in the new "Zoomer."

D are fixed, but B and C can be moved by rotating the outer casing of the lens. When this is done, the focus of the final image on the TV camera screen remains unaltered, but the focal length of the combination can be changed. With lenses now in use the area covered by a portion of the image on the screen can be steadily increased until it is four times its original size.

RADIO-ELECTRONICS for



# McGEE'S WAREHOUSE CLEANUP SALE! AUTOMATIC RECORD CHANGERS \$9.95 up

## CAPEHART TWO POST \$9.95 RECORD CHANGER \$12.95

**Capehart Changer Scoop.** Used on famous, high priced combinations, but have been removed from sets; to be replaced with twin speed changers. May Require Minor adjustments. These have Capehart variable reluctance cartridges. Requires same gain as the G.E. Vii 114's. Weight 23 lbs. Stock No. N8-3, \$9.95. Extra tone arm, with MLP-1 Crystal cartridge and permanent needle, \$1.00 extra. Extra tone arm with G.E. HPX-010 variable reluctance cartridge, \$2.95 extra. Made to fit leatherette covered base, \$1.95 extra.

**Crescent Model 350** with Automatic, 70 cartridge. Plays 10, 12, 15 or 12 1/2 rpm records at 78 RPM. Base size 11 1/2 x 13". Net Price \$12.95. Two for \$25.00. A red top changer value. Weight 14 lbs. Made to fit leatherette covered base, \$1.95 extra.

## \$19.95 12 INCH COAXIAL P. M. SPEAKER RESPONSE \$12.95 40-17000 CPS

**General Instrument Stock No. G1-73.** Dual Speed, with Atlantic reversible cartridge; permanent needles. Plays 10, 12 1/2 or 15 rpm records, at 33 1/3 or 78 RPM. Net Price \$19.95. ea. \$17.95 if you buy with an S-56 or S-59.

Regular \$32.50 list nationally known, famous 12" Alnico V coaxial PM speaker. Matches any 8 ohm voice coil, only two wires to connect. This speaker used on nationally famous \$100.00 radio sets. Stock No. CR-13X, Weight 8 lbs. Net \$12.95. two for \$24.95.



## HALLICRAFTER'S S-56 \$59.95 \$110.00 VALUE 11-TUBE FM-AM CHASSIS \*AUTOMATIC FREQUENCY CONTROL ON F.M.

**Model S-56 Hallcrafters,** high fidelity, 11 tube AM/FM radio receiver chassis for the broadcast band and FM 88 to 104 mcgacycles. Automatic frequency control on FM holds the station on 12.7 mc zero connection on rear of chassis. Full range tone control with base boost, push pull 6B6 tubes, in audio system. Frequency response essentially flat from 60 to 14000 cps. Wide vision accurately calibrated slide rule dial, with pre-selection on broadcast band. Output transformer matches 500 ohm line, 1 Antenna terminal; two for AM and two for FM. This is the home radio control we know of today. Better get your order in early. Designed to be used in commercial radios selling in the \$40.00 to \$60.00 class. The regular dealers net on this chassis is \$100.00. However, a lucky few are offering this chassis for \$59.95. S-56 Hallcrafters chassis complete with tubes and operation instructions, at only \$59.95. 12 1/2 x 10 x 7 3/4". Weight 25 lbs. Buy your S-56 with a wide range PM speaker. Pick your combination from the prices listed below and save.

### 11-TUBE FM/AM MODEL S-56, \$59.95

radios selling in the \$40.00 to \$60.00 class. The regular dealers net on this chassis is \$100.00. However, a lucky few are offering this chassis for \$59.95. S-56 Hallcrafters chassis complete with tubes and operation instructions, at only \$59.95. 12 1/2 x 10 x 7 3/4". Weight 25 lbs. Buy your S-56 with a wide range PM speaker. Pick your combination from the prices listed below and save.

**Hallcrafters S-56 Chassis with Tubes,** 500 ohm to speaker matching transformer and our Model CR-13X 12 inch coaxial PM wide range speaker. This gives you a complete radio for custom installations. Shipping weight 37 lbs. Stock No. S-56 A, 15 PM Jensen Speaker, S-56 chassis and speaker matching trans, all for \$71.95. G.I. Dual speed changer, Stock No. G1-73 \$17.95.

**Hallcrafters S-56 Chassis with Tubes,** 500 ohm to speaker matching transformer and our Model CR-13X 12 inch coaxial PM wide range speaker. This gives you a complete radio for custom installations. Shipping weight 37 lbs. Stock No. S-56 A, 15 PM Jensen Speaker, S-56 chassis and speaker matching trans, all for \$71.95. G.I. Dual speed changer, Stock No. G1-73 \$17.95.

## HALLICRAFTER'S S-59 \$32.95 8-TUBE FM-AM CHASSIS PUSH-PULL AUDIO—AC CONSTRUCTION

**Model S-59 Hallcrafters,** high fidelity, 8 tube custom receiver chassis, for FM/AM reception. Size 12 1/2 x 7 1/2 x 9". An excellently engineered chassis, equal to \$40.00 commercial sets. Wide range audio, 60 to 14000 cps., tone control, phono input jack on chassis. Receives broadcast, 540 to 1700 kc. auto-tune, 100 to 1000 mc. Accurate side rate dial. Any good PM speaker or console cabinet at left \$29.95 extra. S-59 custom chassis and tubes, with our regular \$12.95, CR-13X Coaxial 12" PM speaker, all for \$42.95.

### 8-TUBE FM/AM MODEL S-59, \$32.95

Stock No. JH-5X same as above but with 1500 ohm to speaker matching transformer. Shipping weight 20 lbs. Net \$32.95.

## CONSOLE CABINET FOR S-59 \$19.95

Beautiful blond console cabinet. Size 17 x 21 x 33" high. This cabinet was intended for use on a nationally known \$120.00 radio-phonograph combination. The lower half of the cabinet is divided for albums. The upper half has a hinged lid, which covers the radio and changer. Radio panel is covered with a hinged lid. This cabinet is designed to be used with a blank panel for installing your own chassis. Changer panel is blank, will hold a changer up to 12 x 15" cabinet net hold a 6" or 8" x 6" x 4" speaker. Shipping weight 40 lbs. Stock No. JB-10, blond cabinet ready cut for the S-59 Hallcrafters will not hold S-50! \$19.95 6 x 9" \$4.00—Alnico V PM speaker, \$2.95 extra. \$19.95 8 x 10" \$4.00—Alnico V PM speaker, \$2.95 extra. \$19.95 Stock No. B-1000 cabinet just as we bought them. You redo the radio and changer area to suit your own need. Changer area is now 15 x 15" and radio area 5 x 15 x 11 1/2" Stock No. B-1000. Shipping weight 40 lbs. \$14.95

## OUTPUT TRANSFORMER HIGH FIDELITY 20-20,000 C.P.S. SCOOP PRICE \$6.95 EACH

Why pay \$20.00 or \$30.00 for an output transformer, when you can get a high fidelity output transformer, designed to match push-pull plates, 2-6V6, 2-6AV5, 2-6AV5 class A1, to 4-8-15-250 and 500 ohm; with a 100% feedback winding. Housed in a rugged metal case. If you want the best quality from your audio system, order this transformer. Response essentially flat from 20 to 20,000 cycles. We have tried several high fidelity outputs in our lab, and this is the best value. Even though your amplifier only puts out 10 or 15 watts, this 31 watt job is what you should have. Complete instructions are furnished. Stock No. A-404, shipping weight 8 lbs. Net price \$6.95.



## 12-TUBE FM-AM KIT \$39.95

**12 Tube Kit Model PRK-51.** This is the most elaborate radio, P.A. kit that our engineering department could design. Here are its features: Receives broadcast, 530 to 1700 kc and FM 88 to 104 mc 13 gang tuning on FM. The audio system is wide range, 40 to 17,000 cps. 5 lb. interwound high fidelity output matches 8 ohm speaker. Four tone controls, base and treble boost. Phonograph inputs for standard or General Electric variable reluctance Mike and crystal or dynamic mike. This radio may be used for an 18-watt P.A. system, a recording amplifier, or with a high fidelity 50 V.T. audio system. Chassis size, 15 1/2 x 7 1/2 x 7 1/2" including tubes. GA65, 6SN7, 2-61A6, 6AT6, 6HG, 6BE6, 2-2A7T, 2-6V6 and 5Y3. The FM RF section is ready wired coils and sockets, to make this kit easier for you to build. 0" slide rule dial. Complete kit Model PRK-51, with photos and instructions, \$39.95. Weight, 28 lbs. Speaker recommended, Oxford 12", 22 oz. 12-XMS, \$10.00 extra.

## ST. GEORGE WIRE RECORDER MECH. \$22.95

**St. George Wire Recorder Mechanism.** Brand new, complete, including recording and playback mechanism. Also plays 78 RPM records when crystal pickup is installed. Records and plays back up to 10000 cycles per second. Standard Webster wire. Furnished with diagram for 3 tone converter (adapts radio or amplifier for recording). Shipping weight 15 lbs. Requires 9 x 13 x 3 1/2" space. Net \$22.95. Crystal pickup for playing, \$1.00 extra. 1500 cycle tone arm, \$1.95 extra. 15' timer wire, 1 hour, \$3.25. 30 min., \$9.95. 15' timer wire, \$1.30. Crystal mike and desk stand \$4.95 extra.

## 6 TUBE AC DC KIT \$9.95

**6 Tube Superhet, Broadcast AC-DC Kit.** using full size tubes. Housed in a sturdy plastic cabinet, with slide rule dial. RF stage, 2 gang condenser, loop antenna and 10" speaker. This makes a factory like radio. The condium chassis is ready punched and sockets are installed. This type of kit usually sells for a least \$12.00. All kit components are ready punched chassis. One kit Model PRK-51, with photos and instructions, including tubes: 12K8, 2-12SK7, 2-12AT7, 2-6V6, 5Y3. Complete kit Model PRK-51, with photos and instructions, \$9.95.

## GI. 13 CHANNEL TV FRONT END \$7.95

**13 Channel Television Front End.** Permanently tuned, with 13 position switch. Built in oscillator trimmer. Price complete with tubes: 6C4 and 2-6AG5. This TV front end may be used with our Farnsworth, GVZ-60 chassis. Output feeds to video changer. Stock No. MAH-13 T.V. front end with tubes, \$7.95. We have a few of these tuners, that have the fine tuning eye, trimmer missing. Otherwise, used return and may have broke. Write form, No. MA-13AT. \$1.95. **Sarkis-Farzan, 13 channel tuner** for Television receiver. This tuner is built in all wire, including tube sockets. The same TV manufacturer. Built in antenna trimmer. Offered with printed schematic diagram. Priced complete with 3 tubes; 6C4 used, 6AG5 tuner and 6X4 RF amplifier. This unit is worth twice our price. All wired. It can be mounted and used with the Farnsworth GVZ-60 chassis, advertised to the left. Weight 2 lbs. Stock No. SK-73. Net price, \$7.95. 13 channel tuner, \$3 tubes, \$7.95.

## TELEVISION POWER TRANS. \$2.95

**GVZ-60 Power Transformer.** C-03240Z. A 137 ma. tapped 110 volt primary, supplies plate voltage and filament for part of Farnsworth T.V. chassis. 6.3 volts 3 C, 6.3 and 5 volt filament. Adjustable voltage. Size 3 1/2 x 3 1/2 x 5 1/2". Shipping weight, 1 lb. Stock No. GVZ-60 Power Transformer, \$2.95.

## JEFFERSON T.V. PWR. TRAN \$2.49

**T.V. Power Transformer,** similar to R.C.A. 200 filament, 110 volts, 6C cycle, 700 volts R.C. filament, 3 volts at 3 arms, 5 volts at 4 arms and 6.3 volt at 8 arms. Trans. size 3 1/2 x 4 1/2 x 5 1/2". Shipping weight, 12 lbs. Stock No. MH-48. Net price, \$2.49.

## WIRE RECORDER CONVERTER \$12.35

With this 3-tube converter you can adapt the St. George Arko or Webster Chicago wire recorder mechanism to any radio or P.A. system. Only 3 connections necessary. Just plug it into the phono input of your amplifier and connect to the radio or P.A. tube. AC transformer construction, gain for mike, 3 tone converter for quick changing from record to play-back. Priced ready wired and tested with instructions and tube 12AT7, neon indicator, 6X2 G.I. oscillator tube; 6X3 rectifier. Stock No. BR-4, net, \$12.95.

## 12 WATT KIT 20 WATT KIT \$10.95 \$15.95

**Kit Model TM-12, 12 Watt Amplifier Kit.** Ideal for a high quality record player as a P.A. system or recording amplifier. Matched component parts. Compensation for G.E. control fades from phono to mike. Input compensation for G.E. Variable Reluctance pick up. Push pull 100 Mill Power Transformer, complete with tubes, diagram and photos, 2-6V6, 2-12AX7, 2-12AT7, 2-6X4, 5Y3. Complete kit Model TM-12, weight 10 lbs. Net \$10.95. Crystal pickup mike and desk stand \$4.95 extra. TM-12 custom wired and tested \$5.00 extra.

## 20 WATT KIT \$15.95

**Kit Model TM-20, A high quality 20 watt Audio Amplifier with 135 Mill Power Transformer and push pull 61A's. Inputs for mike and record. Compensation for G.E. Variable Reluctance pick up. Tone and fader controls. Has heavy duty universal output transformer. Ready punched chassis. Price includes tubes, diagram and photos, 2-6V6, 2-7N7, 724. Complete kit Model TM-20, weight 10 lbs. Net \$15.95. TM-20 custom wired and tested \$5.00 extra.**

## KIT MODEL X-45 KIT MODEL DE-6X \$12.95 \$5.95

**Complete Personal Portable Radio Kit Model X-45.** Made from genuine Gano factory. Matched parts. A complete kit to build a broadcast battery operated 4 tube receiver. 100 Mill Power Transformer, complete with tubes, diagram and photos, 2-6V6, 2-12AX7, 2-12AT7, 2-6X4, 5Y3. Complete kit Model X-45, weight 10 lbs. Net \$12.95. TM-12 custom wired and tested \$5.00 extra.

## TELEVISION COURSE \$3.00

**Sam's Television Course book,** 216 pages. T.V. explained to you in everyday language. We think it's the finest value today. Net \$3.00. **Ward TV-9 Television antenna,** \$3.00. High and low band folded dipole, with reflectors and mast. Regular \$15.00 net. McGee's sale price, \$3.00. \$6.45

## 5 WATT KIT 8 WATT KIT \$6.95 \$8.95

**Kit Model TM-4, 5 Watt Amplifier Kit.** Ideal for recording mechanism. Has features of higher priced amplifiers. Inputs for phono pick up or mike. Compensation for the G.E. Variable Reluctance pick up. Push pull output gives good tone quality. Output to 8 ohm Voice Coil. Variable tone control and fader control. Ready punched chassis. This makes a top quality AC-DC Audio Amplifier. Priced complete with tubes, diagram and photos, 2-50B5, 2-12AX7, 2-6V6, 2-6X4, 5Y3. Complete kit Model TM-4, \$6.95. Crystal mike and desk stand \$4.95 extra. TM-4 custom wired and tested \$3.00 extra.

## 12 WATT KIT 20 WATT KIT \$10.95 \$15.95

**Kit Model TM-12, 12 Watt Amplifier Kit.** Ideal for a high quality record player as a P.A. system or recording amplifier. Matched component parts. Compensation for G.E. control fades from phono to mike. Input compensation for G.E. Variable Reluctance pick up. Push pull 100 Mill Power Transformer, complete with tubes, diagram and photos, 2-6V6, 2-12AX7, 2-12AT7, 2-6X4, 5Y3. Complete kit Model TM-12, weight 10 lbs. Net \$10.95. Crystal pickup mike and desk stand \$4.95 extra. TM-12 custom wired and tested \$5.00 extra.

## 20 WATT KIT \$15.95

**Kit Model TM-20, A high quality 20 watt Audio Amplifier with 135 Mill Power Transformer and push pull 61A's. Inputs for mike and record. Compensation for G.E. Variable Reluctance pick up. Tone and fader controls. Has heavy duty universal output transformer. Ready punched chassis. Price includes tubes, diagram and photos, 2-6V6, 2-7N7, 724. Complete kit Model TM-20, weight 10 lbs. Net \$15.95. TM-20 custom wired and tested \$5.00 extra.**

## KIT MODEL X-45 KIT MODEL DE-6X \$12.95 \$5.95

**Complete Mike Broadcaster Kit Model DE-6X.** Broadcasts 800 to 1300 kc from either a phonograph pick up or mike. Makes any radio receiver a P.A. system or recording amplifier. Broadcasts with ease. Has fader control from mike to record simulating a regular broadcast station. Works on 110 Volt AC. Ready punched chassis. Price includes a wiring diagram, photos and tubes, 2-35B5, 12X7, 35W4. Kit Model DE-6X, Weight 4 lbs. Net \$12.95. Crystal Mike and desk stand \$4.95 extra.

## 3-WAY—PICK ME UP PORTABLE RADIO ONLY \$12.95

**Sensational New 3-Way Portable Radio Kit,** 4 tubes plus rectifier. Housed in an all aluminum, leatherette covered case made in the U.S.A. with top up lid with pop antenna built-in. Size 9 x 9 x 6". Build yourself a professional looking radio with this kit. Every piece furnished including tubes, 12K8, 12A7, 12B5, and 3V4. As easy to follow diagram and photo. Receives broadcast 540 to 1700 kc. Tone control makes this two gang superhet, that looks like a \$30.00 radio. We should ask \$17.00 for this kit. However, McGee's Warehouse makes this \$12.95 price possible. Stock No. FR-4X, complete kit less battery, shipping weight 9 lbs. Net price \$12.95. Kit of batteries, 67 1/2 volt "B" and "A", \$2.25 extra.

# McGEE RADIO COMPANY

Prices F.O.B. K.C. Send 25% deposit with order. Bal. net C.O.D. With Parcel Post Orders include Postage. **WRITE FOR BARGAIN FLYER.** 1424 Grand Ave., Kansas City, Missouri



# TRANSVISION TELEVISION KITS AND INSTRUMENTS

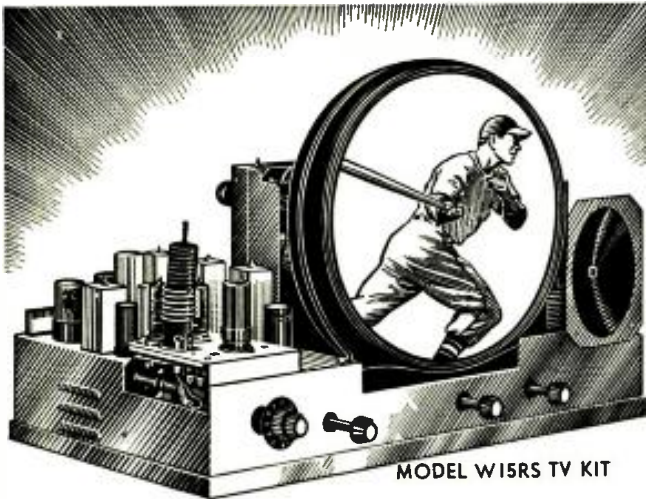

Build it in 1 Day!

GIANT 160 Sq. In. PICTURE Has 16" PICTURE TUBE

MODEL W15RS TV KIT

- (All-Glass Picture Tube, giving bright, clear, steady picture.)
- KIT COMES SEMI-WIRED and ALIGNED. Can be completed in one day!
- SAVE by installing the set yourself.

NEW LOW PRICES! SAVE UP TO 1/2 on the cost of equivalent picture-size sets. For NEW LOW PRICES, see your Transvision Outlet listed below.

## Eliminate the Variables in Television Installation with the Transvision FIELD STRENGTH METER Improves Installations! ! Saves 1/2 the Work! !

Has numerous features and advantages, including—(1) Measures actual picture signal strength . . . (2) Permits actual picture signal measurements without the use of a complete television set.



- (3) Antenna orientation can be done exactly . . . (4) Measures losses or gain of various antenna and lead-in combinations . . . (5) Useful for checking receiver re-radiation (local oscillator) . . . (6) 12 CHANNEL SELECTOR . . . (7) Amplitudes of interfering signals can be checked . . . (8) Weighs only 5 lbs. . . . (9) Individually calibrated . . . (10) Housed in attractive metal carrying case . . . (11) Initial cost of this unit is covered after only 3 or 4 installations . . . (12) Operates on 110V, 60 Cycles, AC.

NEW LOW PRICE Model FSM-1, complete with tubes Net \$79.50

## TRANSVISION ALL-CHANNEL TELEVISION BOOSTER CONTINUOUS TUNING



Model B-1 . . . . . List \$32.50

All Transvision Prices are fair traded; subject to change without notice. Prices 5% higher west of the Mississippi.

## SERVICE-DEALERS . . . Be the TV Parts Jobber and Service Center in your community!

- Beat competition at a profit.
- Stop being undersold—by anybody!

Here's a real opportunity to MAKE MONEY in Television. If you can qualify, you can become the Transvision Television Center in your community—and BUY TV and RADIO PARTS AT JOBBER PRICES. Practically no investment required. This offer is open only to service-dealers in territories where we do not have an authorized distributor.

Contact Transvision Outlets listed below, or write to New Rochelle, for details on Transvision's "TV Center Plan." DO IT TODAY!

TRANSVISION, INC., Dept. RE, NEW ROCHELLE, N.Y.

For FREE 20-page TV BOOKLET and CATALOG SHEETS, SEE YOUR TRANSVISION OUTLET!

- CALIF: 8572 Santa Monica Blvd., Hollywood 3471 California St., San Francisco. 4 East 15th St., Wilmington
- ILL: 1002 So. Michigan Ave., Chicago
- MD: 1912 No. Charles St., Baltimore
- MASS: 1306 Boylston St., Boston
- N. J.: 601 Broad St., Newark
- N. Y.: 1425 Boscobel Ave., The Bronx 485 Coney Island Ave., Brooklyn 167-01 Hillside Ave., Jamaica

- 75 Church St., New York City
- 606 Central Park Ave., Yonkers
- 622 No. Salina St., Syracuse
- Fourth & Plum Sts., Cincinnati
- 2001 Euclid Ave., Cleveland
- 53 W. Norwich Ave., Columbus
- OHIO:
- PENNA: 235 No. Broad St., Philadelphia 620 Grant St., Pittsburgh
- TEXAS: 700 Commerce St., Dallas
- CANADA: Hamilton, Ont.

## QUARTZ CRYSTAL TEST UNIT

Quartz crystals—particularly those cut for the higher frequencies—become sluggish in performance and even un-serviceable when allowed to remain unused for long periods of time. A simple test circuit, described in *Electronic Engineering* (England), can be used for periodically exciting unused crystals and for making qualitative measurements on them.

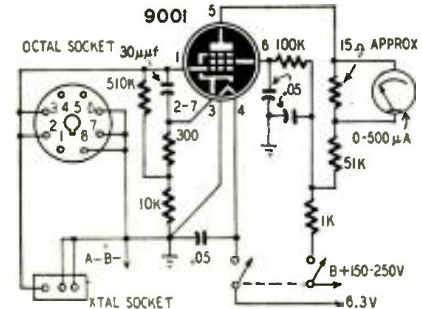

There being no circuits to tune, the device checks crystals regardless of frequency. A three-prong crystal socket and an octal tube socket are wired to take most of the available crystal holders. Operating voltages may be taken from any convenient source.

The circuit is a cathode-feedback oscillator with a 500-µa meter in its plate circuit. The supply voltage and the meter shunt are varied until the meter reads approximately 450 µa. Plug in a crystal. If it is good, the current will drop to about 250 µa, depending on the activity of the crystal. A bad crystal will cause the meter first to kick and then to return to the original standing current.

Crystals will not go sour if given a short workout in this device once every four months or so.

## 6-METER TRANSMITTER

Australian amateurs are very active on 6 meters. Some VK's have made WAS on this band, and others are well on their way to making WAC. The diagram shows a simple 20-watt, 6-meter phone transmitter similar to the ones used by many VK's. It was described in *The Australian Shortwave Handbook*.

The oscillator is a 6V6-G tri-tet using an 8.3-mc crystal and tripling in the plate circuit. This is followed by a 6V6-G doubler which drives the 807 50-mc amplifier. The modulator is a 6N7 driven by a cascade-connected 6SN7-GT working from a carbon microphone. Crystal or dynamic microphones can be used if a high-gain amplifier is added ahead of the 6SN7-GT. The 6V6-G's are operated with low screen voltage so the 807 will not be overdriven. Grid current for the 807 is about 2 ma for the specified plate voltage.

The oscillator and final amplifier plate coils and tuning capacitors are above the chassis, and all others are below it. The 807 is mounted horizontally so its grid connection is directly above the doubler plate coil.

RADIO-ELECTRONICS for





**THE ONLY**  
**Professional Tape Recorder**  
**In the Popular-Price Field!**

**TWIN-TRAX  
 RECORDER**

Before you buy any tape recorder, we invite you to send for our literature and study the specifications and performance ratings of the Twin-Trax Recorder. You will find it hard to believe that so much value can be sold at so low a price. But you will learn why "Twin-Trax" has become the "buy-word" among broadcast stations, recording studios, schools, and all critical music lovers who have finally found in Twin-Trax the perfect recorder at the price they can afford to pay.

The 10-tube amplifier—with individual bass and treble equalization, separate record and playback amplifiers, distortion-free super-sonic bias oscillator and erase amplifier—represents the finest electronic circuits ever designed for magnetic recording. The ultra-modern precision-built chassis is a genuine, exclusive "Twin-Trax" mechanism, product of the originator and leader in two-channel recording—not to be confused with inferior "look-alike" chassis offered by imitators.

Our free literature tells the complete story, furnishing technical information no other tape recorder manufacturer dares to offer. Write today.

**RACK-MOUNT**  
**PORTABLE**  
**4-HOUR PLAY**  
**TABLE MODEL**

**TWIN-TRAX DIVISION** \*Registered trade mark  
**AMPLIFIER CORP. OF AMERICA**

398-10 Broadway

New York 13, N. Y.

## Discover URANIUM!!!

Win HUGE U.S. GOV'T. CASH AWARDS!

Locate Radioactive Ores with  
**The "SNIFFER"**  
 a Revolutionary Geiger-Müller  
 counter

**\$54.50**

**COMPLETE!**



A precision Uranium Detector made by a leading manufacturer of high calibre radiation detection and measuring equipment for the United States Government and its national atomic laboratories.

Weighs about 2 lbs. . . . Extremely sensitive, yet rugged . . . Very loud signals . . . operates on easily available & replaceable flashlight batteries . . . anyone can operate it . . . widely used by geologists, large mining companies and amateur prospectors.

MAIL ORDERS PROMPTLY FILLED FROM STOCK



**The RADIAC Co.**

489 Fifth Avenue New York City, N. Y.  
 (Tel. Mu 7-7833)

## CONTINUOUS TAPE

Amplifier Corp. of America  
 New York, N. Y.

Continual repetition of any recorded message, from a 4-second minimum duration to a maximum of 10 minutes, is possible through the use of continuous loop-drive mechanism available as optional equipment on any standard Twin-Trax tape recorder.

Two variations of the continuous loop drive are available. Model CL-3 will record and play back messages anywhere from 4 seconds to 3 minutes in duration. During operation, a sufficiently long strip of standard 1/4-inch sound-recording tape is spooled on a stationary hub. The inside layer of the tape is fed through a slot in the hub, past an idler, past the record-playback head, and engaged by the pulling capstan. The beginning of the tape is then joined to the end to form a continuous loop which will continue to repeat the recording until the machine is shut off.



Model CL-10, which will accommodate messages from 4 seconds to 10 minutes, operates on the same principle, but utilizes a storage system with lower inherent friction, accomplished through the use of ball-bearing rollers.

Either model can be adapted for automatic recycling, a system which sets the Twin-Trax recorder in RECORD position when the press-to-talk switch of the microphone is operated. Release of the switch resets the instrument into PLAY position.

Installation of either model, with or without recycling will not interfere with the normal manual operation of the instrument.

## SINGLE HEADSET

Telex, Inc.  
 Minneapolis, Minn.

Designed for the greatest possible wearing comfort, the Earset is a single hearing-aid-type, headphone mounted in a flat plastic frame. The frame fits



over the ear, and the phone can be adjusted in a slot to the best position for the wearer's ear. It may also be removed and the frame reversed so that the set may be worn on either ear. Available in either high- or low-impedance models the Earset requires 0.3-aw input for comfortable listening.

## WIDEBAND AMPLIFIER

Spencer-Kennedy Laboratories  
 Cambridge, Mass.

The model 202 Wide-Band Chain Amplifier, composed of two stages of 6AK5 tubes, has a gain of 20 db and a bandwidth of 200 mc. With a standing-wave ratio of less than 1.5, db transmission characteristic is  $\pm 1.5$  db

from 100 kilocycles to 200 megacycles at an impedance level of 200 ohms.

The model 202 amplifier uses a traveling-wave circuit to achieve its bandwidth. It is well adapted for use with signal, sweep and pulse generators, vacuum-tube voltmeters, and television testing equipment.

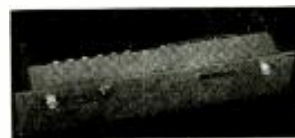

Mutual inductance coupling between sections of the r.f. lines in the grid and plate circuits of the tubes insures a substantial near phase shift over the bandwidth. Combining flexibility, light weight and rack or table mounting, the model 202 Wide-Band Chain Amplifier is a valuable instrument in general laboratory measurements, or cilligraphy and clear instrumentation.

## PERSONAL RADIO

Air King Products Co., Inc.  
 Brooklyn, N. Y.

The Pockette—model A425, is a 4-tube superheterodyne broadcast-band receiver (complete with loudspeaker) measuring 5 1/4 x 3 1/4 x 3 1/2 inches in its black plastic case. It uses a 1.5-volt filament cell and a 45-volt 8-battery. It weighs just over 2 1/4 pounds in operating condition. The tubes are 155, 1R5, 1T4 and 354.

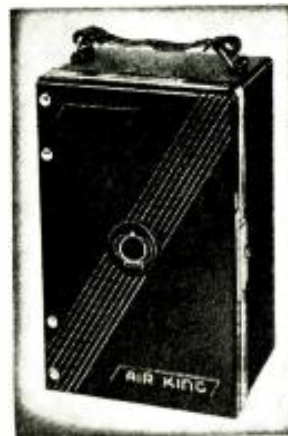

The sample inspected showed solid internal construction, with parts so placed that servicing should not be a burdensome chore.

## ANTENNA ROTATOR

Radiart Corp.  
 Cleveland, Ohio

The Tele-Rotor is intended for orienting television receiving antennas for the best reception on each channel; but since it will take a 150-lb load and mounts up to 12 inches in diameter, it is undoubtedly suitable for other services as well. It will rotate 375 degrees in either direction at a speed of 1 r.p.m. The control box contains a toggle switch and four lights labeled N, E, S, and W to indicate the direction in which the beam is pointed. Power consumption is about 20 watts.

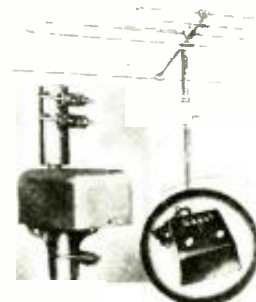

RADIO-ELECTRONICS for



## DIELECTRIC MATERIAL

Henry L. Crowley & Co., Inc.,  
West Orange, N. J.

A new dielectric material, Crothane, provides better characteristics at a cost comparable to that of ordinary materials. Supplied in flat plates or in tubes, the diameters of which can be held to within  $\pm .001$  inch, it can be pressed and extruded to shape, as well as machined with high speed tools. It is especially suited as a substitute for paraffin and Bakelite in impregnated paper tubes. Depending on the grade used, the power factor ranges from 2.8% to 3%; the dielectric constant is between 2.6 and 3.8.

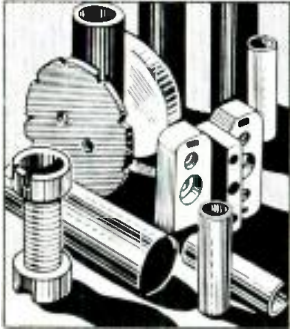

## TELEVISION TUNER

Standard Coil Products Co., Inc.,  
Chicago, Ill.

The Standard Tuner is part of a new standard-brand television receivers now available as a replacement item because of expanded production facilities. It has heretofore been supplied exclusively to manufacturers. The tuner

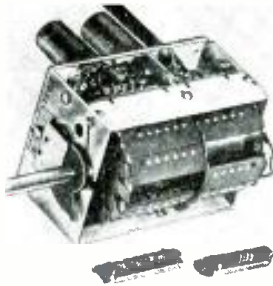

covers all 12 channels with plug-in inductors; an oscillator adjustment screw being provided for each channel. This tuner is suitable for conversion to a master as outlined in the article by Matt Mandl in the August issue of RADIO-ELECTRONICS.

## V.H.F. MILLIVOLTMETER

Millivac Instruments  
New Haven, Conn.

The new Millivac MV 18A vacuum tube voltmeter measures r. f. voltages down to a single millivolt at frequencies between 1 and 100 mc. In this frequency range it is flat within 10%. When used for higher frequencies, corrections have to be made. The instrument can be used for frequencies as high as 2,500 mc. 10 m.p.s. being the lowest voltage which can be read.

For low voltage measurements the



MV 18A uses germanium "pseudo-thermopiles" as a detector, and a highly sensitive, high impedance, carrier free d.c. amplifier which converts into meter readings the minute d.c. voltages developed by the thermoelectric effect within the germanium crystal. For high voltage measurements (up to 1,000 volts) the crystal diode rectification is used. Three different germanium probes having various capacitive input dividers to "trade surplus sensitivity for minimum circuit loading" are available for this purpose.

Direct TV and FM field strength measurements, complete r. f. signal tracing through TV and FM receivers as actual operating signal levels and v.h.f. and u.h.f. laboratory research are among the most important applications of this instrument.

## HIGH-VOLTAGE TESTER

Industrial Devices, Inc.  
Edgewater, N. J.

The Hi Volt is a neon-type voltage indicator designed for measuring high potentials. Model 500 is made for checking the output of oil burner-ignition gas-discharge display signs, and similar transformers, while model 520 is specifically intended for television and oscilloscope work. The user places the test prod and the alligator clip across the circuit to be tested and turns the knob on the 7-inch probe handle until the neon lamp goes out. The knob then points to the correct voltage. Model 500 draws less than 1 ma from the circuit and model 520 passes less than 300  $\mu$ a.



## SELENIUM RECTIFIERS

International Rectifier Corp.,  
Los Angeles, Calif.

The selenium rectifier stack shown features a special moisture proof finish capable of withstanding salt spray, such as encountered in naval and aerospace installations, for periods up to 200 hours. This special protective finish, obtained by a triple dipped coating process, is especially recommended for service under adverse atmospheric conditions such as high humidity, in tropical climates (where fungicidal corrosion is likely), corrosive fumes (such as in hospital) etc.



The rectifier plates are made in six standard sizes ranging from 1/4 x 1/4 to 6 x 7 1/2 inches; the latter size being the largest selenium rectifier plate commercially available in the United States. D. c. power requirements from 2 volts and 150 ma to 5,000 volts and 10,000 amperes (and above) can be handled with efficiencies varying from 65% to 85%, depending upon the circuit employed. Each of the rectifier plates is rated at 26 volts r.m.s. in series voltage.

These selenium rectifiers are capable of withstanding 1,000% overload for intermittent service.

## TELEVISION SLIDES

Teck-Vison Pictures  
Los Angeles, Calif.

Teck-Vison offers a series of 35 mm slides on all phases of radio and television. Waveforms are shown starting from the first detector and continuing through the various sound and vision circuits. After the sync separator, both composite and horizontal are shown under actual conditions.

Reference slides show both correct and incorrect settings of each trap and i.f. amplifier. Other slides are available on front-end tuners, video response curves, and television chassis. Also available is a 16 mm silent moving picture on waveform analysis.

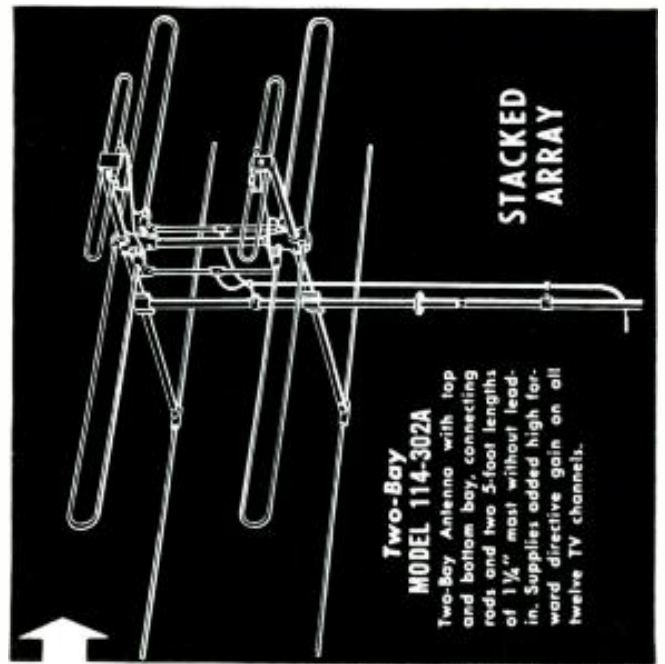

STACKED  
ARRAY

## Two-Bay MODEL 114-302A

Two-Bay Antenna with top and bottom bay, connecting rods and two 5-foot lengths of 1 1/2" mast without lead-in. Supplies added high forward directive gain on all twelve TV channels.

# TV ANTENNAS



The best reception of picture and sound on ALL TV CHANNELS is directly dependent upon the mechanical and electrical construction of the antenna.

Amphenol has designed the Model 114-005 INLINE TV ANTENNA after years of study and research to meet the strict demands for optimum antenna performance... this antenna provides the best in high, uniform gain with clear, brilliant reception on all channels. The Model 114-302A TWO-BAY INLINE TV ANTENNA provides added high forward gain for TV sets in fringe areas.

Costly service calls due to antenna maintenance problems are eliminated with an Amphenol installation. The faithful, steady performance of Amphenol antennas is the solution for excellent picture reception through many years.

Amphenol Inline Antennas are manufactured under Patent No. 2,474,480.

AMPHENOL PHENOLIC CORPORATION  
1830 SO. 54TH AVENUE  
CHICAGO 50, ILLINOIS



## Single Bay MODEL 114-005

Complete with mast, swivel mounting plate, guy clamp, stand-off insulators and 75 ft. Amphenol 300 ohm Twin-Lead.

## MODEL 114-009

Standard 114-005 TV antenna without Twin-Lead.

# \$ \$ SAVE!! \$ \$

## AT UNITED

### HAMS! SERVICEMEN! EXPERIMENTERS! RADIO PARTS KITS RESISTORS, ASSORTED VALUES

- No. 1 Carbon, Non insulated, 1/4 W. to 2W. 100 for 65c.  
No. 2 Carbon, Insulated 1/4 W. to 2W. 100 for \$1.69.  
No. 3 Wire wound, Enameled, 5W. to 50W. 25 for \$1.95.  
No. 4 Ohmite Carbon 1/2 and 1W. 125 ohms to 6 Meg. 100 for 98c.

### CONDENSERS, ASSORTED VOLTAGES

- No. 5 Paper tubular, .0003 Mfd. to .1 Mfd. 100 for \$1.95.  
No. 6 Oil paper, .002 Mfd. to 1 Mfd. 50 for \$2.19.  
No. 7 Auto. Gen. and Distrib. Types, 50 for \$1.69.  
No. 8 Mica, insulated, 35 Mfd. to .1 Mfd. 100 for \$1.95.  
No. 9 Mica Knitting, .0002 to .01, 15 for \$1.39.  
No. 10 Ceramics, 1.0 to 1000 Mfd. 100 for \$1.95.  
No. 11 Trimmers, 1, 2, 3 and sections, 15 for \$1.00.  
No. 12 Filters, Tubular, P.P., cartridge, etc. 10 for \$1.95.  
No. 13 Air Padders, Ass't types and sizes, 10 for \$1.19.

### TRANSFORMERS

- No. 1, Output, P.P., Univ. and sh. 3 to 15W. 10 ass't. \$3.95.  
No. 15 Chokes, 10 to 180 Ma. Ass't Induc. 10 for \$4.45.

### TUBE SOCKETS, ALL NEW

- No. 16 Tube Sockets, All types, 25 Ass't. 89c.

### TERMINAL STRIPS

- No. 17 Assorted styles and sizes, 50 for 89c.

### HARDWARE ASSORTMENTS

- No. 18 Solder lugs, All sizes and types, 3 Lbs. for \$1.29.  
No. 19 Screws, Nuts, Washers, etc. 3 Lbs. for \$1.29.  
No. 20 Aluminum rivets, All sizes and types, 3 Lbs. for \$1.29.

### INSULATORS, CERAMIC

- No. 21 Studs, Spacers, Feed-through, etc. 50 for \$1.79.

### VIBRATOR TRANSFORMERS—6 VOLT

- Motomda, Current Model, 6.8 V, 60 Cyc. New 75c.  
Zenith #163, 150 V.C.T., 60 Ma. Cased—75c.  
Zenith #204, 500 V.C.T., 90 Ma. Un-cased—\$1.29.  
Zenith #198, 500 V.C.T., 65 Ma. Cases, 95c.  
Zenith #208, 150 V.C.T., 60 Ma. Un-cased 69c.

### FILTER CHOKES

- Zenith #197, 10 H, 55 Ma.—2 for 98c.  
Zenith #201, 5 H, 85 Ma.—59c.  
Stancor #301, 3 H, 50 Ma.—3 for \$1.00.  
Stancor #115, 5 H, 125 Ma.—89c.  
Stancor #111, 3.5 H, 180 Ma.—\$1.15.  
Stancor #079, 7 H, 150 Ma.—\$1.29.

### FILTER CONDENSERS

- Sprague—4 Mfd. 800 V.D.C. Square, 4 for 98c.  
C.O.D. etc.—1 Mfd. 600 V.D.C. Rect. 5 for 98c.  
C.O.D. etc.—2 Mfd. 600 V.D.C. Rect. 5 for 98c.  
Aerovox—2 Mfd. 600 V.D.C. Round, 3 for \$1.00.  
Sprague—3 Mfd. 330 V.A.C. Round, 3 for \$1.00.  
Micanoid—10 to 40 Mfd. 250 V.D.C. Round, 2 for 98c.  
Solar—200 Mfd. 10 V.D.C. Round, 2 for 98c.  
Aerovox—500 Mfd. 200 V.D.C. Round, Each \$1.09.  
Indust.—1000 Mfd. 8 V.D.C. Round, 2 for 98c.  
P.P.—3000 Mfd. 3 V.D.C. Round, 3 for \$1.00.

### FILAMENT TRANSFORMERS, (115 V. 60 Cyc.)

- STC #P—40 RMS, Ins. 5000 V. 7.5 V.C.T. @ 24A. Cased with Standoffs, Like New \$5.95.  
CA #B—75 RMS, Ins. 10,000 V. 2.5 V.C.T. @ 20 A. 1 bright case with slide terminals, Like New, Each \$4.50.  
GI, #836—115 V. or 230 V. Prim. Secondary tapped 1.5 V., 8 V., 12.5 V., 16 V., 22 V., 26 V. and 31 V. @ 2 Amps. Cased with Lugs on Bottom, New \$1.95.

### POWER TRANSFORMERS, (115 V. 60 Cyc.)

- P-12 700 V.C.T., 90 Ma.; 5 V.C.T. @ 3 A. and 6.3 V.C.T. @ 3.5 A. New \$2.95.  
P-14 750 V.C.T., 150 Ma.; 5 V.C.T. @ 3 A. and 6.3 V.C.T. @ 3.5 A. New \$4.25.  
P-101 500 V.C.T., 70 Ma.; 5 V. @ 3 A.; 9 V. @ 2 A. New 95c.  
C-59 610 V.C.T., 90 Ma.; 5 V. @ 3 A.; 6.3 @ 2.1 A. \$1.49.  
C-60 1450 V.C.T., 60 Ma.; 5 V. @ 3 A.; 6.3 @ 1.2 A. \$1.79.  
K7-77 1000 V. 78 Ma.; 6.3 @ 2.1 A.; 6.3 @ 3.2 A.; 5 V.C.T. @ 3 A. \$1.79.  
P-202 780 V.C.T., 220 Ma.; 6.3 V. @ 6.5 A.; 5 V. @ 3 A. \$4.50.

### SPECIAL TRANSFORMERS

- S-11 Mike to single grid, Sola Shielded, New 69c.  
S-12 (20,000 ohms) to 11 Z.C., 1.2:1 Throd. Shld. New 69c.  
S-13 to P.P. grids, 1.5:1 Throd. Dist. Shld. New 95c.  
500 Ohms to P.P. grids, Stancor Shld. 12 W. New \$1.49.  
Z-165, Input: 85 to P.P., Sp. 2 for 95c.  
P-175, Modulation: 100 W Prim. Z-121: Sec. Z. 1850 Ohms, Response 3000 Cyc. Like New \$1.75.

### A SUPER VALUE!

An assortment of power transformers, audios, chokes, modulation, line, etc. over 15 lbs. of good usable units, any one of which may be worth much more than the lot price to you! GET YOURS NOW... 10 for only \$3.95.

### BC-604 F.M. TRANSMITTER

25 W output @ 100% modulation. Good condition. Used. Less tubes, crystals and dynamotor. Ship. Wt. Approx. 60 Lbs. Express only. \$6.95.

### ALUMINUM RELAY RACK PANELS

19" wide, Unfinished standard notching.  
16 gauge—(10.5) 10 1/2" high. Each 69c.  
20 gauge—(10.2) 10 1/2" high. Each \$1.19.  
10 gauge—(10.2) 12 1/2" high. Each \$1.59.

### TUNING UNITS

TU-26, 200 500 Kc. \$1.79.  
TU-10, 10 Mc.—12.5 Mc.—\$1.98.  
Ship. Wt. Approx. 17 Lbs. Express only. (Glass cases)

### NEON BULBS

G.E. Type NE 48 1/4 W. Auto bayonet base, 10 for \$1.75.

### TUBE SOCKET AND SHIELD ASSEMBLY

#9 pin miniature, black Phenolic socket, New, Each—21c.

### SUBMINIATURE TUBES

Tribodes Type unknown, Fil: 1 Volt; plate: 45 V. New 3 for \$1.00.

### ANTENNA ROTATING ASSEMBLY

RL-12 Revolvable Motor and Gear Box Magnetic Clutch, 21 V.D.C. or 7.5 Amps. Ship. Wt. Approx. 12 Lbs. New \$2.95.

### FABRIC LOOM

Weather proof. Ideal for sleeving on T.V. and FM Antenna lead ins., thru skylights and around corners. I.D. 1/2", 1" and 3/4". (Specify size) 50 feet, any size—\$1.45.

### NOW !!! BETTER THAN EVER BEFORE !!! OUR ELECTRONIC PACKAGE !!!

Check full of new and different parts and assemblies 10 lbs. of good usable material for only \$1.29. GET YOURS NOW!!!  
Quantities are limited—Order now. Minimum order—\$2.00. There will be a 25c packing charge for all orders under \$2.00. 25% deposit required, balance C.O.D. All orders shipped P.O.B. Chicago, Illinois. Any orders received without shipping instructions will be shipped Railway Express.

### PERMEABILITY TUNER

? I have a battery-powered receiver using a 1R5 converter with conventional capacitor tuning in the antenna and oscillator circuits. I would like to receive the converter circuit to use permeability-tuned antenna and oscillator tuners. Please print a diagram showing how this can be done.—W.A.M., Pana, Ill.

A. Not knowing what type of tuning unit you have, we have drawn circuits of connections for two popular types of permeability tuners. Since most of the component values are identical in these circuits, we suggest you try both to determine which works best in your set.

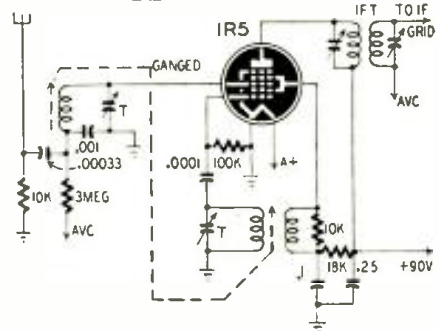
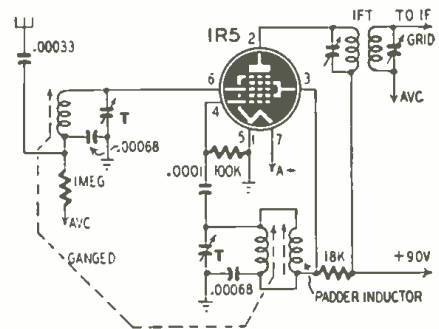

### INDUCTORS FOR COLOR ORGAN

? I am planning to construct the color organ described in the Question Box of the October, 1948, issue. Please print a drawing showing the construction of the tunable inductors L1 and L2.—G.S.B., McKeesport, Pa.

A. The drawing shows how the coils may be constructed. The form is a cardboard or thin plastic tube approximately 3/8 inch inside diameter with end pieces made from wood or other nonmetallic material. The core may be made from lengths of soft iron wire if a powdered-iron core is not available. Select a cardboard tube having an out-

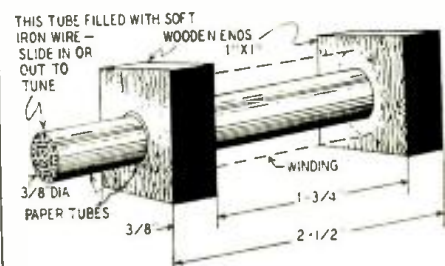

RADIO-ELECTRONICS for

**UNITED SURPLUS MATERIALS**  
314 S. Halsted St. Chicago 6, Ill.



**TELEVISION  
SERVICING at a  
PRICE YOU CAN PAY**

**R. S. E. 3 inch  
TELEVISION SCOPE**

**Features:**

- WIDE BAND VERTICAL RESPONSE
- FLAT TO 750kc
- DOWN 3db AT 1mc
- VOLTAGE GAIN OF 20 AT 5mc



AR-3

The R.S.E., AR-3 Scope has been built by Armstrong to our rigid specifications. It's a complete unit that embodies standard horizontal amplifier and sweep circuits with normal sensitivity.

The case is 8" high x 5" wide x 14" long, attractively finished in "hammered" opalescent blue enamel. Operates on standard 110 volts—60 cycles—40 watts. Tubes, 3BP1—6AC7—6SJ7—6X5—5Y3—884. Instructions included. Complete specifications upon request. Satisfaction or your money back.

PRICE  
**\$49<sup>95</sup>**

F. O. B. DETROIT

**PUSHBACK  
WIRE**



**BELOW MILL PRICES!**

2,000,000 feet—tinned copper—all 1st. class, double cotton serve, waxed finish. Available 1,000 foot rolls.

- 22 gauge (6 colors) \$3.98 roll
- 20 gauge (6 colors) 4.98 roll
- 18 gauge (brown only) 6.49 roll



**OZ4's  
(No Limit)**

Fresh RK and RCA. Standard commercial grade, not JAN's.

BUY 12 **58c**  
get 1 free EACH

EGG CRATE OF 100 **\$49<sup>00</sup>**



**ORDER INSTRUCTIONS**

Minimum order—\$2.00. 25% deposit with order required for all C.O.D. shipments. Be sure to include sufficient postage—excess will be refunded. Orders received without postage will be shipped express collect. All prices F.O.B. Detroit.

**RADIO SUPPLY &  
ENGINEERING CO., Inc.**  
85 SELDEN AVE. DETROIT 1, MICH.

side diameter which will permit a sliding fit inside the coil form. Cut pieces of soft iron wire to the length of the form and dip in insulating varnish. When dry, pack the wires into the smaller tube. Adjust the inductors by sliding the cores in or out.

**RHOMBIC FOR HIGH-BAND TV**

? *There was a diagram of a rhombic antenna for receiving low-band TV stations in the Question Box of the May, 1949, issue. Please give dimensions for a similar antenna for the high band.—W.A.G., Bronx, N. Y.*

A. Dimensions for a high-band TV rhombic are shown on the diagram. The two 390-ohm terminating resistors

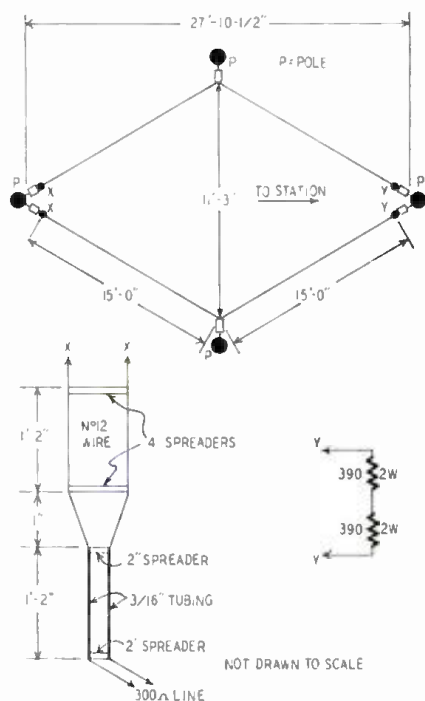

should be mounted in a small waterproof container and connected across the end of the antenna nearest the TV station.

The matching stubs are designed to match the antenna to a 300-ohm transmission line. A 14-inch length of 150-ohm line can be connected between the lower end of the smaller stub and a 72- or 75-ohm transmission line if your receiver is designed for a low-impedance line.

**COMMERCIAL RADIO  
DIAGRAMS**

? *Please send me diagrams of the Atwater Kent model 55C, Majestic model 30, and RCA Victor model 8X541 radio receivers. If you do not have them, please tell me if and where I can obtain them.—L.J.H., Ames, Iowa*

A. We no longer supply commercial radio diagrams. Possibly you can find the diagrams you want in Rider's *Perpetual Trouble Shooters Manual*, Howard W. Sams' *Photofact Folders*, or Supreme Publications' *Most-Often-Needed Radio Diagrams*. Single diagrams may be obtained from John F. Rider.

**RADIO AND TELEVISION TUBES**

STANDARD BEST NUMBERS  
RCA • KENRAD • SYLVANIA • TUNGSO • ETC.  
ALL NEW...MONEY BACK GUARANTEE!

50L6GT	\$ .55
35Z5GT	.39
12SQ7GT	.49
12SK7GT	.54
12SA7GT	.55
50B5	.55
35W4	.39
12AT6	.49
12BA6	.54
12BE6	.55
25L6GT	.69
25Z6GT	.49
6SQ7GT	.49
6SK7GT	.54
6SA7GT	.55
35A5	.79
50A5	.79
35Y4	.69
14A7	.49
14B6	.49
14Q7	.49
OZ4	.54
6X5GT	.49
5Y3GT	.44
80	.39
6AG5	.69
6AK5	.89
6AL5	.69
6J6	.69
6K6GT	.49
6BG6G	1.59

BUY THEM BY THE HUNDREDS  
5% Discount on orders over \$50

**BROOKS RADIO DIST. CORP.**  
80 VESEY ST., DEPT. A, NEW YORK 7, N. Y.

## LEOTONE SPECIALS!

**G.E. UNIVERSAL MOTOR** 110V. AC-DC. Fract. HP. 6000 RPM. 1/2" shaft. Mtg. 2 1/2" x 2 3/4". 3 1/2" high. Shpg. wt. 6 lbs. ea. 3.95  
**G.E. SELBYNS** (22111). New. Shpg. wt. 2 lbs. ea. .98  
**3 RPM HAYDEN MOTORS** 110VAC. 2.2W. 2.49  
**1% PRECISION RESISTORS** (Weston) 155K. 150K. 164.5K. 450K or 800K. ea. 15c; 8 for 1.00  
**TU-17A TUNING UNIT** (16-223) for replacement of a "TOLD MIKE" of the switches, jacks, variometer, etc. (black crackle case 11"x9 1/2"x 3 1/2") Less crystal. Shpg. wt. 8 lbs. 2.95  
**PILOT ASSEMBLY** Faceted Red Jewel. Plated brass housing. Complete with shade & bay. Full. ea. 23c; 5 for 1.00  
**DIAL CORD** Strong, flexible. Nylon. 15 ft. 1.9c  
**DPDT TOGGLE** (11 & 116A 125V. Split ball. ea. 29c; 4 for 1.00  
**FEED-THRU INSULATOR** (IN-200) H.V. duty porcelain 2" O.D. 4" long. Shpg. wt. 1 lb. ea. 39c; 3 for 1.00  
**DM-36D DYNAMOTOR** 24V. DC to 220V AC. 80ma. With filter system. Shpg. wt. 6 lbs. 98c  
**MAST SECTIONS** 35-49. 50. 51. 53 of 54. Shpg. wt. 2 lbs. ea. 39c; 3 for 1.00  
**SCR-511 TECH MANUAL** (Incl. PE-157 power supply) 173 pp.; 50 illus. & diag. .75  
**FREQUENCY METER MANUAL** (TM-173) 58 pp. .25  
**R-89 ARN-5A SCHEMATIC** .25

**T-32 DESK MIKE** BRAND NEW. Shpg. wt. 2 lbs. 2.95  
**T-44A MIKE** Twin-magnet type. Shpg. wt. 2 lbs. BRAND NEW .69  
**T-30 THROAT MIKES** BRAND NEW. Shpg. wt. 1 lb. ea. 39c; 6 for 1.00  
**RS-83 CARBON MIKE** BRAND NEW with cord, press-to-talk switch & plug. 1 1/2" O.D. bakelite case. Shpg. wt. 1 lb. 98c  
**BACK AGAIN BY POPULAR DEMAND!!!**



**LEOTONE'S "JUMBO RADIO PARTS KIT"**  
 To You RADIOHOMES who want the most for your money, 17 LBS. of the BIGGEST & BEST assortment of new & dismantled TRANSFORMERS, COILS, HARDWARE, WIRE, SOCKETS, RESISTORS, SPEAKER ACCESSORIES, CONDENSERS, ETC. All these (shpg. wt. 21 lbs.) & much more FOR ONLY 2.95  
**AN-74A BLADE ANTENNA** for SCR-522. Shpg. wt. 5 lbs. 89c  
**POWER RHEOSTATS** New standard brands. 50W-15 ohm. 85c; 50W-50 or 75W ohm 1.25; 25W-25, 100, 50, 200, 250 or 370 ohms .75  
**RADIO HARDWARE TREASURE** A FULL POUND of Screws, Nuts, Washers, Lugs, etc. In HANDY SELF-SEALING HINGED LID 49c  
**METAL CAN** Shpg. wt. 2 lbs. Self-starting. 110V. AC INDUCTION MOTORS 1.25  
**1750 RPM. Fract. HP. 2 3/4" O.D.** 2" deep. Shpg. wt. 2 lbs. 1.25  
**AUTO SUPPRESSORS** Universal elbow type for either Plugs or Distributor. ea. 8c; 18 for 1.00  
**P-23 HEADPHONES** 5 ft. cord & PL-55 1.29

**REPAIR YOUR OWN SPEAKERS WITH THESE PROFESSIONAL KITS!**  
**SPEAKER REPAIR KIT**—A really "BIG" kit in savings & convenience. Contains: 25 ass'd. mtg. rings, 10 spiders, 25 voice coil forms, 3 yds. felt strip, 20 channels leather segments, kit or 16 shims, tube speaker cement. With instructions. Shpg. wt. 5 lbs. 2.49  
**SPEAKER CONE KIT**—A LEOTONE SPECIAL! TY SINCE 1927. Handy assortment of 4" to 12" top quality moulded & free-edge (magnetic incl.). Less voice coils. Kit of 12 2.00  
**SPECIAL BARGAIN OFFER—BOTH 3.95**  
 "REPAIR & CONE" KITS FOR ONLY

**ALNIC MAGNETS**—New "EXPERIMENTAL KIT" 10 ass'd. powerful Bar. Block. "C", Circular etc. Shpg. wt. 2 lbs. 1.98  
**4 TUBE AMPLIFIER FOUNDATION** Ideal for any small electronic unit. Black crackle cabinet & slide-in chassis contains: power trans., condensers, resistors, sockets, etc. 8 1/2" x 12" x 3 3/4". Shpg. wt. 4 lbs. A REAL BUY AT 98c  
 Min. Order \$2.00—20% discount required on COO's. Please add sufficient postage. Excess refunded.  
**GET ON OUR MAILING LIST**  
 ALWAYS SOMETHING NEW  
**FACTORY REPAIR SERVICE ON ALL SPEAKERS**

**LEOTONE RADIO CO.**  
 MAKERS OF CONES AND FIELD COILS  
 65-67 DEY STREET, NEW YORK 7, N.Y.  
 WORTH 2-0284-5  
 12,000 SQ. FT. OF RADIO PARTS

### NULL DETECTOR

Patent No. 2,458,310  
 Carl G. Sontheimer, Stamford, Conn.  
 (assigned to Radio Corp. of America)

Designed especially for direction finders, this detector is also suitable in bridges. The electron-ray indicator is sensitive and more rugged than a meter.

An incoming signal is picked up by a rotatable loop. The receiver uses a heterodyne oscillator to provide an audio beat. Headphones are used while tuning the signal for maximum. The 6SJ7 detector is biased by potentiometers P1 and P2, which are coarse and fine adjustments, respectively.

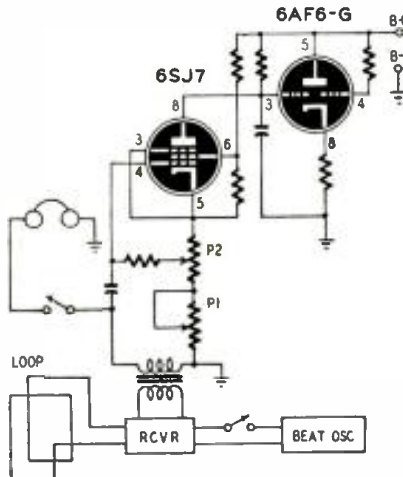

The detector is direct-coupled to one section of the indicator tube. The other is not used; therefore its control element is connected to B-plus through a resistor which drops the voltage just enough to close its corresponding shadow.

When a strong signal is received, the detector  $I_p$  is maximum and  $E_p$  is low. Therefore, the shadow on the controlled section of the indicator is nearly 90 degrees. As the loop is rotated (for minimum) signal, the shadow is reduced. At null the shadow is practically zero.

### OSCILLATOR-DOUBLER

Patent No. 2,459,262  
 Alan P. Buffington, Philadelphia, Pa.  
 (assigned to Philco Corp.)

The local oscillator of an FM receiver usually operates at a frequency near 100 mc. It is difficult to design an oscillator which is stable and uniform at this high frequency over the entire range. It is preferable to add a doubler so that the oscillator stage can be designed for frequencies near 50 mc.

This system has not been widely used in broadcast FM receivers, but local oscillator-doubler circuits are often used in mobile u.h.f. superhets to obtain better stability and uniformity over the tuning range.

In the schematic shown here, tank circuit O tunes the oscillator. It is coupled to the grid-plate

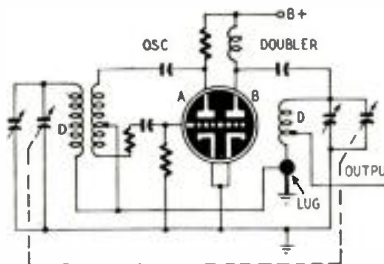

coil of triode A. Tank D tunes the doubler stage, triode B. The two tuning capacitors may be ganged as usual for single-dial tuning. A and B may be separate triodes or a double triode such as the 7F8.

An important part of the invention is the feedback connection between stages. The cold terminals of the oscillator coils and the doubler coil are tied together at a lug. The soldered point is about 3/8

## FOR FM-AM MODEL 705 A SIGNAL GENERATOR



### DOUBLE MODULATION 30% & 80%

Not one—but two percentages of modulation add greater checking performance to your service tests. All exclusive feature in this low price precision generator. Fully dependable. Excellent for FM alignments.

An Exceptional Value for only **\$49.50** Complete

- Range from 95 kc. to 100 mc. • Fundamental frequencies in 5 bands, continuously variable
- Accurate to 2% for broadcast bands—3% for h.f. bands • Planetary drive condenser with accurate double and tuning indicator • 5 step ladder attenuator controls voltages from 0 to maximum • Covers all new FM bands—useful signals can be obtained as high as 150 mc. • Negligible leakage due to complete shielding • Complete, ready for the shop. Just plug in any standard 110 V., 60 Cycle A.C. line and go to work • Grey hammetone case—portable, only 11 lbs.

Write for Catalogue 3M

**RADIO CITY PRODUCTS CO., INC.**  
 152 West 25th St. New York 1, N. Y.

## TELEVISION ANTENNA INSTALLATION

A PRACTICAL BOOK  
 THAT SHOWS YOU  
 STEP BY STEP



Proper antenna installation can do as much for a television receiver as a special booster. And unless you get the signal into your set, even the most expensive receiver will function poorly. TELEVISION ANTENNA INSTALLATION covers every phase of installing a TV antenna showing how to get the most out of every installation. Every step is clearly and simply explained. The approach is completely practical. Nothing is left to your imagination, and NO PREVIOUS EXPERIENCE NEEDED.

OVER 100 PAGES \$1.50  
 MORE THAN 100 ILLUSTRATIONS

Consolidated Publications,  
 55 East Washington Street,  
 Chicago, Illinois

Enclosed find (check) money order for \$.....  
 Send C.O.D. (no C.O.D.'s outside U.S.A.) and I will pay postman this amount plus a few cents postage. In either event, I may return books within 10 days for complete refund of my remittance.

Name.....  
 Address.....  
 City..... (Zone No.).....  
 State..... RE-1



The big book that shows you how!



Cash in on TV SERVICING PROFITS!



Price only \$4

**PRACTICAL TELEVISION SERVICING**

By J. R. Johnson and J. H. Newitt  
375 pages, 6 x 9, over 230 illustrations

Get where the big servicing money is—in television! Now is the time to prepare for this fast-growing business—and here is the book that makes the training far easier and faster than you may have thought possible! PRACTICAL TELEVISION SERVICING is a complete, down-to-earth guide that tells you step by step just what to do, what mistakes to avoid, what tools, parts, and equipment to use—in short, how to handle every phase of television receiver servicing promptly and efficiently.

**COMPONENTS — CONSTRUCTION OPERATION — TROUBLESHOOTING SERVICING**

PRACTICAL TELEVISION SERVICING isn't a book of mere theory and mathematics. It is a practical, how-to-do-it handbook by two well-known engineer-authors who actually owned and operated a TV service shop. Besides outlining how television differs from radio, they explain TV troubleshooting and service procedure from installations to synchronizing units; from erecting and orientation of antennas to remedying image distortion. Case histories of actual TV service jobs plus descriptions of common TV troubles and their cures make the book doubly helpful and easy to understand.

- MAKES TV SERVICE EASY TO LEARN**
- Here are the subjects covered:
1. Television is Here
  2. Fundamentals of the Television System
  3. Radio-frequency, Intermediate-Frequency and Detector Sections
  4. Video Amplifiers
  5. Cathode Ray Tubes
  6. Synchronizing and Sweep Circuits
  7. Power Supplies
  8. Antennas and Wave Propagation
  9. Television Receiver Installation
  10. Test Equipment and Alignment
  11. Wiring and Repair Techniques
  12. Common Troubles in Television Receivers
  13. Troubleshooting
  14. Servicing Hints and Case Histories
  15. Color Television
    - A. Intermediate Frequencies of Standard Receivers
    - B. Receiver Layout Diagrams
    - C. Glossary

**MONEY SAVING TIPS ON**

— testing for intermittent breaking coils or transformers — improving picture linearity — geying masts — getting a signal over a mountain — checking video response with a square wave—using mica capacitors to replace other types—choosing components — wiring techniques... and scores of other practical problems.

... an excellent text for both student and practicing television serviceman. JOURNAL OF THE FRANKLIN INSTITUTE.

... the section on TV receiver installation alone is well worth the price of the book. RADIO ELECTRONICS

**5-DAY MONEY-BACK GUARANTEE**

Dept. RE-99, MURRAY HILL BOOKS, Inc., 232 Madison Ave., New York 16, N. Y.  
 Enclosed find \$4 (\$4.50 outside U.S.A.) for a copy of PRACTICAL TELEVISION SERVICING or  send C.O.D. for this amount plus a few cents postage. (No foreign C.O.D.'s.) In either event, if the book is unsatisfactory, it is understood I may return it in 5 days and you will refund my \$4.

Name .....

Address .....

City & Zone ..... State .....

inch from the chassis and is quite critical because of the inductance of the lug at these frequencies.

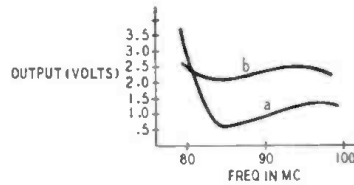

By way of comparison, curve b shows the output obtained from this circuit. Curve a is the output from conventional oscillator-doublers.

**DOUBLE LIMIT BRIDGE**

Patent No. 2,468,625  
Lawrence R. Goetz, Indianapolis, Ind.  
(Assigned to P. R. Mallory & Co., Inc.)

Limit bridges are used in manufacturing plants and electronic industries to check resistors. Two measurements are generally made. One indicates whether a resistor is below its upper limit. The other checks whether it is above its lower limit.

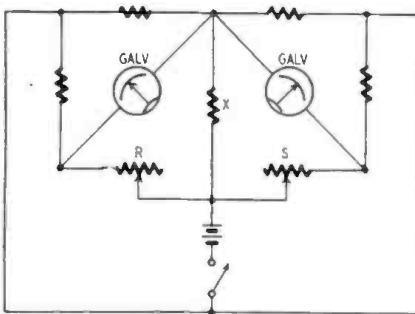

A recently developed double bridge saves time by allowing both limits to be checked at the same time by using two galvanometers and two bridges, connected as shown. The unknown resistor X is common to both bridges. Variable elements R and S are adjusted to the required limits, for example +5% and -5%, respectively. Each meter is calibrated in terms of REJECT and ACCEPT. If both indicate ACCEPT, the resistor is within its limits.

**TUNING INDICATOR**

Patent No. 2,468,197  
Jarrett L. Hathaway, Manhasset, and Ralph C. Kennedy, Orangeburg, N. Y.  
(Assigned to Radio Corp. of America)

A neon or other gas-filled lamp makes a good indicator for transmitter tuning. It saves space and is less expensive than a meter.

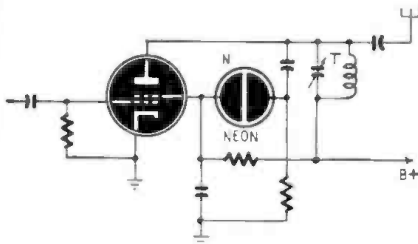

There are two main adjustments to be made on the final stage of a transmitter. The first is to align the preceding stages so that maximum power is delivered to the final grid. The second is to resonate the final plate. Both can be done with the aid of a neon lamp N connected as shown.

When the grid receives maximum r.f., its bias is greatest. Therefore, the screen current is low; this is indicated by a minimum glow of the lamp. When the final tank T is resonated, maximum r.f. appears on the plate. Since the lamp is coupled to the plate by a capacitor, it glows brightest with correct tank tuning.

In practice the preceding stages are first adjusted (by noting minimum glow). Then the final tank is tuned by watching for maximum brilliance.

**TEICO PRESENTS**

**OUTSTANDING PRECISION INSTRUMENT KITS**



**MODEL 221-K VTVM KIT**

Build this High-Precision Vacuum Tube Voltmeter. 15 different ranges! AC and DC ranges: 0.5/10/100/500/1000 volts. Ohmmeter range: 2 ohms to 1 megohm. Zero Center for TV discriminator alignment. Big 4 1/2" meter cannot burn out. Double triode balanced bridge circuit assures stable, guaranteed performance. 110-130 V. AC. 50-60 cycles. Size 9 7/16" x 6" x 5 7/8". **FACTORY-WIRED VTVM Model 221. Same, but completely wired, calibrated, and tested \$49.95**



**You Build 'Em In One Evening—THEY LAST A LIFETIME!**

**5" SCOPE KIT**

Model 400-K. Laboratory precision scope, for FM, AM & TV servicing. Deflection sensitivity: .65 volts per inch, full gain. Horizontal sweep circuit, 15 to 30,000 cycles. Frequency response of horizontal and vertical amps is from 50 to 50,000 cycles. Graph screen. Operates on 110 to 130 volts AC, 50-60 cycles. 3-color etched, rip-proof panel. Size: 8 1/4" x 17" x 13" high. 3-color etched panel



**FACTORY-BUILT OSCILLOSCOPE Model 400. Fully wired, assembled, and tested. \$69.95**

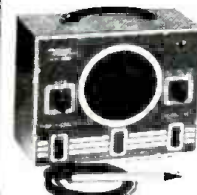

**MULTI-SIGNAL TRACER KIT**

Model 145-K. High-gain, high-frequency instrument. Internal speaker beams audio signal tracing of RF, IF, FM, audio, and video circuits. Visual tracing with VTVM. Response over 200 mc. 110-130 V. AC. Size 10" x 8" x 4 1/2". Complete with amplifier. 3-color etched panel

**FACTORY BUILT AND TESTED Model 145. Ready to operate \$28.95**



**SIGNAL GENERATOR KIT**

Model 320-K. For service lab. and school use in FM-AM alignment and to provide TV marker frequencies. Ceramic insulated variable condensers. Highly stable Hartley oscillator has range of 130 kc to 100 mc with fundamentals to 31 mc. Outputs audio oscillator supplies pure 400 cycle sine wave voltage for modulation. Large 6" dial. Easy-to-read calibration. Easily aligned. Complete with tubes. 10" x 8" x 4 1/2". 3-color etched panel

**FACTORY WIRED AND ALIGNED Model 320. Ready to use \$29.95**

**SEE THESE INSTRUMENTS AT LOCAL JOBBER**

Complete simplified instructions and illustrations come with every EICO Instrument Kit, making it pure enjoyment to build your own equipment. Nothing more to buy. Anyone can build it. Write for catalog.

**ELECTRONIC INSTRUMENT CO., INC., 276 NEWPORT STREET BROOKLYN 12, N. Y.**

# Try This One

## SIMPLE DIAL CORD TOOL

One of the most handy tools I have ever used for stringing dial cords is a simple hook and eye bent from a piece of No. 16 wire about six inches long. Drawing A shows its construction.

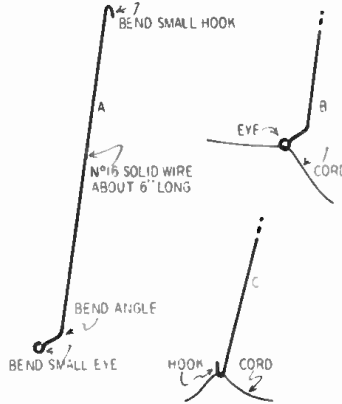

tion. B shows how the dial cord can be threaded through the eye and carried wherever you want it without the danger of its dropping into some hard-to-get-at place. Drawing C shows how the hook can be used to retrieve the cord from a tight spot.

ARTHUR TRAUFFER,  
Council Bluffs, Iowa

## SAVING PLATE BYPASS CAPACITORS

Most manufacturers return the power amplifier plate bypass capacitor to the cathode or to ground. This practice puts high audio voltages across the capacitor and makes it necessary to use high-voltage units. Most manufacturers use 600-volt capacitors in this application. Even these break down and cause serious damage to the set.

Try lifting the lower end of the capacitor off the cathode or ground and connecting it between the plate and screen grid. The voltage across the capacitor will be much lower and it is less likely to break down.

C. W. BLATCHLEY  
East Freehold, N. J.

## HANDY CONNECTORS

Many multicontact sockets and female connectors in surplus equipment make good selectors for capacitor and resistor decade boxes. In most cases, you will be able to find connectors which will take pin tips, phone tips, or small banana plugs.

O. C. VIDDEN,  
Fertile, Minn.

## ATTENTION Amateurs-Experimenters-Inventors

Cut your cost on radio supplies and equipment in half. Clip coupon today.

Hundreds of "hard to get" war surplus items along with the best in standard brand equipment—all at great savings to you. Let us know your particular requirements. IMMEDIATE DELIVERY.

PLEASE PUT MY NAME ON YOUR MAILING LIST FOR SPECIAL BULLETINS.

NAME.....  
ADDRESS..... ZONE.....  
CITY..... STATE.....

**NIAGARA RADIO SUPPLY CORP.**  
160 Greenwich St., New York City 6, N. Y.

## OPPORTUNITY AD-LETS

Advertisements in this section cost 25¢ a word for each insertion. Name, address and initials must be included at the above rate. Cash should accompany all classified advertisements unless placed by an accredited advertising agency. No advertisement for less than ten words accepted. Ten percent discount for six issues, twenty percent for twelve issues. Other favorable or misleading advertisements not accepted. Advertisements for October, 1949, issue, must reach us not later than August 24, 1949.  
Radio-Electronics, 25 W. Broadway, New York 7, N. Y.

WE REPAIR ALL TYPES OF ELECTRICAL INSTRUMENTS, tube checkers and analyzers. Hazleton Instrument Co. (Electric Meter Laboratory), 110 Liberty Street, New York, N. Y. Telephone: RAvelay 7-4239

24 VOLT AIR-RAFT BATTERIES, NEW 11 AMP AT 5 hr. rate. Dry charged \$14.50 ea. less 25% in lots of four. No C.O.D.'s please. Security Parachute Co., Oakland Airport, Oakland, Calif.

LANCASTER, ALLWINE & ROMMEL, 435 BROWN Building, Washington 5, D.C. Registered Patent Attorneys. Practice before United States Patent Office. Validity and Infringement Investigations and Opinions. Booklet and form "Evidence of Concealment" forwarded upon request.

AMATEUR RADIO LICENSES. COMPLETE THEORY preparation for passing amateur radio examination. Home Study and resident courses. American Radio Institute, 801 West 63rd St., New York City. See our ad on Page 78.

HERMAN LEWIS GORDON, REGISTERED PATENT Attorney, Patent Investigations and Opinions, Warner Building, Washington, D.C.

MAGAZINES BACK DATES—FOREIGN, DOMESTIC, arts, books, booklets, subscriptions, pin ups, etc. Catalog. Be. (Incl. ad), Circulation, 363 First Ave., New York 17, N. Y.

BARGAIN HUNTING? RADIO SERVICE MEN WRITE. Sensational catalog. Henshaw Radio Supply, 3619 Trust, Kansas City 3, Missouri.

27 Years experience radio repairing. Simplified system. No calculations. No formulas. Total price \$2.00 postpaid or C.O.D. Moneyback guarantee. Russ Radio, 1465 Grand-avenue, Detroit 27, Mich.

Aluminum tubing, etc. Complete Beam for Amateurs. TV, FM. Lists free. Willard Radio, Easton, Ohio.

BEGINNERS. Valuable experimental data free. Catalog. Laboratories, 578 E. San Gabriel, California.

GEORGE LOEBNER KITS. COMPLETE PARTS LIST and schematic. Free. Write Daily Woodland 5217 G Hollywood Boulevard, Hollywood 27, California.

TELEPHONE DIALS. N.E. Type-1 Rebuilt \$2.25. Re-adjusted \$1.25. All dials postpaid in U.S. Kissel Electric Products, 131 C Sherman, Galton, Ohio.

101 RADIO REPAIRING TIPS (BOOKLET). SEND 50 cents. U.S. Radio, 135 E. 28 St., New York 16, N. Y.

BARGAINS: NEW AND RECONDITIONED BALL-CRAFTERS, National, Collins, Hammarlund, Meissner, RME, other receivers, tuners, television receivers, transmitters, etc. Wholesale prices. Terms: Shipped on trial. Liberal trade-in allowance. Write Henry Radio, Butler, Missouri and 11210 West Olympic, Los Angeles, California.

FOR SALE. RADIO AND ELECT. SHOP. Only Service man in county. (Must Sell "Sickness," Bargain, Box 63, Owingsville, Ky.)

## WANTED

The following old E.I.C. apparatus:  
E.I.C. Fixed condenser (in wooden box, with 3 binding posts)  
E.I.C. 17 Slide plate, variable condenser (with wooden frame)  
E.I.C. Battery potentiometer (in black molded case)  
E.I.C. Plastic cathode fixed condenser .0165 mf (with 2 binding posts)  
E.I.C. double slide tuner with black molded ends  
All above were made between 1905 & 1910  
Please communicate with  
**H. GERNSBACK**  
25 West Broadway, New York 7, N. Y.

## 500 FORMULAS TO SUCCESS

MANY million dollar firms started with a single formula, for which they paid a big price. Here you have 500 such less-tried and tested formulas, recipes and processes for making things that sell at the ridiculously low price of 25¢. Here is your opportunity to start a business with but a few dollars' investment and with unbounded profit in prospect. You can also use these household formulas to the home. Or you can put them to use in your workshop to cut costs as much as thirty percent.

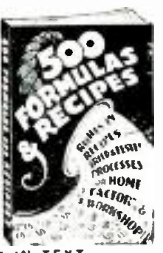

Send for "500 FORMULAS AND RECIPES" today. Enclose 25¢, that's all! You won't be asked for another cent now or later. Sold on a moneyback guarantee.  
**NATIONAL PLANS COMPANY**  
1966 R Broadway, New York 23, N. Y.

RADIO-ELECTRONICS for

Smart Servicemen Say:  
**CASH IN NOW!**  
on Senco's  
**LOW-LOW PRICES**

To Make Big Profits in the  
Busy Service Season

## TUBES

YOU'RE SURE TO NEED  
PRICED EXTRA LOW!

IMMEDIATE DELIVERY!  
INDIVIDUALLY CARTONED  
GUARANTEED!

Special Discount! DEDUCT 5¢ from each tube when ordering 25 or more assorted tubes.

19¢ each	6S07GT	6S17GT	6D6
57A5	6S8GT	6SN GT	6F6G
1044	6X5GT	6V1	6L5G
V99	6X5GT	6V6G	6Q7G
X99	12A7GT	7A4 XXL	6S7
29¢ each	12A6	7A5	677G
2A7	12J7GT	7B6	7A7
2X2	12K7GT	7C5	7C5
6C4	12Q7GT	7F7	7Q7
6CRG	12SA7GT	12A76	12BD6
6SH7GT	12SF5	12BA6	12E8
6SR7GT	12SH7GT	12BE6	14BE
U7G	12S7GT	12S7GT	25AC5
TY4	12SN7GT	21L6GT	50C6
12A6	12SQ7GT	21L7GT	21S6
12ARGT	12TR	54	20J1
12F3GT	21A	5Z4GT	59¢ each
12H6	25Z6GT	6Z4	02A
26	32	46	12A
36	32	46	1L6G
39¢ each	5 31	50L6GT	1LD3
1A3	53L6GT	6Y6G	1LE3
104	w4	33	1LH3
1U	z	36	1N6G
1V	z6	11723	1T4
2A6	47 66	4A6	4A6
3A4	1B5	5V4G	5V4G
3U4G	7	1A5GT	6B F6
5W4	74	1A6	6B6G
2X4G	78	1A7GT	6BH6
5Y3G	80	1C5G	6J8G
5Y3GT	83	1C7G	6U5 6G5
5Y4G	84	1D7G	6W4
6AF5G	84	1D8G	6W6
6AH4	5.¢ each	1E7G	6Y3
6AT6	87 2N5	1F5	12A
6AU6	1L4	1G6G	12A7
6BA6	1R4	1G6GT	14A7
6BE6	1R4	1H4G	14Q7
6C5GT	1R5	1H4G	22
6C6	1T3GT	1H5GT	70L7GT
6F6G	2A3	1H6G	483
6H6GT	2B6	1I6G	69¢ each
6J7	1B7	1R4	6AC7 1852
6K6GT	6.1L5	206	6AK5
6K7G	6B16	304	11726GT
6K7GT	6D7	3V4	89¢ each
6N4	6F3GT	3Z3	1B3GT 8016
6SA7GT	6G5GT	1Z4	5R4G
6SD7GT	6P3GT	6A6	6L6G
6SF5GT	6R7GT	6A05	
6SJ7	6S7GT	6B8	
6SK7GT			

## G.I. RECORD CHANGER

Changes 12 1/2 inch and 10 1/2 inch records automatically. Complete set on crystal cartridge unit. 110 V. 50 cycle. **\$10.95**

ENTER Senco's CONTEST  
"MY FUNNIEST EXPERIENCE"  
IN THE RADIO SERVICE BUSINESS

Win Cash & Other Valuable Prizes... Nothing to Buy. Any Serviceman Can Enter. 12 Monthly Prizes! It's easy as changing a tube! Have lots of fun telling other servicemen about your funniest experience. You're making an education for yourself. You don't have to buy anything! Write us for FREE contest rules.

Minimum Order \$2.50; Send 25¢ deposit for all C.O.D. shipments. Include sufficient postage—excess will be refunded. Orders without postage will be shipped express collect. All prices F.O.B. New York City.

WRITE FOR FREE "SENCO SPECIALS OF THE MONTH" BULLETIN. INCLUDES ALL EXCITING DATA ABOUT OUR NEW CONTEST!

**SENCO RADIO INC.**  
Dept. M, 73 West Broadway  
New York 7, N. Y. Tel. BEekman 3-6498



**SURPLUS PRICES SLASHED!**

**Dynamotor D-2**

D-2 Converts to 110 V AC in ten minutes, diagram included, contains integral gear box having four 1/4" drive shafts turning simultaneously at the following speeds:  
 4000 RPM—Grinders, buffers, flexible shaft tools, etc.  
 150 RPM—Wrapping fishing rods, slow speed tools.  
 25 RPM—Dev. tray rocker for photo darkroom.  
 5 RPM—Turning barbecue snits.  
 Adv. Disp. Beams Thousand Other Uses Around the Work Shop. **\$5.95 ONLY**

**DYNAMOTOR D-1**

D-1 Converts to 110 V AC in ten minutes, diagram included, has shaft with squirrel cage blower, also gear reducer with 2 shafts and pulleys at the other end. 1001 uses. **\$4.95 NEW**

**RM-29 PORTABLE FIELD TELEPHONE**

An ideal portable field telephone. Complete in a rugged steel case for years of wear. Ringer circuit and FS-13 handset. No leather case to deteriorate. Compact "5x5x3" also used as remote control on SCR-281. Simple two wire operation. 15 miles distance and upwards. Can be used for television installation. Intercom system, construction comparable to table and inside work, etc. Light weight, 13 lbs. Excellent condition. **\$9.95**  
**SPECIAL LOW PRICE EACH 2 for \$18.95**

**PLUGS and CONNECTORS 49c each**  
**YOUR CHOICE for only**

- For the SCR-522 ..... PLQ-167, PL-172
- For the BC-318 ..... PLQ-163
- For the RC-733 ..... PLQ-254
- For 250-F Radio Compass Inverter, PL-3108-22-48
- For the SCR-274-N  
 PL-147, 148, 151, 152, 153, 154A, 156, 258
- For the BC-375 ..... PL-59-PL-61-PL-64
- For the ART-19 ..... U-8U, U-101, U-101A
- For the ARC-1 ..... U-151, U-161
- MC-203A coupling Coax Fittings  
 PL-259A (83-18P)-UG-21U-UG-22U  
 PL-164 M-359 U-11/U
- AN-3108-28-191  
 AN-3108-128 } Combination Male and  
 AN-3100-128-33 } Female
- PL-63 SQ-14 1-.62
- PL-56 SQ-86

**BC-733 D**

A 10-tube superhet receiver for lateral blind landing guidance (CAA type certificate) TC-1015. Excellent condition 108-110 MC. Tube complement: 1-12SQ7; 2-12A8; 1-12A9; 1-12AH7GT; 2-12SQ7; 3-717A—tubes alone worth more than this **\$4.95**  
 low price. SCHEMATIC FURNISHED Each

**AN/CRW-2 V.H.F. RECEIVER**

6 tubes: 3-6SL7, 1-6SN7, 1-6SG7, 1-6J5 Dynamotor, plug-in coils and sensitive relays. This was one of the Army's "Secret" V.H.F. remote control receivers. Operating at about 110 MC. A thousand and one uses. Like new in a metal case. **\$4.95**  
 Each

**COMPLETE BEAM ROTATOR ASSEMBLY LP-21A AND 1-82A**

A large 5" indicator 1-82A, brand new and an LP-21 loop (removed from aircraft). A complete perfect beam rotator system with indicator. Loop is low impedance—contains self-transmitter, etc. Loop alone .....\$5.95 Indicator alone.....\$4.25

**FILAMENT TRANSFORMERS**

Fully shielded Fil. 100 V. Sec. (2) winding 10.2 V @ 5 A. C. T. #2 winding 10.2 V @ 10 A. C. T. Secondary winding can be connected in series to supply 25 V. with a line Voltage of 115 Volts— **\$2.95**  
 60 Cyc. New. Each.

**4 VOLT MOTOR**

A real beauty, removed from aircraft. Type used for auto fan. Each. **\$1.59**

**BC-433G**

15-tube superhet radio compass receiver 200 to 1750 Kc; CW-tone-voice. Like new. Similar to R5/ARN7. Only **\$19.95**

**TUBES**

- 1625 ..... 3 for \$1.20
- 6V6 ..... @ .49
- 3D6 ..... @ .49
- 58P1 Scope tubes @ \$2.50
- 58P4 Scope tubes @ 3.45
- 35Z5 @ .59

**6" PM SPEAKER**

Beautiful new stock. Alnico magnet. Each **\$1.95**

**T-17 D MIKE**

The desirable single button carbon mike. With press the button to talk switch. 4' cord and PL-68 plug. mike cover. Features non-echo effect. New **\$2.49**

**DM-53A DYNAMOTOR**

24V. in. 220V-80M.A. out. used, good condition. **\$1.39**

WRITE FOR NEW CATALOG  
 Minimum order \$2.00. F.O.B. Chicago  
 20% deposit required on all C.O.D. orders

**NESCOP ELECTRONICS, Dept. C**  
 2635 W. Grand Ave., Chicago 12, Ill.



LIST PRICE  
**\$67.50**



Multi-Impedance Switch for Low, Medium or High Impedance.

Each OF THESE MICROPHONES HAS THE **SUPER-CARDIOID** PICKUP PATTERN THAT REDUCES FEEDBACK BY **73%**

**THE FAMOUS "55" UNIDYNE DYNAMIC**

Unidirectional Microphone. This superlative dynamic microphone is a Multi-Impedance Microphone—you can have either High, Medium, or Low Impedance simply by turning a switch! Because it is a Super-Cardioid, the "Unidyne" kills Feedback energy by 73%—making it possible to use under the most difficult acoustic conditions. The "Unidyne" is probably the most widely used microphone throughout the world. Recommended for all highest quality general-purpose uses.



**THE NEW "737A" MONOPLEX CRYSTAL**

Unidirectional Microphone. The "Monoplex" is the **ONLY** Super-Cardioid Crystal Microphone made. As such, it is undoubtedly the finest of all crystal microphones. (A comparative test will prove this statement convincingly.) The "Monoplex" employs the same type of acoustic phase-shifting network used in the highest cost Shure Broadcast Microphones. Has "Metal Seal" crystal—will withstand adverse climatic conditions. Can be used in those applications where severe background noise would make conventional microphones practically useless!

LIST PRICE  
**\$39.75**

Licensed under patents of Brush Development Company. Shure patents pending.

**SHURE BROTHERS, Inc.**



Microphones and Acoustic Devices

225 West Huron Street, Chicago 10, Illinois • Cable Address: SHUREMICRO

# MID-AMERICA'S UNBEATABLE LOW PRICES

## WARD ALL-CHANNEL TV ANTENNA



**TVH-9**  
Regular \$26.50

NOW ONLY  
**\$6<sup>25</sup>** Each

MA-3130

TVH-9 covers all channels; high and low bands separately adjustable. Complete with most universal mounting brackets, hardware, instructions, etc. Order while they last! Compare our low prices!

— More Ward TV Bargains —

MA-3131	TV 28	41 to 88 MC	\$2.95
MA-3132	TV 28	41 to 88 MC	2.49
MA-3133	TV 28	41 to 88 MC	2.49
MA-3134	TV 28	17 to 216 MC	2.95

(Write for quantity prices on all WARD TV antennas above)

### Famous-Make Model 50 ANTENNA CHIMNEY MOUNT

Sturdy all metal mount fits any average size chimney. No guy wires required. Complete with hardware and instructions. Save over 50% on this item!

MA-3135 ... \$1.75

— 300-Ohm Twin Lead —

Don't miss this great buy! Standard 300-ohm lead in for TV and FM. Buy in quantity and save!

MA-3136	per 100 ft.	\$13.25
	per 100 ft.	1.40
	per foot	.02

## Write For BIG BARGAIN BULLETINS

### GENUINE RCA TV PARTS



- A. MA 2541 Type 20T2 Vertical Output Trans. \$1.95
  - B. MA 2542 Electro Magnetic Ion Trap .69
  - C. MA 2543 Type 20210 Focus Coil 1.95
  - D. MA 2544 Wired socket for 6BP4, 7BP4, 12BP4 and similar tubes. 31
- 10% discount on any of the above items when ordered 10 or more at one time.

### RCA & MAGNAVOX SPEAKERS

- MA 2715 12" Dynamic B-A; 100 ohm field. P.P. 6V4 output trans. \$3.95 each; \$3.55 each, lots of 4.
- MA 2716 12" Dynamic B-A; 150 ohm field. P.P. 6V4 output trans. \$3.55 each; \$3.55 each, lots of 4.
- MA 2717 8" PM Magnavox; 21 oz. Alnico 3 magnet. \$4.20 each; \$3.09 each, lots of 8.
- MA 2720 12" PM Magnavox; 21 oz. Alnico 3 magnet. \$4.29 each; \$4.00 each, lots of 4.

— Buys in Cabinet Hardware —

- A. MA-3400 Lip Lift .79c
- B. MA-3401 Piano Hinge; 18" long .29c
- C. MA-3402 Black bakelite handle; 6" over-all.
- B 32 threaded inserts on 5/16" ctrs. 5c each, 10 for 48c

### ORDER FROM THIS AD!

All prices f.n.b. Chicago. 25% deposit required on C.O.D. orders, pay balance plus postage on delivery. Send orders to Desk E-99. Minimum order \$2.50.

## MID-AMERICA CO. Inc.

STORE: 2412 S. Michigan Ave. Chicago 16, Ill.  
WAREHOUSE: 2307 S. Archer Ave. Chicago 16, Ill.

## Radio Thirty-Five Years Ago In Gernsback Publications

### HUGO GERNSBACK

#### Founder

Modern Electric	1908
Electrical Experimenter	1913
Radio News	1919
Science & Invention	1920
Television	1927
Radio-Craft	1929
Short-Wave Craft	1930
Television News	1931
Wireless Association of America	1908

Some of the 1935-1936 issues of the July 1934 issue of the ELECTRICAL EXPERIMENTER on file for 1935-1936.

### SEPTEMBER 1915 "ELECTRICAL EXPERIMENTER"

Long Distance Submarine Telegraphy and Telephony  
Sayville, the News-Way to Berlin  
The Hammond Radio Controlled Torpedo Boat  
European Applications of Wireless

Telephony, by Frank C. Perkins  
Wireless Aids Telephone System  
The Hytone Spark Gap  
Some Remarkable Results With Audion Amplifiers, by John A. Gardner and E. R. Isaak

A New Radio Variable Condenser Wireless and Mind Reading  
A "Permanent Wireless Detector," by Earl H. Swanson  
Elimination of Inductance Disturbances, by F. Kane

### NEW SOLDERING TOOL

A NUMBER of miniature, quick-heating "reach-around-corner" soldering irons have appeared in recent years, but one of the most unusual and useful is the Pres-to-Heat Soldering Tool manufactured by Housung Foundation, Inc., Deep River, Conn. Its principle of operation is similar to that of a resistance welder.

As the photograph indicates, the assembly is in two parts. The power unit contains a transformer which reduces the a.c. line voltage to a low value and raises the current accordingly. The tool itself is a plier-like affair, the jaws of which are made of a special quick-cooling carbon. An actuating lever on the side of the hand-fitting composition case closes the jaws with slight pressure and with greater pressure closes a switch which connects the carbon jaws across the high-current supply. Any conductor through which the current from the carbons passes is heated almost instantly.

Operation of the tool is quick, clean, and easy, as proved by its use over a weekend in constructing an amplifier. The parts to be soldered are secured mechanically (though this is not actually necessary, due to the plier action of the tool). The carbon jaws are placed around the work and the actuating lever squeezed just enough to hold every thing in place. A little more squeeze clicks the switch, and the work starts heating.

The solder should be applied quickly and the switch clicked on and off to prevent overheating. Three or four practice tries perfect the technique, and

### WHERE TO BUY IT . . .

## WHOLESALE RADIO

of Baltimore

### Completely Wired! PHILMORE 16" Television Chassis

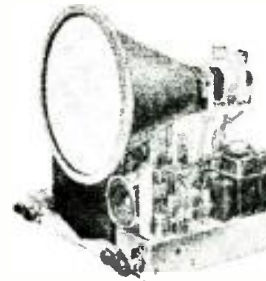

with  
**VOLTAGE  
DOUBLER  
PACK**  
4 MC  
BAND WIDTH  
AUTOMATIC  
GAIN  
CONTROL

**\$199.50**

Complete with 16" Bracket (Less picture tube)

This completely assembled chassis has all the outstanding features of the famous 630 and 830 T.S. circuits. Completely factory wired, a signed and tested just plug it in. Order Model CP-20-10.

### Accessories For Philmore 16" TV

16AP4—16" Picture Tube . . . . . \$61.50  
Plastic Ring for 16" Metal Tube, 1 both for Plastic Sleeve for 16" Metal Tube. . . \$4.15

### 16" TELEVISION CABINET

FIG. 111 B7  
630 T.S. Design Chassis  
Mabeaux finish, complete with protective glass

**\$54.50**

### Low Cost, High Quality Instruments New Jackson Tube Tester



**\$49.50**

Includes the famous dynamic testing method, first used by Jackson. Provides tube tests under actual use conditions. Tests over 700 types including TV receiving and sweep tubes. Built in roll chart. Short and noise tests. Compensation push button rotary switch element and voltage selection. Order Jackson Challenger Model 105.

New Jackson TV Oscilloscope, CRO 1 . . . . . \$195  
New Jackson TV FM Sweep Generator TYG-1 . . . \$220

### T.V. ANTENNA MATCHING TRANSFORMER 72—300 OHM



Model  
T-72 **\$2.40**

Matches 72 ohm coaxial cable such as RG-59/U to 300 ohm receivers. Voltage step up 2:1, with a flat response over the TV channels from 52-216 mc. A W-20 solderless cable connector is furnished. Size 2 inches long, 1 inch diameter. Strap provided for grounding and mounting container on receiver chassis. Negligible mismatch when used with 52 ohm coaxial cable and W-100 adapter.

### NEW LOW PRICES ON TV PICTURE TUBES

Type	Price	Type	Price
5TP4 CR Tube	\$59.40	12JP4	\$41.25
7JP4	16.88	12KP4	41.91
PAP4	16.50	12LP4	39.63
10BP4	27.50	15AP4	65.75
10FP4	29.56	20BP4	55.89
			222.75

WRITE DEPT. OR-84 TODAY FOR OUR  
FREE MONTHLY "FYI" BULLETIN  
Phone MULberry 2134

## WHOLESALE RADIO PARTS CO., Inc. 311 W. Baltimore St. BALTIMORE 1, MD.



almost any connection can be made in about 2 seconds.

While the short heating time is an important advantage, two others are at least equally so. First, the work can be heated to exactly the right temperature to make the solder flow like water, giving a joint that is electrically as

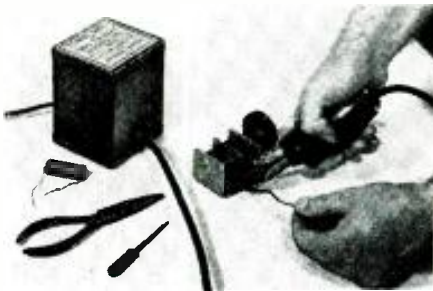

Tool makes perfect solder connection quickly.

solid as possible and using an absolute minimum of solder. Second, because the joint is heated so quickly, no heat to speak of reaches other places to melt capacitor waxes or potting compounds.

**RADAR GAME WARDEN**

Radar spots fishermen operating illegally off the coast of California, General Electric announced last month. The California Fish and Game Commission's newest patrol boat, the *Albacore*, has been equipped with radar. The size of the pip helps identify the type of boat, and the speed at which it moves indicates whether the fishermen are using illegal dragnets.

**ATOMS PLANETS & STARS**  
Astronomical Wall Chart  
(Not A Star M.)  
2nd Edition Revised & Further Developed  
(Size 4 Feet x 2 Feet)  
Nothing Else Like It  
ASTRONOMY VISUALIZED BY GRAPHIC ILLUSTRATIONS  
Illustrated by scaled drawings which show, at a glance, information that would otherwise take hours of reading and study to understand.  
**Dr. Albert Einstein Wrote as follows:**  
"I was extremely pleased to receive your beautiful drawing which gives a vivid representation of our solar system. I have hung it on the wall of my room to look often at it. Sincerely yours."—A. EINSTEIN.  
"The drawing is excellent and informative. You certainly have given an enormous amount of information in a limited space."—DR. FOREST RAY MOULTON.  
"I have never before seen the various features of the solar system and the earth shown so skillfully."—DR. M. M. LEIGHTON.  
"The author has produced for display in school or study, a useful quick reference sheet for the student of elementary astronomy."—JOURNAL OF THE BRITISH INTERPLANETARY SOCIETY, London.  
Note reduced sectional view through the earth, which is only one of many drawings included on this one chart.  
Printed on 70-lb. Sonata Vellum 25% Pure rag ledger paper.  
**Now \$3.50 Each.**  
**James Oliver Hogg, Jr.**  
1840 Burnham Bldg., Chicago 1, Illinois

**NOT SINCE "BEFORE THE WAR" ... ART RADIO TUBES**  
**SUCH TUBE VALUES AS THESE!**

Brought to you by ART RADIO CO.—an old and trusted name. All tubes listed here are available immediately from our huge stock. No waiting. Your order comes in—merchandise goes out—without delay. Stock up now at these terrific prices. All tubes individually boxed, and backed by standard 90-day RMA guarantee.

1L4	6AQ5	6X4	35B5	6AK5	6SD7GT	6W4GT	12SN7GT
1R5	6AT6	12AT6	35C5	6AL5	6SJ7GT	6X5GT	12SQ7GT
1S5	6AU6	12AT7	50B5	6CSGT	6SK7GT	12A6 RCA	12S8GT
1T4	6BA6	12AU6	117Z3	6C6	6SL7GT	12A8GT	25L6GT
1U4	6BA7	12AU7	9001	6J6	6SN7GT	12J5GT RCA	25Z6GT
1U5	6BE6	12AX7	9002	6P5GT	6SQ7GT	12SA7GT	32L7GT
3A4	6BF6	12BA6	9003	6S8GT	6SU7GT	12SJ7GT	35W4
3Q4	6BH6	12BA7	954	6SA7GT	6V6GT	12SK7GT	53
3S4	6BJ6	12BE6	955				
3V4	6C4	12BF6	956				
6AG5	6T8	19T8					

ANY ABOVE TUBE ..... **33c** each

**\$27.95** PER 100 Assorted

Please do not order types not shown on this list.

ANY ABOVE TYPE ..... **37c** each

**\$32.50** PER 100 Assorted

Please do not order types not shown on this list.

**CATHODE RAY TUBES**

First Quality—Fully Guaranteed

Type	Size	Your Cost Each	Type	Size	Your Cost Each
7JP4	7"	\$18.95	12LP4	12 1/2"	\$34.95
10BP4	10"	22.95	All-Glass	15" or 16"	54.95



**ALL-CHANNEL TV ANTENNA**

High and low folded dipoles, with reflectors, complete with mast, specially priced **\$5.95**

**TRANSMITTING & SPECIAL PURPOSE TUBES AT SENSATIONAL SAVINGS**

2AP1 CR	3.95	15R	.69	2050	.99
2C44	1.49	717A	.69	2051	.39
3B7 1291	.39	801	.69	8012	3.95
3C30	.39	807	1.09	9001	.49
3D6 1299	.39	954	.39	9002	.49
5CP1	1.95	955	.39	9003	.49
5CP7	1.95	956	.39	KU627	4.95
5FP7	1.95	1625	.39	RK34	.49
5NP1	3.95	1626	.29	VR105	.99
		1629	.39	VR150	.59

HYTRON No. 5516. \$4.95

We also carry a complete line of other famous-brand tubes and standard radio-electronic components. Send for our catalog today.

**TREMENDOUS SPEAKER BUYS!**

3", 4" or 5" PM, less output, Alnico #5, **98c** each  
In cartons of 30, each ..... 86c  
6"x9" Oval PM, Alnico #5, 3.16 oz. magnet, each **\$2.49**  
In cartons of 24, each ..... \$2.29

3" DYNAMIC, 3000-ohm field, each **49c**  
7/4" PM Replacement Auto Speaker, less output, each **\$2.19**

Minimum order is \$10.00. Orders below \$10.00 cannot be accepted at these amazing prices.

Specify SPECIAL OFFER when ordering from this ad.

**ART RADIO CO.**

115 Liberty St., New York 6, N. Y.

Phone: COrtlandt 7-2918

10% deposit with all COD orders. All Prices F.O.B. N. Y. C.

**HOW TO GET THE MOST** from only **BASIC TEST EQUIPMENT**

**Servicing by Signal Substitution**

The Simple, Modern, Dynamic Speed approach to receiver alignment and adjustment problems, FM-AM-TV.

- Nothing complex to learn
- No extra equipment to purchase
- Universal — non-absorbent
- Employs only Basic Test Equipment

**S-S-S tells HOW — in simple, direct language.**

New 9th edition now off the press. 100 pages of valuable information.

Available from all leading radio parts and equipment distributors or directly from factory at only 40c per copy.

PRECISION APPARATUS COMPANY, Inc. • 92-27 Horace Harding Blvd., Elmhurst 4, N. Y.

**NEVER AGAIN!**



**BRAND NEW—GENUINE**  
**WESTERN ELECTRIC**  
 DRIVER UNIT with REFLEX PROJECTOR  
**WAY BELOW**  
**19<sup>95</sup>** MANUFACTURER'S COST  
 F.O.B. N.Y.C. 4 for \$75.00  
 Excellent for Industrial purposes—Call Systems—Concessions—Ball Parks—Schools—and P. A. Work.

25% DEPOSIT WITH ORDER. BALANCE C.O.D.  
**76 CORTLANDT ST.**  
 NEW YORK 7, NEW YORK  
 Phone: BEekman 3-9530 or REctor 2-6668

**MANUEL KLEIN**

**Television Class**

A one-night-a-week television class will be opened for members of the Radio Technicians Guild in Boston this September. Students will work in a laboratory supplied with test equipment of all the better manufacturers as well as a variety of TV sets.

**Annual Outing**

The Radio Technicians Guild chapter of Lawrence, Massachusetts, held their annual outing at Angle Pond, New Hampshire, June 5. Fifty families were in attendance at the lake. Music was supplied by the sound truck of Jim Mulligan's Radio Laboratory.

**Service Business Saved**

H. H. Hirsch, Dallas radio dealer and service technician, lost all his test equipment and most of his stock in a



Photo Courtesy Dallas Daily Times Herald

flash flood June 13. Fellow members of the Dallas Radio Sales and Service Association immediately acted to save him from ruin. They contributed more than \$800 worth of radio parts and agreed to lend him enough equipment to get started again. In the photo above, the Association's vice-president E. Pflughaupt and secretary, T. P. Robinson are presenting to Mr. Hirsch some of the new equipment collected by the membership.

**New Camden Association**

The Allied Television Association was formed late in June, and elected Ken Holmes president. About 150 technicians were at the organization meeting.

**Westchester Group Forms**

Radio service technicians located in Westchester County, N. Y., formed a new association at a meeting on June 17. Officers elected were Harry Wiegand, president, Thomas M. Olsen, vice-president, Niles Michaelsen, treasurer, and Louis R. Erler, secretary. The second meeting of the group was held on July 12 in Mt. Vernon, N. Y., at which time the name *Independent Radio and Television Technicians of Westchester County* was chosen.

RADIO-ELECTRONICS for

**M-SCOPE GEIGER COUNTER**

- Rate Meter
- Weight 5 Pounds
- Beta-Gama Shield
- Ultra Sensitive
- Flash Indicator
- Headphones
- Low Batt. Cost
- Accurate

PRICES \$97.50 Up  
 TIME PAYMENT PLAN  
 16 Page FREE LITERATURE  
 Upon Request

**FISHER RESEARCH LABORATORY, INC.**  
 1961-63-65 University Ave. PALO ALTO, CALIF.

**GOVERNMENT SURPLUS!**  
**WORLD'S LOWEST PRICE**

**PHOTO FLASH EQUIPMENT**



COMES COMPLETE WITH 4 EDGERTON FLASH TUBES & REFLECTORS

EASY TO CONVERT INTO A 2-WAY PHOTO FLASH UNIT OPERATES ON 110V. AC & 12V. BATTERY

Brand new at a fraction of original cost. Contains finest component parts available. All necessary parts and complete instructions included. After conversion, works on 110V AC or 12V battery by a flick of a switch.

**\$68.** COMPLETE

Immediate delivery on all mail orders  
 CINEC, INC., 165 W. 46th St., N. Y. 19, N. Y., Dept. RES

**Start Full or Spare Time Business at Home**



**METALIZE BABY SHOES for BIG STEADY PROFITS**

No waiting. Cash can start coming in very first day. Money making WARNER SUCCESS PLAN shows every step. Learn quickly, easily without previous training or experience. Plan backed by old established company. Your home is your headquarters. This is too good to pass up since facts cost nothing — now or ever. Don't wait. Send name and address on postcard today to Ray Brandell, Mgr. WARNER ELECTRIC CO., 1512 Jarvis Avenue, Dept. 229, Chicago 26, Illinois

**FREE OFFER of COMPLETE Money Making Success Plan**

We show you how to start—how to get orders rolling in—how to do the work; how to pyramid your profits. Send No Money Just your name and address on Postcard.



**HICKOK New Mobile Radio MICROVOLT GENERATOR**  
 Accuracy to .005%

THE HICKOK ELECTRICAL INSTRUMENT CO.  
 10531 DUPONT AVE. CLEVELAND 8, OHIO

SEE YOUR JOBBER OR WRITE FOR COMPLETE INFORMATION TODAY



John Reinartz has been appointed by EITEL-McCULLOUGH, INC., of San Bruno, Calif., to assist in directing the application of Eimac tubes for amateur use.

Reinartz, long known for his technical contributions to radio, was formerly with RCA where he acted as technical expert for RCA's ham program. In 1908 he put up his first transmitter on his father's farm in New England, using a half-inch spark coil and a 60-foot antenna between two trees. Since then, his CQ. first from QP and 1XAM and now from W3RB, was a familiar call over a quarter of a century of hamming. Among his accomplishments are the design of the Reinartz tuner, his published work on *Reflection Theory of Short Waves*, and his communications work with the Byrd Arctic Expedition in 1925 where he kept the expedition in daily communication with civilization. He also has to his credit over 20 patents covering circuitry.



C. O. Wanvig, president of GLOBE-UNION, INC., Milwaukee, Wisconsin, has been elected chairman of the board, and Wyeth Allen, executive vice-president for the past year and Globe management consultant for the past 20 years was elected president to succeed him.



Robert N. Baggs has been appointed sales manager of consumer products service for the RCA SERVICE Co., INC., it was announced by J. A. Milling, vice-president in charge of the consumer products service division at Camden, N. J.

Mr. Baggs, who is widely known among radio dealers and servicemen through his 18 years of activity in the trade, will supervise sales, sales promotion, and customer and trade relations on radio, phonograph, and television service. He will direct sales of RCA consumer products service.

W. H. Lamb, formerly general manufacturing manager for television tubes, has been appointed general manager of a new division of SYLVANIA ELECTRIC PRODUCTS, INC., which is to specialize in the design, engineering, and production of viewing tubes for television receivers. This was announced last month by H. Ward Zimmer, who is vice president in charge of operations.



## 4 KITS AT SENSATIONALLY LOW PRICES!



The New Model KT-40

### VACUUM TUBE VOLTMETER

**FEATURES:** \* Uses 4 1/2" — 2% accurate D'Arsonval type Meter with high torque movement and Alnico V slug. \* Meter guaranteed against burn-out on ALL electronic ranges. Meter will not be damaged even when improperly switched to higher range. \* Stabilized degenerative circuit results in linear D.C. scale. Isolating test-prod for all D.C. Voltage ranges. Megohm input resistance on all D.C. ranges. Ohmmeter accurately measures from 1/10th ohm to 1 billion ohms.

**SPECIFICATIONS:** D.C. VOLTS: (At 11 megohms input resistance) 0 to 3/30 150 750 1,500 Volts. A.C. VOLTS: (At 1,000 ohms per Volt) 0 to 3/30 150 750 1,500 Volts. **RESISTANCE:** 0 to 1,000 10,000/100,000 ohms. 0 to 10 meg-ohms/1,000 megohms. **D.B.:** Based on 0 Db equals .006 watts (6 milliwatts) into a 500 ohm line. — 24 db to + 4 db + 10 db to + 38 db — 4 db to + 24 db — 30 db to + 58 db Model KT 40 Kit comes complete with all parts including test leads, V.T.V.M. Prod. circuit, operating instructions etc.. Net only

**\$19.90**

The New Model 247

### TUBE TESTER

Check octals, loctals, bantam Jr. peanuts, television miniatures, magic eye, hearing aids, thyratrons, the new type H.F. miniatures, etc.

**FEATURES:** \* Newly designed element selector switch reduces the possibility of obsolescence to an absolute minimum. \* When checking Diode, Triode and Pentode sections of multi-purpose tubes, sections can be tested individually. A special isolating circuit allows each section to be tested as if it were in a separate envelope. The Model 247 provides a super-sensitive method of checking for shorts and leakages up to 5 Megohms between any and all of the terminals. One of the most important improvements, we believe, is the fact that the 4-position fast action snap switches are all numbered in exact accordance with the standard R.M.A. numbering system. Thus, if the element terminating in pin No. 7 of a tube is under test, button No. 7 is used for that test.

Model 247 Kit comes with all parts, new speed-read chart, handsome hand-rubbed oak cabinet sloped for bench use. A slip-on hinged cover is included for outside use.



**\$21.90**

NOTHING ELSE TO BUY: ONLY

The Model CA-12

### SIGNAL TRACER FOR FM-AM TELEVISION

Increasing production of F.M. and Television Receivers means MORE COMPLEX Receivers. Now more than ever this time-saving method of quickly and easily LOCALIZING the exact cause of trouble becomes the "must" Method.

**The only Signal Tracer in the Low Price Range Including BOTH METER AND SPEAKER!!**



**FEATURES:** \* Comparative intensity of the signal is read directly on the meter—quality of the signal is heard in the speaker. \* Simple to operate—only one connecting cable—no tuning controls. \* Highly sensitive—uses an improved vacuum-tube voltmeter circuit. \* Tube and resistor capacity network are built into the detector probe. \* Built-in high gain amplifier—Alnico V speaker. \* Completely portable—weighs 8 pounds—measures 5 1/2" x 6 1/2" x 9". **MODEL CA-12 Kit includes ALL PARTS, circuit diagram and detailed operating data for the completed instrument.**

**\$21.95**

NOTHING ELSE TO BUY

The New General

### V. H. F. PROBE

Uses a Silicon V.H.F. Diode which together with a resistance capacity network provides a frequency range up to:

**1000 MEGACYCLES**

This probe is designed to operate in conjunction with any standard V.O.M. (with a sensitivity of 5,000 ohms per volt or better) any Electronic V.O.M. or V.T.V.M. Probe Kit includes all parts, instructions, etc.

NOTHING ELSE TO BUY: ONLY



**\$3.45**

20% DEPOSIT REQUIRED ON ALL C.O.D. ORDERS

**GENERAL ELECTRONIC DISTRIBUTING CO., INC.**

98 Park Place

Dept. RC-9

New York 7, N. Y.

**SEPTEMBER SPECIALS:**



**MP-22 MAST BASE** Mounting with spring action and mounting bracket insulated at top to receive MS-53 Mast Section listed below. Mast Base MP-22 only \$2.95

**MAST SECTIONS**—For above MP-22 Base, tubular steel, copper coated, painted in 3 foot sections. Bottom section MS-53 can be used to make any length. MS-52-51-50-B for taper. Screw-in type. Any section—Price 50c Ea.

**TELESCOPING STEEL ANTENNA** Three sections 24" long. Telescoped 30". Size: 3/4" to 1 1/4". Price \$1.50

**COMMAND TRANS. AND RECEIVER TRANSFORMERS—110 V.A.C. 60 CYCLE INPUT**

Output: 600-0-600 V.A.C. at 250 MA. 12 V.A.C. at 3 amps; 12 V.A.C. at 3 amps, & 5 V.A.C. at 3 amps. = REH-108 \$6.90  
 Output: 250-0-250 V.A.C. at 60 MA. 24 V.A.C. at 8 amps; 6.3 V.A.C. at 8 amps. = REH-109 \$3.00

**MOTORS**

6 or 12 Volt AC-DC Heavy Duty reversible Motor with 5/16" x 7/16" shaft. Price: New \$2.95  
 6 Volt AC-DC Motor—Ideal for auto fans, models, etc. Shaft 1/4" x 7/16". Used—Tested \$1.50  
 Model Motor—12 Volt AC-DC 1/2" double end shaft Motor. Size: 2 1/2" L. x 2 1/2" W. x 1 1/2" H. Price \$1.50  
 110 Volt 60 cycle. Ball Bearing Motor, approx. 3500 RPM. 1 25 H.P. Shaft: 3/16" x 5/8". Motor size: 6 1/2" L. x 4 1/2" H. Converted type. Price \$2.95  
 Hand Tool Motor—12 Volt AC-DC—5000 RPM. 3/8" L. x 1 1/4" Dia. with splined shaft 3/4" D. x 1/2" L. Price \$2.95  
 BLOWER—110 Volt 60 cycle. 3" intake, 2" outlet. Approx. 100 cu. ft. this Motor size: 3 1/2" x 3"—1750 RPM. Price, New, \$6.95. Price—Motor only \$3.95

**MISCELLANEOUS:**

Coaxial Cable—125 OHM Cotton covered—50 Ft. \$1.00  
 Coaxial Cable—75 OHM Rubber covered—8 Ft. .50  
 Cable—1 Cond. Rub. covered—shielded—50 Ft. 2.00  
 Wire—2 Cond. Rub. covered #11 stranded—20 Ft. 1.00  
**FL-8 FILTER 12000 CPS**  
 FT-17 or 25 for 10" 223. Price, New 4.50  
 Cable for 10" 223 w PL 50 each end 1.75  
 Cable for 10" 375 w PL-61 each end 1.75  
 Cable for 10" 375 w PL-61, 65F10, or 65F13 2.05  
 LP 21A Loop—Price, Used 1.00  
 Plug for LP-21 Loop—PL-112 or PL-108 1.00  
 PL-395 Cond for LP-21 Loop 1.50

Address Dept. RE • Prices—F.O.B., Lima, Ohio • 25% Deposit on C.O.D.'s • Minimum Order \$2.00

**FAIR RADIO SALES 132 SOUTH MAIN ST. LIMA, OHIO**

**New!** highest efficiency of any known D.C. power supply in the 3 to 9 volt range

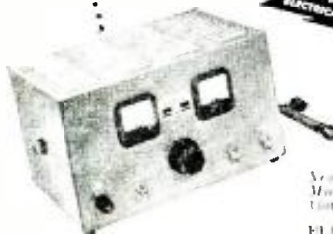

Look at the Features!

- ✓ New heavy duty selenium rectifiers.
- ✓ Eight power tap adjustments.
- ✓ 1 to 20 amperes at 6 volts continuous duty.
- ✓ Less than 3% A.C. ripple or hum.
- ✓ Dropped volt and ammeters (no wiggling) Voltmeter 3% accuracy.
- ✓ Heavy duty tap switch.
- ✓ The RIGHT price.

Never before has there been a power supply like the ELECTRO Model "B". Radically new in design—trouble free in operation—most efficient direct current source of power known.

ELECTRO PRODUCTS Model "B" is the only D.C. Power Unit using conduction cooling shows instant readings. Has exclusive new heavy duty selenium rectifiers—step power switch—transformer—thoke and condenser.

The 20 ampere 6 volt continuous rating provides more than enough power to operate any receiver. Peak instantaneous current rating of 5 amperes (20 to 50 cycle 115 v power source), permits operation of two receivers with push button demands.

Use it for testing auto radios, faulty vibrators, push button solenoids, over and under voltage operating conditions on any size radio, and many other applications.

WRITE TODAY FOR COMPLETE DETAILS

**ELECTRO PRODUCTS LABORATORIES, INC.**

Pioneer Manufacturers of Battery Eliminators

549 W. Randolph St.

Chicago 6, Ill.

**FT-237 MOUNTING**—For 6C-604 and 603's, and for 6C-84 and 663's. Prices: Used—\$7.00; New \$9.95  
**GN-45 GENERATOR** only. Used \$5.00  
**LEG AND SEAT ASSY.** F/Hand Gen. 2.75  
**CRANKS F/Hand Generators, ea.** .75

**SELSYN TRANSMITTER & INDICATOR SYSTEM**

Ideal as radio beam position indicator for Ham, Television, or Commercial use. Complete with 5 inch 1-82 Indicator, Antisyn Trans., 12 Volt 60 cycle Transformer, and wiring instructions. Price \$7.95  
**NEW \$9.95—Used \$7.00**  
 PL-118 PL-119 PL-182



**DYNAMOTOR** Use your electric shaver in your car! Dynamotor will supply 110 Volt 100 MA from 6 VDC and will operate most types of AC/DC shavers. Normal operation 12 VDC input; 220 Volt 100 MA output \$1.95

**DYNAMOTORS:**

INPUT:	OUTPUT:	STOCK No.:	PRICE:
9 V. DC	450 V. 60 MA	D 9150	\$3.95
12 V. DC	220 V. 100 MA	D 402	3.95
12 V. DC	410 V. 200 MA	D 401	7.95
28 V. DC	F/SOR 522	PE 91	7.95
12/24 V. DC	F No. 10/MARK II	PS #3	9.50
12/24 V. DC	F/10-645	PE 101	2.95
12/24 V. DC	500 V. 50 MA	D 0505	2.95
28 V. DC	F Comm. Re-		
	ceivers	DM 32	1.95
11 V. DC	230 V. 100 MA	DM 20	3.95
12/24 V. DC	410 V. 200 MA		
	and 220 V. 100	D 101	9.95
	MA		
28 V. DC	400 Cycle Inverter	MG 119P	14.95
		(Reconditioned)	

**211GI SELSYN MOTORS—WITH CAPS:** Can be used as position indicator for antennas; 110 Volt 60 cycle, with instructions. Normally operates from 57.5 Volts 400 cycle. Price per pair \$3.00; Price—Caps only, ea. 50c

**SELSYN #C-78248—115 Volt AC 60 cycle. Size V 3 1/2" x 5 1/2".** Can be used to turn small antennas or for position indicator systems. Price per Pair \$3.95

**TRANSFORMERS—110 Volt 60 Cycle Primaries:**

Sec. 24 Volt 2 amp.	\$2.25
Sec. 14-11 or 28 Volt 7 1/2 or 15 amp.	4.95
Sec. 12 Volt 1 amp.	1.50
Sec. 24 Volt 1 amp.	1.95
Sec. 24 Volt 1.5 amp.	1.95
Sec. 28 V A 42, 2.5 amp.	1.50
250 VCT—60 MA 6.3 V, 5 amp., 5 V, 3 amp.	2.45
250 VCT—90 MA 6.3 V, 4 amp., 5 V, 3 amp.	2.05
250 VCT—200 MA 6.3 V, 6 amp., 5 V, 3 amp.	4.75

250 VCT—200 MA 6.3 V, 6 amp., 5 V, 3 amp. \$4.75

**CROSLEY TV MODEL 9-408**

If the complaint is no raster or image on the C-R tube, use a high-range meter with high-voltage test leads to check the high-voltage supply. If the voltage is approximately 1,500, replace the 500-µf, 10-kv filter capacitor.

JAMES MOUDRY,  
Cicero, Ill.

**MANTOLA 7156 AND 7160-17**

When these and similar models work perfectly on phono and have a loud hum on radio, look for a broken ground lead on the socket of the 12BA6 i.f. amplifier. This ground was originally under one of the rivets holding the 12BA6 socket to the chassis.

FLOYD A. ROBERTS,  
Kearney, Nebraska

**A TIP ON SOLDERING IRONS**

Soldering-iron tips will last almost indefinitely without corroding or pitting if coated with a layer of silver solder. Your local plumber will do the job for a nominal fee, but you can do it yourself by heating the tip in the flame of a gas burner or blowtorch and then applying silver solder. The coating will not melt or corrode in ordinary use because its melting point is much higher than that of standard solders used for ordinary electrical soldering and metal work.

ALFRED HANZL,  
Wallington, N. J.

**PHILCO 46-1203**

If touching any part of the record changer causes a loud hum when the phono switch is on, remove the .05-µf, 200-volt capacitor connected between the low side of the pickup and the frame of the changer. (This capacitor is on a tie strip near the changer.) Then connect a 0.1-µf, 600-volt capacitor between the frame of the changer and the chassis of the set. This capacitor may be mounted on the tie strip mentioned previously.

D. A. WEILER,  
Metairie, La.

**PHILCO TV RECEIVERS**

When the complaint is a weak or unstable picture on one or more channels, check the small springs which make contact with the coils in the turret tuner. These springs break easily when adjusted for heavy tension on the contacts.

LOUIS S. KOVACS,  
Detroit, Mich.

**2 STATION INTERCOM KIT**  
 A must item for offices, schools, churches, etc. A wonderful bargain at the price.  
**COMPLETE KIT—ALL PARTS. TUBES & 2 SPEAKERS** \$9.95 f.o.b. our plant

**Universal/general corp.**  
 365 Canal St., New York 13 WA 5-9642

RADIO-ELECTRONICS for



**CRITICS DISAGREE**

Dear Editor:

I would renew my subscription but I believe your magazine is about 5 years behind times. A deluxe and fancy cover does not change its contents, nor for that matter does its name. All I see is crystal sets and 1, 2, 3, 4 and 5 tube phlooper dooper ultra phoney regenerative sets.

So what? What service man is interested in that? How about the latest things? I get more out of other magazines than I ever hope to get out of yours. How about the latest television set schematics with the components listed and a detailed account of anything new and intricate? How about schematics of hi-frequency scopes that will take television? About wobblers for TV and FM? Will we ever see them in RADIO-ELECTRONICS?

MAX GOODSTERN  
No address

Dear Editor:

I have read the many compliments that your readers have sent to you concerning your magazine, and I would like to join them.

But sir! You are making a grave mistake. You are omitting a department for the beginner and the experimenter. I am sure that we cannot be expected to build your ten-tube FM sets etc., and I am also sure that your more experienced readers will not object to us having a page or two on a one- to two-tube set, as even they had to start from the beginning before they knew much about radio.

WALTER JEFFRIES, JR.  
Durban, South Africa

(So there is the situation. It used to be said that people see what they want to see. In a magazine it appears the opposite must be the case—they apparently see what they don't want!—Editor)

**AVAILABILITY OF SKIATRONS**

Dear Editor:

Thank you for your letter inquiring about the availability of "Skiatron" tubes.

These tubes were employed to a considerable extent during the war for radar purposes, and, as mentioned in my recent article in your magazine,\* under the code name of "Dark Trace Tubes." They are further designated as AP10 tubes (depending on the screen diameter in inches, as 4AP10 or 5AP10) and under that designation may be available on the surplus market.

Note well, however, that these available AP10 tubes were specifically designed for slow, long-delay radar display, and are not suitable for television. Tubes for television are still in the development stage and are not at present available.

(Dr.) A. H. ROSENTHAL,  
Forest Hills, N. Y.

\*March 1949, page 36

**DEPEND ON IRC**

**FOR TELEVISION SERVICING**

Television servicing requires replacements of *absolute* dependability. Otherwise, you risk expensive call-backs. Be positive of that dependability in resistors and controls... always buy "IRC"! Produced by the largest resistor manufacturer in the world, IRC parts are standard equipment in the finest television sets.

New, Advanced Type BT Resistors are IRC engineered to meet the rigorous requirements of television. They surpass Army-Navy Specification Jan-R-11. Small, fully insulated, and cool operating, Advanced BT's are supplied in 1/2, 1 and 2 watt sizes.

Every requirement of television servicing has been considered in the design of IRC's new, compact 15/16" volume controls. Revolutionary Interchangeable Fixed Shaft feature means faster and better servicing... resilient retaining ring cushions the turn; your customers can feel the difference.

New IRC PRECISTORS are ideal as low cost replacements for wire wound precisions and strings of insulated resistors. These deposited carbon units combine accuracy, stability and economy. Guaranteed accuracy 1%, in 2 sizes and a wide range of values.

For vertical or horizontal centering, IRC Type W Wire Wound Controls are furnished with a center tap. Tight, uniform windings insure accurate focusing.

International Resistance Co., 401 N. Broad St., Phila. 8, Pa. In Canada: International Resistance Co., Ltd., Toronto, Licensee.



**ADVANCED TYPE BT'S**  
BT means Better Television!  
Tiny 1/2, 1 and 2 watt resistors are JAN approved.



**NEW INTERCHANGEABLE FIXED SHAFT CONTROLS**  
quiet operating, compact 15/16" design.



**CLOSE TOLERANCE PRECISTORS**  
guaranteed accuracy 1%.



**CENTERING CONTROLS**  
for accurate horizontal or vertical focusing IRC Type W Control

**INTERNATIONAL RESISTANCE CO.**

Wherever the Circuit Says





**HICKOK**

*Complete*

**TELEVISION GENERATOR**

More in use today than all other TV generators combined

*World Famous*

MODEL 610A
THE HICKOK ELECTRICAL INSTRUMENT CO.  
10531 DUPONT AVE. • CLEVELAND 8, OHIO

SEE YOUR JOBBER OR WRITE FOR COMPLETE INFORMATION TODAY

# EMC MODEL 102 POCKET VOLUMETER\*



## A REMARKABLE "POCKET-TYPE" TESTING INSTRUMENT

- LEGIBLE** 3" SQUARE METER (1,000 ohms per volt) for easy, rapid and accurate reading.
- HANDY** Size only 3/4"x6 1/4"x2" deep.
- LIGHT** Weighs only 1 lb. 5 oz.
- ACCURATE** 1 Mil D'Arsonval type meter 2% accurate.
- STURDY** Ruggedly constructed, round cornered, molded bakelite case.
- VERSATILE** 3 AC CURRENT RANGES: 0.30/150/600 ma.  
4 DC Current Ranges: 0.6/30/120 ma: 0.1.2 amps. 5 AC Voltage Ranges: 0.12/120/600/1200/3000 volts. 5 DC Voltage Ranges: 0.6/-60/300/600/3000 volts. 2 Resistance Ranges: 0-1000 ohms, 0-1 megohms.
- SIMPLE** Same zero adjustment for both resistance ranges.

**LOW COST** **ONLY \$13.90**  
 EMC (Reg. Trade Mark for Volt-Ohm-Milliammeter)  
 At your favorite supplier or write to Dept. R-9  
 for free catalog of EMC Test Equipment.  
**ELECTRONIC MEASUREMENTS CORP.**  
 423 BROOME ST. New York 13, N. Y.

## PHILCO MALIGNED

Dear Editor:

This is to protest the letter from Mr. J. E. Epperson, printed in your June issue.

May I point out that, as far as I know, the Philco Corporation is the only one that furnishes you free of charge circuit diagrams of all their sets, including all parts numbers; and that it will also give you free television instruction with very little expense on your part.

I have found Philco parts more easily obtained than those for many other sets. As for the troubles he found—I have found about the same faults, with slight variations, in sets of more than one different make.

If Mr. Epperson can name any other company that gives the service technician more information than does Philco, please let me know, as I would like to take advantage of such information to help me maintain service on their sets.

LLOYD O. WALTER,  
Dillonville, Ohio

## EVERY SERVICEMAN CAN afford SUPERIOR TEST EQUIPMENT THE NEW MODEL TV-10 TUBE TESTER



- Tests all tubes including 4, 5, 6, 7, Octal, Lock-in, Preanu, Bentam, Near-in-a-d, Tnyratron, Miniatures, Sub-Miniatures, Novols, etc.
- Uses the new self-cleaning Lever Action Switches for individual element testing. Because all elements are numbered according to pin-number in the RMA base numbering system, the user can instantly identify which element is under test. Tubes having tapered filaments and tubes with filaments terminating in more than one pin are truly tested with the Model TV-10 as any of the pins may be placed in the neutral position when necessary.
- The Model TV-10 does not use any combination type sockets. Instead individual sockets are used for each type of tube. Thus it is impossible to damage a tube by inserting it in the wrong socket.
- Free-moving built-in roll chart provides complete data for all tubes.
- Newly designed Line Voltage Control compensates for variation of any line voltage between 105 Volts and 130 Volts.

The Model TV-10 operates on 105-130 Volt 60 cycles A.C. Comes housed in a beautiful hand-rubbed oak cabinet complete with portable cover. **\$39.50 NET**

MFD. BY

We manufacture a complete line of radio test equipment. Write Dept. RC-9 for FREE catalog today!



**SUPERIOR INSTRUMENTS CO.**  
227 Fulton St., New York 7, N. Y.

at your regular jobber



Assembled for your convenience  
**Facts, standards  
 practices, data**  
 for the whole field  
 of radio engineering

## Radio Engineering Library

Radio specialists of the McGraw-Hill publications selected the books for this library as those giving the most complete, dependable coverage of facts needed by engineers whose special fields are rounded up in radio fundamentals. They cover circuit phenomena, tube theory, networks, measurements, and other subjects... give specialized treatment of all fields of practical design and application.

### Library includes:

1. Fundamentals of Vacuum Tubes—Eastman
  2. Radio Engineering—Terman
  3. Communication Engineering—Everitt
  4. High-Frequency Measurements—Hund
  5. Radio Engineering Handbook—Henney
- 3559 pages!  
2358 illustrations!

- ★ Special Low Price
- ★ Bought singly, the five volumes would cost \$3. Under this offer you save \$2.50.
- ★ Pay in easy installments

**FREE 10 Day Trial**

McGraw-Hill Book Co., 330 W. 42nd St., N.Y.C. 18  
 Send me Radio Engineering Library, 5 vols., for 10 days' examination on approval. In 10 days I will send \$2.50, plus few cents postage, and \$5.00 monthly till \$27.50 is paid. (I return books postpaid.)

Name \_\_\_\_\_  
 Address \_\_\_\_\_  
 City \_\_\_\_\_ Zone \_\_\_\_\_ State \_\_\_\_\_  
 Company \_\_\_\_\_  
 Position \_\_\_\_\_ RC-9-49

RADIO-ELECTRONICS for

**\$10,000 REWARD**  
 Earn the maximum bonus by locating Radio-Actives Ors with a  
**P.R.I. GEIGER COUNTER**  
 Weighs only 2 lbs. Priced from \$19.50 complete. The most sensitive portable Geiger Counters made.  
**PRECISION RADIATION INSTRUMENTS, INC.**  
 1101-L N. Paulina St. Chicago 22, Ill.  
 Dealer Inquiries Invited

**\$3.00 FOR CARTOON IDEAS**  
 RADIO-ELECTRONICS prints radio cartoons every month. Readers are invited to contribute humorous radio ideas which can be used in cartoon form. It is not necessary that you draw a sketch, unless you wish.



**VIBRATION AND SOUND** (second edition), by Philip M. Morse. Published by McGraw-Hill Book Co., Inc., New York. 6 1/4 x 9 1/4 inches, 468 pages. Price \$5.50.

The second edition of this book on the theory of vibrations and sound includes more detail on radiation problems than did the first edition (published in 1936) and introduces the subject of transient phenomena and the technique of operational calculus. The book is a thorough mathematical exposition of its subject on the level of basic physics—it is not a practical treatise. The author taught the introductory course in this subject at MIT for several years; he is now director of Brookhaven National Laboratory at Upton, N. Y.

**TV-FM ANTENNA INSTALLATION**, by Ira Kamen and Lewis Winner. Published by Bryan Davis Publishing Co., Inc. 6 x 9 inches, 105 pages, plus 17-page advertising section. Price \$2.00.

The reader expects authoritative and complete coverage of the subject in a book by these two authors. Mr. Kamen has had wide experience with antenna installations in New York City; Mr. Winner is an editor of radio service magazines of long standing. It is therefore no surprise that many points neglected in other works are carefully dealt with in this one.

The mechanical aspects of antenna installation are especially well covered, one chapter being devoted to installation tools alone. Other chapters handle special coverage problems, high-fre-

quency installations, fringe-area antennas, and master or apartment-house systems.

Television interference is given a chapter, and another one is devoted to special installation tricks. FM antennas, business practices, and safety precautions are also discussed, and the book closes with a very complete index.

**INVENTION AND INNOVATION IN THE RADIO INDUSTRY**, by W. Rupert MacLaurin with the technical assistance of R. Joyce Harman. Foreword by Karl T. Compton. Published by The Macmillan Company, New York. 6 x 8 1/2 inches. 304 pages. Price \$6.00.

The work of inventors and innovators (persons or firms who put new ideas—not necessarily their own—to work) is traced in this book from the pre-radio scientists such as Faraday to the research scientists and firms of the present day.

Though written primarily as a study of the impact of the work of inventors, entrepreneurs, business conditions, law and other factors on the growth and development of invention and innovation in the industry, the book is one of the best short histories of radio written to this date, and will be read as such by many who are interested chiefly in the events rather than the underlying implications, and who will find the facts here marshalled in convenient and easily-read form.

The appendix includes a two-page explanation of r.f. and modulation and a detailed statistical breakdown of past radio patent litigation.

## MAKES AUTO RADIO REPAIR TWICE AS EASY!

Here—prepared by an auto radio expert of 20 years standing—is everything you need to know to install, service and repair all types of auto radios faster—easier—more profitably. Covering every type of auto radio from the mid-1930's, this compact book gives you complete installation, troubleshooting and repair procedures plus this on how to set up shop and get business.



## SERVICING THE MODERN CAR RADIO

by A. L. Hurlbut

2nd Edition. 702 pages. 8 1/2 x 11. 222 illus. and over 500 car radio diagrams. Price \$7.50.

You'll really know how to repair auto radios profitably after reading this great book! From basic theory through step-by-step servicing methods, every detail of the work is explained in a way you can easily understand. Differences between car and ordinary radios; antennas; antenna input circuits; power supply; circuit features; automotive electrical systems; installations; loudspeakers; interference; vibrator maintenance; alignment; push-button tuning and other related subjects are covered completely.

### OVER 500 CIRCUIT DIAGRAMS

Of particular importance, **SERVICING THE MODERN CAR RADIO** contains over 500 circuit diagrams giving circuit details of specific car radio types you are most likely to be called upon to repair. This feature alone can save you many times the cost of the book. Use coupon today for examination.

### 5-DAY MONEY-BACK GUARANTEE

Dept. RE-99, MURRAY HILL BOOKS, Inc., 232 Madison Ave., New York 16, N.Y.

Send me Hurlbut's **SERVICING THE MODERN CAR RADIO** book for which I enclose \$7.50 (US\$8.00 outside U.S.A.) or, send C.O.D. for this amount plus postage. (No foreign C.O.D.'s.) If book is not satisfactory it is understood I may return it in 5 days and you guarantee to refund my \$7.50.

Name.....

Street.....

City & Zone.....

State.....

### HEAT GUN

Streamlined pistol grip heat gun in standard housing, that delivers a powerful 20 cubic ft. per minute blast of hot air at 100° Fahrenheit. Ordinary houses have small fans, but this has a lifetime-lubricated AC-DC motor of the unique vacuum cleaner type, that produces a hurricane of either hot or cold air. Perfect for blowing out dirt or dust, drying out heating systems, warming up radiators, driving paint, thawing out gutters, etc. Warning—Keep this away from your wife, or she will be using it to dry her hair because it will do it in half the time of her ordinary hair dryer, to say nothing of her using it to dry stockings or clothing, or dirt in the refrigerator instantly. Only \$12.95. Satisfaction guaranteed in money refunded if returned pre-paid within 5 days.



### COMPRESSED AIR

INSTANTLY ANYWHERE

Portable Air Compressor and storage tank. Ruggedly built of best materials, using lifetime-lubricated ball-bearing on connecting rod and oil impregnated main bearing on shaft. Final design forever eliminates valve trouble, the most common fault in all compressors. **PATENTED** unique air intake system increases efficiency tremendously over other compressors so that air output is much greater than that from larger compressors powered by heavier motors. Will deliver approximately 3500 cu. inches of air per minute at maintained pressure of 30 lbs., or will inflate a 90 lb. truck tire in less than one minute. Comes complete with 100 lb. gauge, although finger-tip adjustment allows setting of output pressure at any value, which will automatically be maintained. Works from any 1/4 H.P. motor. Useful for spraying paints or lacquers, disinfectants, insecticides, anaesthetics, or heating with natural gas, kerosene, etc. Price \$14.50. Postage prepaid anywhere in the U. S. Efficient, completely portable with 12 ft. of 100 lb. tested hose available for only \$7.75 with pint container also prepaid, 25% required on all C.O.D. orders.



### BUFRAD CAR RADIO ANTENNAS

All of our car radio antennas are made of triple plated Admiralty brass. Tuning complete with low loss shielded antenna leads and high quality fittings.

**SIDE COWL BB-1**, 8 sections extend to 66". Your price—\$1.75; in lots of 12—\$1.50 ea.

**SKYSCRAPER** BB-2 has 4 heavy duty sections that extend 98". This super-aerial must be seen to be fully appreciated. Your price—single units—\$2.50; in lots of 12—\$2.25 ea.

**TILT ANGLE** BB-3, may be adjusted to all body contours. 3 sections extend to 66". Single unit price—\$1.75; 12 lot price—\$1.50 ea.

**VERSATILE** BB-4, single hole fender or roof mounting may be adjusted to run with all body contours. 4 sections extend to 56". Single unit price—\$3.00; 12 lot price—\$2.75 ea.

**THE MONARCH** BB-5, single hole, top cowl mounting. 3 sections extend to 54". Single unit price—\$2.00; 12 lot price—\$1.75 ea.

### SUPER SPECIAL

**FAIRCHILD** bombproof POWER UNITS. Our quantity of these is too limited to justify the space required by a photo, but each unit is brand new, contains 9 tubes which alone have a total value of \$15.00; 8 electric motors or generators, 6 of which are of the permanent magnet field type; relays; and 30 valuable precision resistors plus a multitude of the ordinary kind. In addition to many condensers and potentiometers. All for only \$14.95.

### SCR-274N COMMAND SETS

(Made by Western Electric for U. S. Gov't) THE GREATEST RADIO VALUE IN HISTORY!!

A mountain of valuable equipment that includes not 1 but 3 of the hottest superhet Communications Receivers, each of which has a tuned R.F. stage, 3 gang condenser, crystal, and 6 working tubes not counting rectifiers. Also included are 2 Tuning Control Boxes; 1 Antenna Tuning Box with R.F. meter to measure power fed into antenna; four 28V Dynamos (alternation of set to 110V operation is quick and simple); two 10 Watt Transmitters including crystals; and Pre-Amplifier and Modulator so that transmitters can be used for voice as well as for code. 29 Tubes supplied in all. In guaranteed electrical condition. Transmitters and Receivers instantly removable from mounting racks which hold them in positions in aircraft use, so that they can be split up and used separately at different locations just like any other sets. Only a limited quantity available, so get your order in fast. A super value at \$59.95.

### 1000 CYCLE AUDIO FILTERS

**Navy PD52010-1** low pass audio filters as mentioned in the "Peaked Audio" article in June CQ, and designated by the above number, are the exact electrical and physical equivalent of commercial audio filter units selling for \$35.00 wholesale. They are infinitely better than the surplus "Radio Range Filters" being sold for reducing QRM, and at 2 KC off resonance for example, a 2 section filter using PD52010-1 is capable of twice the selectivity available through the use of the QR-er. (the BC453 section of the 274N which has provided the amateur's previous highest standard of interference elimination). **EXTRA SPECIAL — NAVY PD52010-1 with diagram — \$5.00.**

### DELUXE SUPERHET A.C.-D.C. RADIO KIT

Extra big quality standard production line radio kit form with complete instructions. Features 2 iron core I.F. transformers, a 2 gang condenser, and polyethylene insulated silver-sprayed wound 12BE6, 6BE6 & 6BW6. Receives broadcast band from 550 to 1700 KC. Kit form \$8.75 or 2 for \$17.00. Assembled, wired & tested \$12.95 or 2 for \$25.00.

### MICROPHONES

Super Special—highest quality all chrome bullet shaped CRYSTAL MIKE of top-flight nationally known brand—\$5.95. Bullet DYNAMIC MIKE—\$7.85. MIKE J—60

### "SO" RADAR SET

"SO" RADAR SET complete with 9 tubes including picture tube. This Plain-Indication Indicator Oscilloscope has a self-contained back designed to run from the 110 V. power supply on LST or PT boats. It provides a 5" diameter picture adjustable at will to an 80, 40, 1 or 2 mile circle with the boat at the center, suggests location of land, other ships, or obstruction, so that navigation can be carried out in pitch darkness or densest fog with as much safety as in brightest sunlight. Your cost \$39.95.

### RT1655 Only \$14.95



11 tube crystal controlled superheterodyne receiver that covers the FM band. The ultra modern circuit uses the latest types of tubes including 7 miniature 6AJ5's. Beautiful chassis and aluminum cabinet. Tubes and diagram included.

**LINE FILTERS**—Each unit contains two 1 Mfd. oil filled condensers and a high inductance 50 amp ratchet in fully shielded case. Suitable heavy current connectors are provided to attach to the input and output connectors at each end of the filter from your input and output wires. A filter with innumerable uses on oil burners, refrigerators, boats, automobiles and wherever noise is to be suppressed or interference abolished. A \$17.00 value for \$1.98.

### SUPER SPECIAL ON: ISOLATION TRANSFORMERS AT \$1.95

Many adjustments on radios and TV sets, especially the AC-D.C. types, require that the chassis be grounded for stability and satisfactory results. Using an isolation transformer this can be done as a routine procedure on every set on the test bench with the hazard of shock and the usual but unwelcome fireworks. Constructed as auto transformers these isolation transformers can also be used to change 110V to 220V or the reverse. We do not believe that 100 watt 110V isolation transformers have ever before been offered at less than double the price. **PUSH-TO-TALK MIKE** with switch on handle—98c. **LAPLÉ MIKES**—Specify whether carbon or magnetite 93c.

**BUFFALO RADIO SUPPLY 219-221 Genesee St., Dept. RT, BUFFALO, N. Y.**

# RADIO SCHOOL DIRECTORY



Become an **ELECTRICAL ENGINEER**

**MAJOR IN ELECTRONICS**



### B. S. DEGREE... IN 36 MONTHS

Make one of the most important decisions of your life—today! Capitalize on your electronic interests—decide to become an *Electrical Engineer*. Choose, also, to save a valuable year by earning your Bachelor of Science Degree here in 36 months of intensive year-round study.

This 46-year-old, non-profit Technical Institute offers a world-famous course in Electrical Engineering with a major in Electronics. You follow an industry-guided program which is constantly attuned to current developments. It presents a solid background in the basic sciences . . . Chemistry, Physics, Mathematics, Economics and Electrical Engineering subjects . . . plus 19 technical specialty courses in Engineering Electronics, including four courses in Electronic Design.

Practical, military or academic training will be evaluated for advanced credit.

#### ELECTRONIC TECHNICIAN

At the end of the first year of study of the Electrical Engineering course, the student is qualified as an Electronic Technician.

#### RADIO-TELEVISION TECHNICIAN

To young men interested specifically in radio and television: Prepare here for a career in television—the field which business leaders predict will be among America's top ten industries by 1951. In 18 months you become a Radio-Television Technician, ready for positions in receiver and transmitting testing, servicing, sales, supervision and production.

Because of this school's *concentric curriculum*, the Bachelor of Science degree in Electrical Engineering (Electronics major) may be earned in 24 additional months.

A SPECIAL PREPARATORY PROGRAM is offered for men lacking high school diplomas.

TRAIN in modern, well-equipped laboratories, shops and classrooms. Faculty of 85 specialists—over 1500 students and 30,000 graduates.



FALL TERM OPENS OCT. 3

## MILWAUKEE SCHOOL of ENGINEERING

Founded 1903 by Oscar Werwath

- Electrical Engineering . . . . . 36 months  
Electronics Major
- Electronic Technician . . . . . 12 months
- Radio-Television Technician . . . . . 18 months

Send Coupon for free 48-page Pictorial Bulletin "Your Career" and 110-page Catalog.



#### MILWAUKEE SCHOOL OF ENGINEERING

Dept. RE-949, N. Broadway and E. State, Milwaukee, Wis.

Without obligation send me the Bulletin, "Your Career," and your catalog. I am interested in \_\_\_\_\_ course.

NAME \_\_\_\_\_ AGE \_\_\_\_\_

ADDRESS \_\_\_\_\_

CITY \_\_\_\_\_ STATE \_\_\_\_\_ ( ) Veteran of World War II

## Make Your Career RADIO and TV

In no other industry does the future hold brighter financial promise and security than in AM and FM Radio, Television. These fields need and want men trained as announcers, script writers, disc jockeys, and radio technicians. It will pay you to investigate the Don Martin School of Radio Arts, established in 1937. Complete day and night classes . . . the latest equipment . . . and a staff of 30 nationally known instructors. Over 97% of the combination men graduates are placed on jobs immediately through the free placement service. Approved for veterans.

FREE—Write for Free Booklet "Your Future In Radio"

### Don Martin School of Radio Arts

1655 No. Chrookee, Hollywood, Calif. HUdson 23281



## RADIO COURSES

Preparatory Mathematics, Service, Broadcast, Television, Marine Operating, Aeronautical, Frequency Modulation, Radar.

Classes now forming for the fall term Oct. 1st  
Entrance exam, Sept. 19th

**Veterans. Literature.**

**COMMERCIAL RADIO INSTITUTE**  
(Founded 1920)  
38 West Biddle Street, Baltimore 1, Md.

# JOBS in TELEVISION



TELEVISION TECHNICIANS NEEDED AT ONCE

QUALIFIED MEN ONLY • GOOD PA • STEADY WORK • GOOD FUTURE

AMERICAN RADIO INSTITUTE

CAN TRAIN YOU FOR THIS JOB

Syracuse, N. Y. 131 Shonnard St.  
New York 2010 B'way (68th St.)  
Buffalo, N. Y. 640 Main St.  
Mount Vernon, N. Y. 174 Gramatan Ave.  
Free Employment Service—GI Approved

## TELEVISION NEW, INTERESTING TECHNICAL CAREER

As Television gains momentum rapidly, constantly, it offers to properly-trained technicians careers with a future in Industry, Broadcasting or own Business.

**Train at an Institute that pioneered in TELEVISION TRAINING since 1938.**

Morning, Afternoon or Evening Sessions in laboratory and theoretical instruction, under guidance of experts, covering all phases of Radio, Frequency Modulation, Television. Licensed by N. Y. State, Free Placement Service. Approved for Veterans.

**ENROLL NOW FOR NEW CLASSES**  
Visit, Write or Phone

## RADIO-TELEVISION INSTITUTE

480 Lexington Ave., N. Y. 17 (46th St.)  
Plaza 3-4585 2 blocks from Grand Central

## LEARN RADIO!

**PREPARE FOR A GOOD JOB!**  
COMMERCIAL OPERATOR (CODE)  
RADIO SERVICEMAN

**TELEVISION SERVICING  
BROADCAST ENGINEER**

V.A. Furnishes Books and Tools  
SEND FOR FREE LITERATURE

**BALTIMORE TECHNICAL INSTITUTE**  
1425 Eutaw Place, Dept. C, Baltimore 17, Md.

### FILL THAT JOB WITH A C.T.I. TRAINED MAN!

Solve your man-power shortage by employing well-trained, dependable young men who have been trained by Commercial Trades Institute. Our graduates have completed an intensive course in Radio or Television Servicing. Their training has been practical—in well-equipped shops under expert supervision. They've learned to do competent work. To enable you to evaluate the efficiency of C.T.I. training, we'll be glad to send you an outline of the course. You'll find the subject matter extensive, complete, thorough.

We probably have men who hail from your vicinity, but most of our graduates will travel anywhere for a good opportunity. We cordially invite employers to write us for detailed information on available men. (No employment fees.) Address:

Placement Manager, Dept. P108-8  
**COMMERCIAL TRADES INSTITUTE**  
1400 W. Greenleaf Ave., Chicago 26, Ill.



**RADIO ENGINEERING**  
**FM—Television—Broadcast**  
 Police Radio, Marine Radio, Radio Servicing, Aviation Radio and Ultra High mobile applications. Thorough training in all branches of Radio and Electronics. Modern laboratories and equipment. Old established school. Ample housing facilities. 7 acre campus. Small classes, enrollments limited. Our graduates are in demand. Write for catalog.  
**Approved for Veterans**  
**VALPARAISO TECHNICAL INSTITUTE**  
 Dept. C VALPARAISO, INDIANA

**AUDIO ENGINEERING SCHOOL**  
 A practical Audio Engineering course in Sound Fundamentals; DISC, FILM and MAGNETIC Recording; Transmission Measurements, Monitoring and Mixing; Laboratories contain Transmission Sets, Oscillators; Harmonic Analyzer, Distortion Sets, Intermodulation Analyzer, and other equipment. Recording Studio assimilating Broadcast, Motion Picture and Commercial Sound Recording. H. M. Tremaine, Pres.-Director. Approved for Veterans and Foreign Visas.  
**HOLLYWOOD SOUND INSTITUTE, Inc.**  
 1040-E North Kenmore Hollywood 27, Calif

**SHORT CUT** **CODESPEED**  
**Be an Expert**  
 Learn to be a Telegraph or Radio Operator. Thousands of men needed. Unusually interesting work. Learn to operate in wireless work. Packets, signals, Morse. With the famous call code. Special system. Quality for amateur or commercial license. Book of particulars free.  
**FREE BOOK**  
 Candler System Co.  
 Dept. 3-K, Box 928 Denver 1, Colo.

**RADIO ENGINEERING I**  
**DEGREE IN 27 MONTHS**  
 Complete Radio Engineering Course. Bachelor of Science Degree. Courses also in Civil, Electrical, Mechanical, Chemical, Aeronautical Engineering; Business Administration, Accounting, Secretarial Science. Graduates successful. 66th year. Enter Sept., Jan., March, June. Visitors welcome. See beautiful campus, well equipped laboratories. Write for catalog.  
**TRI-STATE COLLEGE** 2499 College Ave., ANGOLA INDIANA

**RADIO-TELEVISION**  
 Save school time and money with WRTI Specialized Training. Quality for high-income technical careers in only 6 months under practical engineer instructors. Practical daily lecture-laboratory training provides the skills necessary to hold down responsible positions. Become an FCC-licensed commercial Radio Operator; or an FM Radio-Television Technician. WRTI graduates employed world wide. **Approved for veterans;** non-veterans accepted. Send for free illustrated booklet.  
**WESTERN RADIO-TELEVISION INSTITUTE**  
 341-B West 18th St., Los Angeles 15, California

**ELECTRICAL TRAINING**  
 Intensive 32 weeks' residence course in fundamentals of industrial electrical engineering, including radio, electronics. Prepares for technician, engineering aides. Approved for veteran training. 57th year. Enter Sept. 6, Mar. 6. Catalog.  
**BLISS ELECTRICAL SCHOOL**  
 7549 TAKOMA AVENUE WASHINGTON 12, D. C.

**RADIO COURSES**  
 • RADIO OPERATING • CODE  
 • RADIO SERVICING • ELECTRONICS  
 • F. M. TELEVISION  
 • REFRIGERATION SERVICING  
 Write for Catalog TE and Picture Brochure  
**Y.M.C.A. TRAU & TECHNICAL SCHOOLS**  
 229 W. 66 St. (West of B'way) New York City

**NEW MAGNETIC RECORDING TAPE SPLICER**  
 The new Carson Tape Splicer: 1. Holds tape in correct alignment; 2. Makes a diagonal splice for no playback splice noise; 3. Uses any kind of cutting edge such as a razor blade for all cutting operations; 4. Allows all operations to be made with the tape in one position; 5. Uses any kind of cellulose adhesive tape; 6. Is small enough to be mounted on your recorder ready for instant use; 7. Permits anyone to easily and quickly make good splices on paper or plastic tape.  
 Carson Tap Splicer.....\$1.50  
 Splicer with blades and splicing tape.....\$2.00  
 Satisfaction guaranteed. Postpaid in U.S.  
**MAGNECESSORIES, Box 6963, Washington 20, D. C.**

**PROSPECTORS' GUIDE FOR URANIUM AND THORIUM MINERALS IN CANADA.** Published by the Bureau of Mines, Department of Mines and Resources, Ottawa, Canada. 4 1/2 x 6 1/2 inches. 37 pages.

Apparently the first of the recent crop of books and brochures on uranium prospecting, this book contains in brief and extremely clearly written form a description of uranium and thorium minerals and their modes of occurrence, with special attention to Canadian conditions.

Methods of detecting uranium-bearing minerals are described, with a complete appendix devoted to the Geiger counter, its use and care, precautions in using it, and servicing methods. Information and regulations useful to the prospector in Canada are also included in the book.

**ELECTRON TUBES—VOLS. I and II.** Edited by Alfred N. Goldsmith, Arthur F. Van Dyck, Robert S. Burnap, Edward T. Dickey and George M. K. Baker. Published by RCA Review, Radio Corporation of America, Princeton, N. J. 6 x 9 inches; Vol. I, 475 pages; Vol. II, 454 pages. Price \$2.50 per volume.

Ninth and tenth in the RCA Technical Book Series, these two volumes include all the more important papers published since 1935 by RCA research workers on the subject of electron tubes. Volume I covers the period from 1935 to 1949; Volume II contains papers published between 1942 and 1948.

The papers are grouped under four heads: general, transmitting, receiving and special. Some of them appear in full; others in summary form. This makes possible the inclusion in the two volumes of a larger number of papers than would have been possible had all been printed in full.

A very complete bibliography of periodical literature on vacuum tubes is included, as well as a listing of the RCA Tube Department's Application Notes published from 1932 to the present date.

**PHOTOFACT TELEVISION COURSE,** based on a series of lectures by Albert C. W. Saunders, and edited by B. V. K. French. Published by Howard W. Sams & Co., Indianapolis, Indiana. 8 1/2 x 11 inches. 215 pages. Price \$3.00.

Exhibiting the characteristics of its lecture-type composition, this course often goes into greater detail than similar books, almost as if the author had been stopped and queried by his reader. As a result, certain points of information which he could not find in parallel works have been discovered in it by this reviewer.

The language is marred to some extent by a scholastic style, apparently also due to the lecture background. On the other side of the ledger, the same background no doubt accounts for the many reviews, summations and consolidations of information presented, a feature which the solitary student will certainly find valuable.

Besides a rather complete index, the book contains a glossary of television terms as well as an extensive bibliography.

**NEW! INSTRUMENT KITS**

**5" OSCILLOSCOPE & STETHOSCOPE FOR TELEVISION, FM & AM**  
 High quality laboratory 5" oscilloscope plus stethoscope; 2 instruments for price of one. Designed for TV and FM alignment and AM servicing. Has jack for phone or screen meter. Permits signal tracing in any circuit through phones. These extra features in addition to conventional scope use built-in high gain 0.5 V probe amplifiers w/ response to 300 K. Complete with all tubes including 5" CR tube. Price, probe and headphones. Steel case. 15 1/2" x 7 1/2".  
**TS-7PK, Probe Kit \$4.00**  
**TS-7, factory built \$9.00**  
**TS-7P, factory built \$25**

**TS-1K, Beginners' Sig. Tracer Kit, \$6.75**  
 Fact. built..... 9.85

**TS-5K, Pocket Sig. Tracer Kit \$2.00**  
 Fact. built..... 28.95

**TS-6CK, Crystal (1N34) Probe Kit \$5.00**  
 Fact. built..... 7.50

**FEILER ENGINEERING CO., Dept. 9RC9**  
 945 George Street, Chicago 14, Ill.

Please send me the following instrument; Model.....  
 NAME.....  
 ADDRESS.....

**TELEVISION RECEIVER—\$1.00**  
 Complete instructions for building your own television receiver. 16 pages—11"x17" of pictures, pictorial diagrams, clarified schematics, 17"x22" complete schematic diagram & chassis layout. Also booklet of alignment instructions, voltage & resistance tables and trouble shooting hints.—All for \$1.00.  
**CERTIFIED TELEVISION LABORATORIES**  
 Dept. C, 5507-13th Ave., Brooklyn 19, N. Y.

**LEARN Electricity OR Radio-Television**  
**COYNE**  
**50th ANNIVERSARY**  
**IN THE GREAT SHOPS OF COYNE**  
**TRAIN QUICKLY! OLDEST, BEST EQUIPPED SCHOOL of ITS KIND in U.S.**  
**2 Opportunity Fields**  
 Come to the Great Shops of COYNE in Chicago during our 50th Anniversary Year! Get quick, practical training in RADIO-TELEVISION or ELECTRICITY. G. I. Approved. Finance plan for non-veterans. Mail Coupon Today for complete details.  
**NOT "HOME-STUDY" COURSES!**  
 You learn on real, full-size equipment, not by mail. Finest staff of trained instructors to help you get ready quickly for a better job, a fine future.  
**FREE BOOKS** Clip coupon for big illustrated Coyne book on either ELECTRICITY or RADIO-TELEVISION. Both books sent FREE if you wish. No obligation; no salesman will call. Act NOW!  
**B. W. COOKE, Pres.**  
**COYNE Electrical & Radio School, Dept. 69-81H**  
 500 S. Paulina Street, Chicago 12, Illinois  
 Send FREE BOOK and full details on:  
 ELECTRICITY  RADIO-TELEVISION  
 NAME.....  
 ADDRESS.....  
 CITY..... STATE.....

**WHERE RADIOMEN MEET, EAT and SLEEP**

Visit the  
**FAMOUS  
FIESTA  
LOUNGE**  
Renowned for  
Fine Food

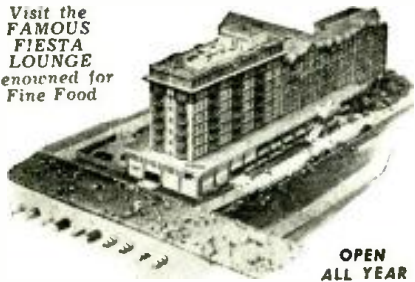

**HOTEL STRAND**

Atlantic City's Hotel of Distinction

The Ideal Hotel for Rest and Relaxation • Beautiful Rooms • Salt Water Baths • Glass enclosed Sun Porches • Open Sun Decks atop • Delightful Cuisine • Garage on premises. • Moderate Rate Schedule.

Exclusive Pennsylvania Ave. and Boardwalk

OPEN ALL YEAR

**Check these Prices!**



**SELENIUM RECTIFIERS**  
115 VOLTS

For Radio & Television Application.

fully guaranteed	lots of 10, each	lots of 100, each
75 MA	56	50
100 MA	64	50
150 MA	72	64
200 MA	89	78
250 MA	1.16	.88

**OPAD-GREEN COMPANY**

71 Warren St., N. Y. 7, N. Y. E Eekman 3-7385-6

**GEIGER COUNTERS**

HAMS! BE FIRST AGAIN! BUILD YOUR OWN!

Find radium, trace water mains, prospect, check local contamination, assay ores.

- Send AEC booklet "Prospecting for Uranium" \$5.00
- Send Calibrated Uranium standard; Assay \$7.50
- Send 30mg cm<sup>2</sup> Al wall Beta-Gamma tube \$7.50
- Send complete parts kit and diagram \$48.50
- Send assembled 5.5 pound portable \$90.00
- Send 110VAC quantitative lab. model \$150.00
- Send detailed information  check  COD

**COSMIC COUNTERS**

112 Cornell Ave. Swarthmore, Pa.

**HEADQUARTERS FOR ELECTRONIC TUBES IN ALL QUANTITIES**



5000 Magnetrons, 1000 Kylstrons  
500,000 other tubes. Write for our Bulletin and Prices.

**LIBERTY ELECTRONICS, INC.**

135 LIBERTY STREET NEW YORK 6, N. Y.  
PHONE WOrth 4-8262

**PEN-OSCIL-LITE**

Extremely convenient test oscillator for all radio servicing; alignment • Small as a pen • Self powered • Range from 700 cycles audio to over 600 megacycles u.h.f. • Output from zero to 125 v. • Low in cost • Used by Signal Corps • Write for information.

**GENERAL TEST EQUIPMENT**  
38 Argyle Ave. Buffalo 9, N. Y.

**\$1,000 A MONTH**



That's what **JUST ONE** of the many plans in this book brought in—over \$1,000 a month, steadily, from radio service alone. **HOW TO MAKE MORE MONEY IN RADIO SERVICE** is so full of money-making plans and ideas it will amaze you. Why work for wages? Why not become your own boss and make more money? **EVEN BEGINNERS** who used some of the easier plans in this book averaged **WAY OVER \$100 A WEEK** just working from home. This book is making money for servicemen and beginners, everywhere—U.S.A., Canada, America, Hawaii, Philippines, and other countries. Letters of thanks are continually coming in.

**AT LAST!**

The real money-making secrets of radio service are given out in this book.

- Book very helpful—following advice in the book earned high as \$100 a week radio repairing, in my apartment. **C. C. Seidler, Brooklyn, N. Y.**
- In business 10 years—received many valuable pointers—read it 3 times. Would not take twice the price for it. **W. J. Phillips, Shelington, W. Va.**
- In radio 15 years—Book contains far more information than expected—Every radioman should have this book. **W. J. Fraser, Elmont, N. Y.**
- Best of its kind that have ever been printed. **W. Bradford, E. Chicago, Indiana**
- Have book only a week—couldn't stop reading it. Already made money and many new customers. **A. T. Waters, Jr., Carthage, N. Y.**
- In business 17 years. Book contains many things which could save me many years to learn the hard way. Book worth many times its small cost. **P. V. Fuzner, Elmwood, Illinois**

25 years experience are packed in this 83 page book. 8 1/2 x 10 1/2, by V. Gale, for servicemen, beginners, students. Among **MANY OTHER THINGS** it shows you where the money is and how to get it **FAST**; How to get plenty of customers; How to test sets without taking them out of cabinets and give estimates **QUICKLY**; How to operate spare time and build to full time; How much to charge; How to connect with certain **BIG MONEY** concerns; How to increase business and expand. Send for this book today and start making more money almost as soon as you get it. The full price is only \$3 (any convenient form) postpaid; or C.O.D., at \$3 plus a few cents postal charges. You have nothing to lose. Examine it for 5 days. If you aren't positively delighted return it and we will refund your \$3 promptly. If you want more information about the book send for literature #2-1E. It's free.

**MERIT PRODUCTS, DEPT. RE.**

216-32 132 Avenue. Springfield Gardens 13, N. Y.

If you don't receive our **FREE BARGAIN BULLETINS** you're losing money!

**A RADIONIC SPECIAL!**

Stacked, All Band Conical TV Array... at Lowest Cost

It's here! Scientifically designed, precision made, all-band conical TV array—giving tremendous gain and absolute minimum interference at a cost no greater than the usual dipole. Permits direct coupling to 72, 130 or 300 ohm line with minimum loss. All dual construction, 10 foot mast included. Amazingly low price of only **\$11.95**

In lots of 3, \$11.45 each  
Best quality 300 ohm twin-lead, 100 feet. \$1.30, 1000 feet \$12.25.  
Not to be used with order. Balance C.O.D.

**RADIONIC EQUIPMENT COMPANY**

Tribune Theater Entrance  
170T Nassau Street New York 7, N. Y.  
WOrth 2-0421 :: Open daily 9 to 6--Saturday 9-5

**FREE! MAIL TODAY!**  
GET YOUR COPY AT ONCE!  
OF RADIONIC'S Bargain Catalog, Radio & Television Sets—Parts—Accessories, Unbeatable Values!

RADIONIC EQUIPMENT CO., Dept. 109  
170T Nassau Street, New York 7, N. Y.

Please rush Free Copy of your latest Bargain Catalog of Radio and Television Sets, Parts, Tubes and Accessories.

NAME \_\_\_\_\_  
ADDRESS \_\_\_\_\_  
CITY \_\_\_\_\_ STATE \_\_\_\_\_

Allied Radio Corporation	47
American Phenolic Corporation	63
Amplifier Corporation of America	62
Art Radio	71
Bell Telephone Laboratories, Inc.	51
Boland & Boyce, Inc.	8
Brooks Radio Distributing Company	65
Buffalo Radio Supply	77
Capitol Radio Engineering Institute	7
Cargille	81
J. Cartwright & Son	81
Certified Television Laboratories	79
Cinex, Inc.	72
Cleveland Institute of Radio	18
Communications Equipment Company	61
Consolidated Publications	65
Cosmic Counters	83
Coyne Electrical School	79
DeForest's Training, Inc.	11
Electronic Instruments Corp.	67
Electronic Measurements Company	76
Electro Products Laboratories	74
Electro-Voice Manufacturing Company	57
Fair Radio Sales	74
Faier Engineering Company	79
Fisher Research Laboratory, Inc.	72
General Electronic Distributing Company	49, 73
General Test Equipment Company	80
Hallmark Electronic Corporation	81
Heath Company	13, 14, 15, 16, 17
Hershel Radio Co.	6
Hickok Electrical Instrument Company	72, 75
James Oliver Hagg, Jr.	71
Instructograph Company	81
International Resistance Company	75
Manuel Klein	72
Lafayette-Concord Co.	55
Leotone Radio Corporation	66
Liberty Electronics	80
McGee Radio Company	59
McGraw Hill Co.	76
Mag necessities	79
Merit Products	80
Mid-America Company	70
Midwest Radio Corporation	67
Murray Hill Books, Inc.	67, 77
National Company	Back Cover
National Radio Institute	3
National Schools	5
Nescorp Electronics	69
Niagara Radio Supply	68
Ohmite Manufacturing Company	4
Opad-Green Company	80
Opportunity Adlets	68
Precision Apparatus Company	71
Precision Radiation Instrument, Inc.	76
Progressive Electronics Company	81

**RADIO SCHOOL DIRECTORY**

(Pages 78-79)

American Radio Institute  
Baltimore Technical Institute  
Bliss Electrical School  
Candler System Company  
Commercial Radio Institute  
Commercial Trades Institute  
Dan Martin School of Radio Arts  
Hollywood Sound Institute  
Milwaukee School of Engineering  
New York YMCA School  
Radio-Television Institute  
Tri-State College  
Valparaiso Technical Institute  
Western Radio-Television Institute

Radiac Company	62
Radio City Products Company, Inc.	66
Radio Corporation of America	Inside Front Cover
Radio Dealer's Supply Co.	48
Radiomic Equipment Company	80
Radio Supply & Engineering Company	65
Senco Radio, Inc.	68
Shure Brothers, Inc.	53
Simpson Electric Company	58
Sprague Products Company	65
Sprayberry Academy of Radio	Inside Back Cover
Hotel Strand	80
Superior Instruments Co.	76
Sylvania Electric Products	12
Telekit	56
Telrex, Inc.	10
Transvision	60
United Surplus Materials	64
Universal General Corporation	74
Warner Electric Company	72
Weller Manufacturing Co.	9
Wells Sales, Inc.	82
Wholesale Radio Parts Company, Inc.	70



# CARTWRIGHT'S

## TRU-CUT TIN SNIPS

Patented  
Easiest cutting tin snip. Handy tool for 1,001 jobs! Lightweight—will cut 18 gauge sheet metal. Very finest for cutting metal accurately to any simple or complex pattern.



Prompt Delivery

\$4.95 ea.

Post. paid on cash orders

### Check These 7 Tru-Cut Features

1. Cuts a perfect circle, right or left. 2. Cuts square points, both ways, right or left. 3. Hands are always above material when cutting. 4. TRU-CUT Snips are patented and protected by Cartwright & Son. In business since 1885. 5. Tool is guaranteed against mechanical defects and will be replaced upon returning to factory. 6. Special "Tension Washer" designed and made for TRU-CUT retains a right fit. 7. Faster cutting. Truer cutting. Easier cutting. Less filing. Stay Sharp Longer and will give Years of Service. Get this easy time saving snip today. If dealer can't supply order direct from us. Send cash, check or money order, and we'll pay postage. **S.A.T.S.E.A.T.T.I.O.N. GUARANTEED \$1.00 deposit on C.O.D.'s.** We're for FREE CATALOG of complete line of pruning shears, hand held wire shears.



1. TRU-CUT cuts a perfect circle, right or left.
2. TRU-CUT cuts square points, both ways, right or left.
3. TRU-CUT cuts a straight line, both ways, right or left.

**J. CARTWRIGHT & SON**  
Dept. 9R-E  
Malaga California

### "ALL-SEE" TRANSPARENT BOXES!

Safe and Loss-Proof Containers for  
• Screws • nuts • Small Parts •  
Mind those small parts—search to find and lose hard to replace with a set of these "All-See" Plastic transparent containers and covers. Assure easy and safe storage. Pay for themselves.  
Each set contains one box, 1 7/8" sq.; five boxes, 1 7/8" x 1 1/2", four boxes, 1 7/16" sq. 10 boxes in all  
Transparent case. Order a set for yourself and a set for that thinking pal of yours.  
An inexpensive and unusual gift. No C.O.D.'s, please. Remit \$1 for each order complete set 16 for \$75. Or send for FREE leather kit.  
**\$1.00**

**CARGILLE, Dept. RC, 116 Liberty St. New York, N. Y.**

# EASY TO LEARN CODE

It is easy to learn or increase speed with an Instructograph Code Teacher. Affords the quickest and most practical method yet developed. For beginners or advanced students. Available tapes from beginner's alphabet to typical messages on all subjects. Speed range 5 to 40 WPM. Always ready on QRM.  
**ENDORSED BY THOUSANDS!**  
The Instructograph Code Teacher live ally takes the place of an operator instructor and enables anyone to learn and master code without further assistance. Thousands of successful operators have acquired the code with the Instructograph System. Write today for complete detail and purchase plans.

**INSTRUCTOGRAPH COMPANY**  
4701 Sheridan Rd., Dept. RC, Chicago 40, Ill.

**>> TUBES <<**

FACTORY SEALED CARTONS  
ANY ASSORTMENT—25 for \$9.95  
50 FOR \$18.00 100 FOR \$35.00

1A7GT 6AG5	12A7T 25L6
1H5GT 6AK5	12AU7 25Z6
1R5 6AL5	12AX7 35B5
1S5 6AU6	12BA6 35L6
1T4 6BD6G	12BE6 35T4
1U4 6FR6	12CA7GT 375GT
3A4 6J6	12S7GT 50B5
3Q4 6N7GT	12SK7GT 50L6GT
3S4 6T8	12SQ7GT 53
3V4 12AT6	19T8 11Z73

39c Each

Include sufficient postage; excess refunded with order. C.O.D. with 25% deposit.  
Many other tube types available. Send for free list. Complete stock available of TV replacement parts.

**HALLMARK ELECTRONIC CORPORATION**  
594 Communipaw Ave. Bergen 4-2087  
Jersey City 4, New Jersey " 4-6365

**PROSPECTING FOR URANIUM.** Published by the United States Atomic Energy Commission and the United States Geological Survey, through the Government Printing Office, Washington, D.C. 4 1/2 x 5 1/2 inches, 123 pages. Price 30 cents.

This little book contains very complete tables of uranium-bearing minerals, descriptions of their deposits, and methods of search for them. The Geiger counter and its operation are completely described.

Other subjects covered are laboratory assays and selling procedure, laws and regulations, and prices and special awards. Government circulars 1 to 5 on the latter subject are printed in an appendix. Other appendices include a list of books and pamphlets, maps, and libraries which supply information interesting to the uranium prospector; manufacturers and distributors of prospecting equipment; the licensing regulations of the Atomic Energy Commission; information in regard to mining claims, and other special information of interest.

**YOU CAN FIND URANIUM.** by Joseph L. Weiss and William R. Orlandi. Published by J. B. Weiland & Co., San Francisco. 6 x 8 1/2 inches. 128 pages. Price \$2.75.

A short historical introduction to the subject is followed by a description of uranium and thorium minerals, illustrated by a number of photos. The various types of prospecting devices, including Geiger counters, spinthariscopes, radiosopes, electroscopes, and fluorescent lamps, are described with their uses and disadvantages. A complete chapter on the Geiger counter is added to the shorter description in which it takes its place among other prospecting devices.

There are also chapters on staking a claim, areas in which prospecting is possible, and the government price and bonus program.

**ADVANCES IN ELECTRONICS,** edited by L. Marton. Published by Academic Press, Inc., New York. 6 1/4 x 9 1/4 inches, 475 pages. Price \$9.

This is Volume I of what is intended to be a yearly publication recording progress in electronics research and development.

The following ten articles are included: Oxide Coated Cathodes, by Albert S. Eisenstein (Univ. of Mo.); Secondary Electron Emission, by Kenneth G. McKay (Bell Labs.); Television Pickup Tubes and the Problem of Vision, by A. Rose (RCA Labs.); The Deflection of Beams of Charged Particles, by R. G. E. Hutter (Sylvania); Modern Mass Spectroscopy, by Mark G. Inghram (Argonne National Lab.); Particle Accelerators, by M. Stanley Livingston (Brookhaven National Lab.); Ionospheric Research, by A. G. McNish (National Bureau of Standards); Cosmic Radio Noise, by Jack W. Herbstreit (National Bureau of Standards); Propagation in the FM Broadcast Band, by Kenneth A. Norton (National Bureau of Standards); and Electronic Aids to Navigation, by J. A. Pierce (Harvard Univ.).

# PROGRESSIVE KITS

The best quality—the largest variety...  
For Beginner, Technician or Engineer  
**FREE Gift with Each Kit**  
plus **FREE MEMBERSHIP**  
in **PROGRESSIVE Radio & Television Club**;  
Provides **FREE Consultation Service.**

**NOW! BUILD 15 RADIOS \$14.75**  
COMPLETE KIT ONLY.

**EXCELLENT FOR BACKGROUND IN TELEVISION**

Contains everything you need, instruction on book, metal chassis, etc. Includes: receivers and other necessary radio parts. The Instruction Book written by experts & also instructors and engineers teaches you to build radio in a professional manner. The circuits are designed to provide excellent performance.  
Each of the 15 radios you will build operates on 110-120 volts AC or DC. The **PROGRESSIVE Radio Kit** is excellent for learning the principles of Receiver, Transmitter and Amplifier design. It is used in many Radio Schools and colleges in U.S.A. and abroad. It is used by the Veterans Administration for veteran training.  
**FREE: ELECTRICAL AND RADIO TESTER** plus **FREE Membership** in the Progressive Radio & Television Club. You will be entitled to **FREE** expert advice and consultation service with licensed radio technicians.  
**ORDER YOUR KIT NOW!**

- 7"-10" TELEVISION KITS**  
Factory built and aligned 13 channel Tuner—18 Tubes Kit  
7" Kit..... **\$59.50**  
Complete set of tubes, including Cathode Ray Tube **\$41.58**
- Factory built and aligned 13 channel Tuner, 10" Kit, less tubes **\$82.99**
- Complete set of tubes, including Ray Tube **\$55.80**
- Cabinet for 7" or 10" **\$24.50**

**5" OSCILLOSCOPE KIT AM-FM TELEVISION**  
An absolute "must" for today's radio-hobbyist. Includes: 1 set of 4 Model Tubes—2-817, 2-3Y3, 1-881 1-12BP1. **FREE** Book on Cathode Ray Oscilloscope. **\$39.95**

**VACUUM TUBE VOLTMETER KIT**  
A professional piece of test equipment for use for FM and TV. Attractive steel case. **FREE** Book on Advanced Servicing Techniques. **\$23.95**

**SIGNAL TRACER KIT**  
An invaluable aid in trouble-shooting Test Instruments. **\$21.95**

**Sweep Generator Kit**  
A necessity for television work. 5-Tube circuit, 5 MC to 220 MC Sweep width 0 to 10 MC. Variable biasing control. 110v. operation.  
**FREE** Television & FM Servicing Notes. **\$22.95**

**SIGNAL GENERATOR**  
AM & FM alignment and trouble shooting marker for sweep generator. 15kc to 3.1 MC on fundamentals. Over 100 MC on strong harmonics. 400 cycle audio. 110v. operation.  
**FREE** Test Instruments book in Italian. **\$18.95**

**TOOL KIT**  
Consists of bladed cutters, combination lock note files, and cutters, amber-hand screwdriver 77 Watt soldering iron, and supply of solder.  
**FREE** 35 Watt Midget soldering iron and supply of flux up wire. **\$5.75**

**OTHER KITS**  
2-Tube FM Receiver, Battery portable receiver, 3-043 Portable Receiver, 5-Tube Broadcast Band Superhetro Receiver, 5-Tube 2-band superhet receiver, multi-tube amplifier, signal tracer probe.  
**FURTHER INFORMATION ON REQUEST.**  
Product 25% off full payment accompanies order. C.O.D. orders accepted in U.S.A.  
**PROGRESSIVE ELECTRONICS CO.**  
497 Union Ave., Brooklyn 11, New York  
Dept. RE-29 Phone: EVergreen 8-0054

- TRANSMITTING
- RECEIVING
- INDUSTRIAL
- SPECIAL PURPOSE

# TUBES

*Guaranteed*  
by  
**WELLS**

**IMMEDIATE DELIVERY  
AT THE LOWEST PRICES  
IN OUR HISTORY!**

Check this list for exceptional values in magnetrons, cathode ray tubes, voltage regulators, transmitting tubes—also neon, pilot and flashlight bulbs. These are brand new, standard make tubes. Order enough for future needs directly from this ad or through your local parts jobber.

Type	Price	Type	Price	Type	Price	Type	Price			
O1A	\$0.45	10Y/VT-25	\$0.45	707B	\$23.25	872A	\$2.45			
1B22	4.35	12A6	.25	710A	2.15	874	2.15			
1N21 Xtal Diode	.65	12K8	.65	713A	1.55	878	2.15			
1N21B "	.80	125F7	.70	714AY	9.95	930	2.20			
1N23 "	.80	125H7	.40	RK715B	7.95	954	.50			
1N23A "	.85	125K7	.70	717A	.90	955	.55			
1N27 "	.85	125L7/GT	.40	721A	3.95	956	.55			
1R4/1294	.65	125R7	.70	724A	4.65	957	.55			
1R5	.95	12x825 2 amp. Tungar	2.25	724B	4.25	991 (NE-16)	.30			
1S5	.95	13-4 Ballast	.35	725A	19.95	1005	.35			
1S21	1.10	15R	1.40	726A	19.95	1148	.40			
1T4	.95	FG-17	2.85	730A	11.95	1201	.75			
2C26	.35	REL-21	3.25	801	.60	1616	1.25			
2C26A	.45	23D4 Ballast	.45	801A	.75	1619	.55			
2C34	.55	25Z6/GT	.55	803	6.95	1624	1.25			
2C34	.55	28D7	.40	804	9.95	1625	.45			
2J21A	11.45	30/VT-67 (For Walkie Talkies)	.75	805	5.45	1626	.45			
2J22	9.85	33/VT-33	.75	808	1.75	1629	.45			
2J26	8.45	RK-34	.45	809	2.75	1635	.95			
2J27	14.45	34	.35	810	7.95	2051	.95			
2J31	9.95	39/44	.35	811	2.35	7193	.35			
2J32	14.85	45 Spec.	.55	813	7.85	8011	2.55			
2J33	19.95	46	.80	814	3.75	8012	4.25			
2J37	13.85	EF50/VT250	.45	815	2.85	8020	3.35			
2J38	12.95	CEQ 72	1.50	826	.49	8025	7.50			
2J48	14.95	72/3B24	1.75	829	3.25	9001	.70			
2X2/879	.65	VR-75	.90	830B	3.95	9002	.45			
3A4	.35	76	.55	837	1.75	9003	.45			
3A5	1.05	VR-78	.65	838	3.25	9004	.45			
3AP1 CRT	3.85	80	.45	841	.55	9006	.45			
3B22	2.95	FG-81-A	3.95	843	.55					
3B24	1.75	83	.85	851	39.50	<b>NEON BULBS FOR RADIO USE</b>				
3BP1 CRT	3.75	83V	.95	WL-860	2.55	NE-2	\$0.06			
3CP1-51	1.95	89Y	.40	861	32.50	NE-15	.06			
3C24/24G	.47	VR-90	.70	864	.55	NE-16	.24			
3D6/1299	.65	VR-92	.65	865	2.55	NE-20	.06			
3FP7 CRT	2.95	100R	3.25	866A	1.30	NE-21	.24			
3HP7 CRT	3.75	FG-105	9.95	869	26.50	NE-48	.24			
3GP1 CRT	.90	VR-105	.85	869B	28.95	NE-51	.06			
3Q5	17.95	VU-111	.65							
REL-5	3.95	117Z3	.55							
5AP1 CRT	2.95	VT-127 English	.25							
5BP1 CRT	3.85	VT-127A	2.95							
5CP1 CRT	6.55	VR-150	.55							
5GP1 CRT	14.25	VT-158	9.85							
5J23	14.25	FG-172	29.50	<b>Pilot and Flashlight Bulbs</b>						
5J29	.40	205B	1.95	Stock No.	Mazda No.	Volts	Watts	Bulb	Base	Price
5Y3G	.90	211 (VT-4-C)	.65	350-40	64	6-8	3CP	G-6	DC Bay	\$0.07
6A6	.95	215A	1.95	350-31	57	12-16	1.5CP	G4 1/2	Min. Bay	.08
6A87	.90	231D	1.30	Spec.			6	S-6	Cand. Scr.	.13
6AC7	.80	282B	4.25	350-20	1446	12	.2 amp.	G-3 1/2	Min. Scr.	.07
6AK6	.95	304TM	5.95	350-14	49	2	.06	T-3 1/4	Min. Bay	.06
6B7	.65	304TL	1.75	350-15	356	120	3	S-6	Can. Bay	.11
6BE6	.45	307A	4.25	348-22	PR-10	6	.5 amp.	B3 1/2	Min. Flang	.05
6C4	.75	316A	.75	350-19	Proj. Bulb	120	500W	T-20	Med. Pf	1.45
6C6	19.75	350B	2.55	LB-17C		24	.035A	T-2	Tel. Base	.18
6C21	.60	371B	.85	LB-58A		110	7W	C-7	Cand. Scr.	.17
6D6	.70	388A	4.95	LB-57A	53	12-16V	1CP		Min. Bay	.07
6E5	.50	417A	19.95	LB-100A	Airplane Headlight	24V	239W	A-19	Med. Pf	.38
6M6	.70	434A	7.45	LB-101	323	3	(AIRCRAFT)	T-1 1/2	953	.22
6J5/GT	.90	446A	1.55	LB-101A	LM-60	115V	250W	T-20	Med. Pf	.40
6J6	.80	450TH	19.95	LB-102	1195	12-16	.50CP	RP-11	DC Bay	.14
6N7/GT	.80	GL-471A	2.75	LB-102A	CC-13	110V	100W	T-8	DC Pf	.33
6R7G	.80	527	11.25	LB-102B	1491	2.4	.8 amp.		DC Bay	.14
6SF5	.70	WL-530	17.50				(Airplane type)			
6SG7	.40	WL-531	17.50	LB-102C	3D2	28			DC Bay	.14
6SH7	.65	532A/1B32	3.55	LB-104	313	28	.17 amp.	T-3 1/2	Min. Bay	.11
6SJ7/GT	.65	GL-559	3.75	LB-105	1816	13V	.33A		Min. Bay	.12
6SK7/GT	.65	KU-610	7.45	LB-106	12	12	.09-.11	T-2	Min. Base	.17
6SL7/GT	.80	HY-615	1.20	LB-107	24-A2 WE	24	.75 .105	T-2	Tel. Base	.18
6SN7/GT	.60	700B	9.95	LB-108	S-14 Argon	105	2 1/2 Watt		Med. Scr.	.22
6SQ7/GT	.65	700C	9.95	LB-109	5	Telephone	Type Neon	T-2		
7A4	.65	700D	9.95	350-18	1477	24	17	T-3	Min. Scr.	.16
7A7	.40	702A	2.95							
7C4/1203	.65	703A	4.85							
7C7	.65	705A	2.65							
7E6	.75	707A	19.50							
7F7	.75									
7H7	.75									
7N7	.65									
7Q7	.40									
10/VT-25A										

**10% DISCOUNT ON ORDERS OF \$100. OR OVER**

Manufacturers: We carry thousands of electronic parts in stock. Send us your request for quotations.

Distributors: Our standard jobber arrangement applies. Order directly from this ad.

**WELLS**  
SALES, INC.

**320 N. LA SALLE ST., DEPT.-Y, CHICAGO 10, ILL.**



**YOU** Need My **PRACTICAL** Training to Make Money in

# TELEVISION- RADIO and ELECTRONICS!



*I'll Send You*  
**8 BIG KITS of**  
Radio Parts and Equipment . . .

Learn at  
**HOME**  
IN YOUR  
**SPARE TIME**

**NOW IS THE TIME To Get Into This Fast Growing Industry—Prepare For A Fine Paying Job Or Your Own Business!**

If you want to get into Radio-Television and Electronics . . . you owe it to yourself to get the facts about my training. I have trained hundreds of men to become outstanding service technicians—and I'm ready to do the same for you. Whether your goal is a fine paying job in one of Radio's many branches—or a successful Radio and Television business of your own—you need the kind of training I offer! My training is practical and down to earth. **YOU NEED NO PREVIOUS EXPERIENCE.** You'll be astonished at your rapid progress. I start you with basic fundamentals and give you plenty of practical shop-bench training with many kits of parts I send you. This is the training that sticks with you and makes money for you on the job!

## Get Paid For Spare Time While Learning

Soon after you start training I send you my famous **BUSINESS BUILDERS** that show you how to make money in spare time doing interesting Radio jobs. Look at the useful and valuable equipment you get while training with me (illustrated at left)—I send you these 8 big kits of Radio parts and equipment and help you build step-by-step a powerful 6-tube superhet radio, a 16-range test meter, plus other mighty useful equipment for Radio and Television servicing. You will perform over 175 fascinating experiments while training. You will learn about Television—so that you will be qualified to step into this fast growing, profitable field. I also send you many valuable service manuals, diagrams and my book telling exactly how to set up your own Television and Radio shop. *I want you to learn all about my training*—and that is why I urge you to clip and mail the coupon below for my two big **FREE** Radio books. I employ no salesmen—and nobody will call on you. The important thing is to act now and get the facts.

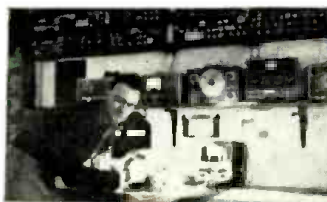
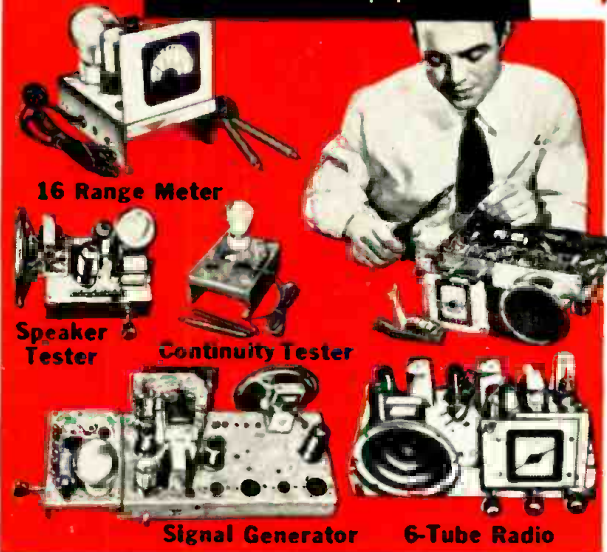

## HAVE A BUSINESS OF YOUR OWN

A profitable Radio and Television Service Shop may be started with little capital. I will show you how to get started and how to build your small business. At left is pictured one of my graduates, Mr. Merrit C. Sperry of Fairmont, Minnesota in his own shop. The way is also open for you to build a good **SERVICE BUSINESS FOR YOURSELF.**

## ALL KITS ARE YOURS TO KEEP

Each of the hundreds of Radio parts and other items I send my students is theirs "for keeps." You may use this equipment in your Radio and Television service work and save many dollars by not having to buy expensive "ready-made" test equipment. Each of my 8 kits will help you advance and learn important steps in Radio and Television servicing.



**CALVIN SKINNER** of New Orleans, La. tells us he makes \$5 to \$10 in spare time repairing radios. He is now also working with his own Television set.



**LOREN D. SAUCIER** of Coloma, Mich. reports that my training has made it possible for him to repair large numbers of Radio and Television receivers.

## RADIO AND TELEVISION INDUSTRY BOOMING

You couldn't pick a better time to get into Radio-Television and Electronics. New Television stations are going on the air to serve every major city—hundreds of new AM and FM Radio broadcasting stations are also on the air to serve practically every community in America. All this creates new and bigger opportunities for the trained man who knows Radio-Television and Electronics. Good Radio and Television service men are needed **NOW!**

## VETERANS

**THIS TRAINING AVAILABLE TO YOU UNDER THE G. I. BILL**

My Training Includes:  
**Radio Servicing**  
**Television**  
**FM Frequency Modulation**  
**Public Address and High Frequency Applications**

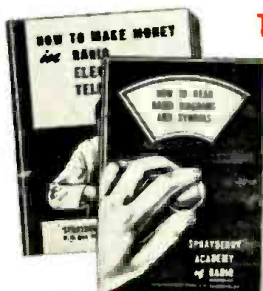

These Two Big Radio Books **FREE!**

Just mail coupon for a **FREE** sample Sprayberry Lesson and my big **FREE** book, "How To Make Money in Radio-Television and Electronics." Learn why my really practical training is best of all for you. Discover what's ahead for you in the fast moving Radio-Television and Electronics industry. No obligation. Don't delay—the future is too important to you. Mail the coupon now—and count on me for fast action.

## RUSH COUPON Today!

**SPRAYBERRY ACADEMY of RADIO, Dept. 20-A 111 North Canal St., Chicago 6, Ill.**

Please rush my **FREE** copies of "How To Make Money In Radio-Television and Electronics" and "How To Read Radio Diagrams and Symbols."

Name..... Age.....  
Address.....  
City..... State.....

**SPRAYBERRY ACADEMY OF RADIO**  
111 N. CANAL, DEPT. 20-A, CHICAGO 6, ILL.

( ) Check here if you are a Veteran.

presenting

the

**TV-12W**

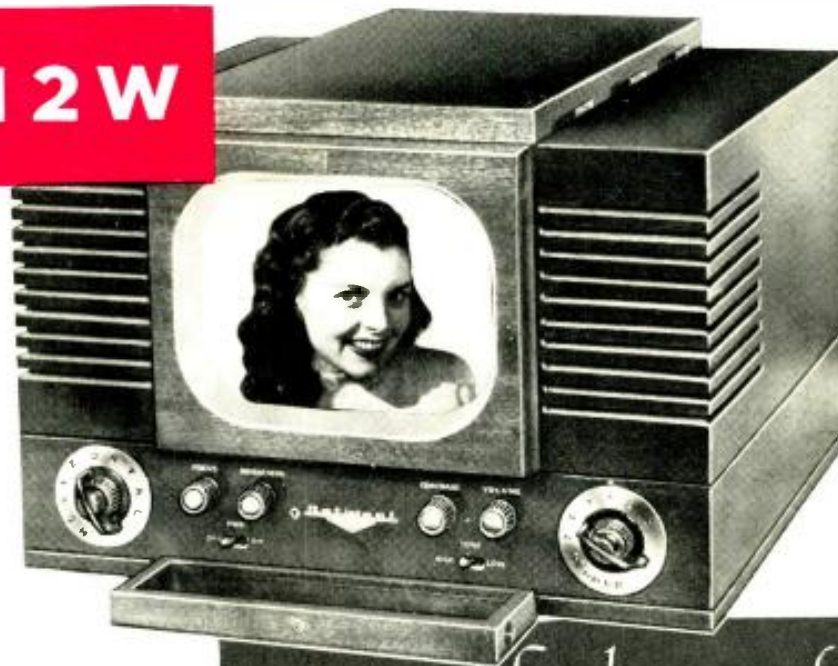

*newest and handsomest of all*

- Latest flyback high voltage supply gives clear, bright pictures even in fringe areas
- Automatic frequency control locks picture in place
- Two flanking speakers do justice to FM sound
- Front-of-panel focus control
- Coil switching assures equivalent of separate, high-Q tuned circuits for each channel
- Automatic gain control
- 3-stage 37 mc IF minimizes picture interference caused by other radio services
- Double-tuned RF bandpass circuits improve selectivity and image ratio.
- Automatic Station Selector and fine tuning control.



Features a big 12½-inch picture tube—most popular size of all—in a genuine mahogany cabinet handsomely styled in the spirit of tomorrow . . . yet only

**\$29950**

SLIGHTLY HIGHER WEST  
OF THE ROCKIES

